



QUICK SELECTION / Selezione veloce

input speed (n_1) = 1400 min⁻¹

Output Speed n_2 [min ⁻¹]	Ratio i	Motor power P_{1M} [kW]	Output torque M_{2M} [Nm]	Service factor f.s.	Nominal power P_{1R} [kW]	Nominal torque M_{2R} [Nm]	Available B5 motor flanges					Available B14 motor flanges				Output Shaft \varnothing	Ratios code	
							-C	-D	-E	-F	-G	-R	-T	-U	-V			
							71	80	90	100 112	132	80	90	100 112	132			
32.5	43.03	5.5	1478	1.1	5.8	1600	B									201313	standard $\varnothing 50$ $\varnothing 60$ On request	01
28.9	48.52	5.5	1667	0.9	5.0	1550	B									161315		02
27.0	51.81	4	1302	1.2	4.8	1600	B									201311		03
24.1	58.17	4	1462	1.1	4.3	1600	B									161313		04
22.2	63.09	4	1585	1.0	3.8	1550	B									131315		05
20.0	70.05	4	1760	1.0	4.0	1800	B									161311		06
18.5	75.65	4	1901	0.9	3.7	1800	B									131313		07
15.4	91.09	3	1723	1.0	3.1	1800	B									131311		08
12.6	111.50	2.2	1553	1.2	2.5	1800	B									111311		09
10.5	133.91	2.2	1865	1.0	2.1	1800	B									81313		10
8.7	161.24	1.5	1548	1.2	1.7	1800	B									81311		11
7.6	184.40	1.1	1293	1.1	1.2	1450	B									61313		12
6.3	222.04	1.1	1557	1.1	1.2	1750	B									61311		13

The dynamic efficiency is **0.94** for all ratios

Motor Flanges Available
Flange Motore Disponibili

B) Supplied with Reduction Bushing
Fornito con Bussola di Riduzione

B) Available on Request without reduction bushing
Disponibile a Richiesta senza Bussola di Riduzione

C) Motor Flange Holes Position
Posizione Fori Flangia Motore

5

EN Unit **853C** is supplied without lubricant and equipped with a breather, level and drain plugs. User can add mineral oil keeping existing plugs. Should the user wish to fill it with synthetic oil, it is recommended to replace the existing plugs with a closed plug.
See table 1 for lubrication and recommended quantity.
In table 2 please see possible radial loads and axial loads on the gearbox.

I Il riduttore tipo **853C** è fornito privo di lubrificazione con tappi di sfiato, livello e scarico olio. L'utente può immettere olio minerale mantenendo i tappi esistenti. Se immetterà olio sintetico, dovrà sostituire i tappi esistenti con altri tipo chiuso.
Tab.1 per oli e quantità consigliati.
Tab.2 carichi radiali e assiali applicabili al riduttore.

D Das Getriebe der Baugröße **853C** wird ohne Schmiermittel geliefert. Es ist jedoch mit Einfüllschraube, Überdruckventil und Ablassschraube ausgerüstet. Das benötigte mineralische Öl kann über die Einfüllschraube eingefüllt werden. Sollte synthetisches Öl bevorzugt werden, so ist sind das eingebaute Überdruckventil durch eine geschlossenen Schraube zu ersetzen.
In Tabelle 1 ist die Schmiermenge und das empfohlene Schmiermittel angegeben
In Tabelle 2 sind die zulässigen Radial - und Axialbelastungen des Getriebes aufgeführt.

F Le réducteur de type **853C** est fourni sans lubrification et avec un bouchon de remplissage, de niveau et d'évacuation de l'huile. L'utilisateur peut y verser de l'huile minérale en conservant les bouchons existants. S'il y versera de l'huile synthétique, il devra substituer les bouchons existants avec d'autres bouchons de type fermé.
Voir tableau 1 concernant les huiles et les quantités conseillées.
Voir tableau 2 concernant les charges radiales et axiales applicables au réducteur

E El reductor tamaño **853C** se suministra sin lubricante, provisto de tapones de respiración, nivel y descarga de aceite. El usuario puede utilizar aceite mineral, manteniendo los tapones existentes. Si prefiere utilizar aceite sintético deberá sustituir los tapones existentes por tapones ciegos. La prerreducción se suministra con tapones ciegos, lubricado de por vida con aceite sintético.
Ver tabla 1, para cantidades y aceites recomendados.
En la tabla 2, se encuentran las cargas radiales y axiales admitidas por el reductor.

B3	B6	B7	B8	V5	V6	V8
5.50 LT	3.80 LT	3.80 LT	3.20 LT	7.00 LT	4.60 LT	Ask
AGIP Blasias 460						

For all details on lubrication and plugs check our website **tab. 1**
Per maggiori dettagli su lubrificazione e tappi olio vedi il nostro sito web

RADIAL AND AXIAL LOADS

Output shaft
Albero di uscita

$F_{eq} = FR \cdot \frac{88.5}{X+38.5}$

n_2	FA	FR	n_2	FA	FR	n_2	FA	FR
300	1800	9000	140	2400	12000	70	3000	15000
250	2000	10000	120	2600	13000	40	3200	16000
200	2200	11000	85	2800	14000	15	4000	20000

On request reinforced bearings to increase loads.
A richiesta cuscinetti rinforzati per aumentare i carichi.

Input shaft
Albero in entrata

n_1	FA	FR
1400	450	2250
900	500	2500
500	600	3000

tab. 2



- 1) 230/400V - 50Hz three-phase asynchronous induction motor
- 2) Class F insulation
- 3) S1 duty
- 4) IP 55 protection
- 5) Not painted
- 6) Hard plastic sleeve to protect output shaft during the transportation

- 1) 230/400V - 50Hz motore trifase asincrono
- 2) Isolamento Classe F
- 3) S1 servizio continuo
- 4) Protezione IP 55
- 5) Non verniciato
- 6) Manicotto di protezione per l'albero motore

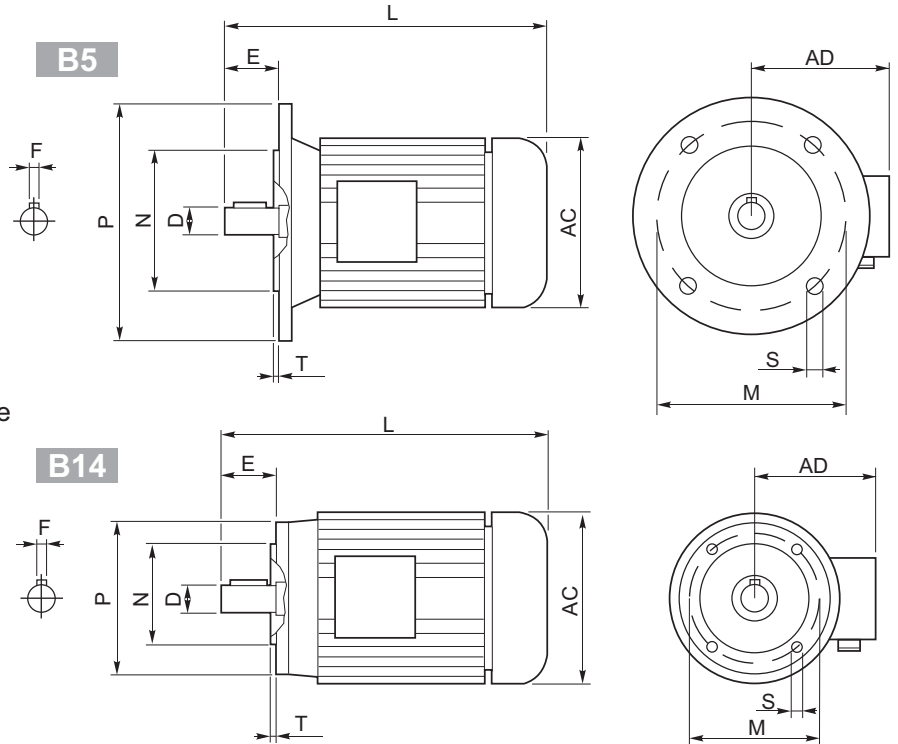

Outside dimensions and weight may be different according to manufacturers.
Le dimensioni esterne e il peso sono indicative, possono variare tra i vari costruttori.

	2 poli / poles			4 poli / poles			6 poli / poles			B5-B14					B5					B14					Kg	
	kW	Nm	A _(400V)	kW	Nm	A _(400V)	kW	Nm	A _(400V)	D	F	E	L	AC	AD	N	M	P	S	T	N	M	P	S		T
56 A	0.09	0.32	0.38	0.06	0.44	0.27	—	—	—	9	3	20	199	108	96	80	100	120	7	2.5	50	65	80	M5	2.5	2.7
56 B	0.12	0.42	0.46	0.09	0.67	0.37	—	—	—	9	3	20	199	108	96	80	100	120	7	2.5	50	65	80	M5	2.5	2.9
63 A	0.18	0.63	0.60	0.12	0.84	0.50	0.09	0.99	0.57	11	4	23	208	120	99	95	115	140	9.5	3	60	75	90	M5	2.5	3.8
63 B	0.25	0.87	0.76	0.18	1.30	0.69	0.12	1.32	0.74	11	4	23	208	120	99	95	115	140	9.5	3	60	75	90	M5	2.5	4.2
71 A	0.37	1.30	1.00	0.25	1.70	0.91	0.18	1.90	0.80	14	5	30	-	130	104	110	130	160	9.5	3.5	70	85	105	M6	2.5	5.9
71 B	0.55	1.90	1.54	0.37	2.52	1.14	0.25	2.72	1.10	14	5	30	255	141	107	110	130	160	9.5	3.5	70	85	105	M6	2.5	6.5
80 A	0.75	2.60	1.85	0.55	3.77	1.51	0.37	3.84	1.18	19	6	40	296	159	127	130	165	200	11.5	3.5	80	100	120	M6	3	8.5
80 B	1.1	3.90	2.64	0.75	5.11	2.57	0.55	5.84	1.80	19	6	40	296	159	127	130	165	200	11.5	3.5	80	100	120	M6	3	10
90 S	1.5	5.00	3.31	1.1	7.45	2.78	0.75	7.92	2.32	24	8	50	-	170	135	130	165	200	11.5	3.5	95	115	140	M8	3	12.5
90 L	2.2	7.50	4.46	1.5	10.2	3.61	1.1	11.6	3.45	24	8	50	330	170	135	130	165	200	11.5	3.5	95	115	140	M8	3	15
100 LA	3.0	10.0	6.28	2.2	14.8	5.07	1.5	15.4	3.88	28	8	60	-	190	148	180	215	250	13	4	110	130	160	M8	3.5	20
100 LB	—	—	—	3.0	20.1	6.66	—	—	—	28	8	60	-	190	148	180	215	250	13	4	110	130	160	M8	3.5	22
112 M	4.0	13.4	8.10	4.0	26.7	8.55	2.2	22.6	5.30	28	8	60	381	210	164	180	215	250	13	4	110	130	160	M8	3.5	35
132 S	5.5	18.3	11.2	5.5	36.5	11.4	3.0	30.2	7.20	38	10	80	455	244	180	230	265	300	14	4	130	165	200	M10	4	41
	7.5	24.9	15.3																							51
132 M	—	—	—	7.5	49.4	15.0	4.0	40.0	9.13	38	10	80	500	244	180	230	265	300	14	4	130	165	200	M10	4	51
	9	61.4	18.5	51																						
160 M	—	—	—	11	72	21.5	—	—	—	42	12	110	613	335	246	250	300	350	18	5	—	—	—	—	—	79.2
160 L	—	—	—	15	98	29	—	—	—	42	12	110	657	335	246	250	300	350	18	5	—	—	—	—	—	97.5
180 M	—	—	—	18.5	121	35.5	—	—	—	48	14	110	712	366	266	250	300	350	19	5	—	—	—	—	—	170
180 L	—	—	—	22	144	42	—	—	—	48	14	110	712	366	266	250	300	350	19	5	—	—	—	—	—	170
200 L	—	—	—	30	196	53	—	—	—	55	16	110	780	405	341	300	350	400	19	5	—	—	—	—	—	240
225 S	—	—	—	37	240	69	—	—	—	60	18	140	888	463	360	350	400	450	19	5	—	—	—	—	—	305
225 M	—	—	—	45	292	84	—	—	—	60	18	140	888	463	360	350	400	450	19	5	—	—	—	—	—	310



Protection

Standard IP55
Please specify on purchase orders if you need a higher IP protection class.

Grado di protezione

IP55 Standard
Specificare in sede di ordinazione per IP superiore.

Schutzart

IP55 Standard.
Höheren IP Grad bitte im Auftrag angeben.

Degré de protection

IP55 standard.
Au moment de la commande, spécifiez si vous souhaitez IP supérieur.

Grado de protección
IP55 standard.
Especificar en el pedido cuando necesiten protección IP superior.

Insulation

Standard CI.F
To be specified upon placing the order if different insulation is required.

Isolamento

CI.F Standard
Specificare in sede di ordinazione classe di isolamento diversa.

Isolierung

CI.F Standard.
Davon abweichende Isolierungsklasse im Auftrag angeben.

Isolement

CI.F Standard.
Au moment de la commande, spécifiez si vous souhaitez une classe d'isolement différente.

Aislamiento

CI.F standard.
Especificar al efectuar el pedido la clase diferente de aislamiento.

Insulation / Isolamento Isolierung /Aislamiento		E	B	F	H
Max. temp.	C°	120°	130°	155°	175°
	F*	248°	266°	311°	347°

Connections

Collegamenti

Verbindungselemente

Branchements

Conexiones

Threephase asynchronous single polarity
Asincrono trifase singola polarità
Asynchronmotor 3-ph eine Drehzahl
Moteur triphasé à une vitesse
Asincrono trifasico de una velocidad

Threephase asynchronous double polarity
Asincrono trifase doppia polarità
Asynchronmotor 3-ph doppelte Drehzahl
Moteur triphasé à deux vitesses
Asincrono trifasico de dos velocidades

Single phase asynchronous
Asincrono monofase
Einphasen-Asynchronmotor
Moteur monophasé
Asincrono monofasico

