

QUICK SELECTION / Selezione veloce

input speed (n_1) = 1400 min⁻¹

Output Speed n_2 [min ⁻¹]	Ratio i	Motor power P_{1M} [kW]	Output torque M_{2M} [Nm]	Service factor $f.s.$	Nominal power P_{1R} [kW]	Nominal torque M_{2R} [Nm]	Available B5 motor flanges					Available B14 motor flanges				Output Shaft \varnothing	Ratios code 	
							-C	-D	-E	-F	-G	-R	-T	-U	-V			
							71	80	90	100 112	132	80	90	100 112	132			
145	9.69	9	560	1.3	12.2	755	B										302418	01
126	11.09	9	641	1.1	9.6	680	B										302416	02
108	12.90	9	746	1.1	9.6	790	B										302414	03
77	18.26	7.5	849	1.1	8.0	935	B										202418	04
67	20.91	7.5	972	1.0	7.5	1000	B										202416	05
58	24.32	5.5	835	1.2	6.4	1000	B										202414	06
49.5	28.27	5.5	971	1.0	5.5	1000	B										162416	07
42.6	32.88	4	826	1.2	4.7	1000	B										162414	08
38.1	36.76	4	924	1.1	4.2	1000	B										132416	09
32.7	42.76	3	809	1.2	3.6	1000	B										132414	10
31.1	45.00	3	851	1.2	3.5	1000	B										112416	11
26.8	52.33	3	990	1.0	3.0	1000	B										112414	12
24.6	56.82	2.2	791	1.1	2.3	850	B										82418	13
21.5	65.07	2.2	906	1.1	2.3	975	B										82416	14
18.5	75.68	2.2	1054	0.9	2.1	1000	B										82414	15
15.6	89.61	1.1	628	1.1	1.2	710	B										62416	16
13.4	104.22	1.1	731	1.1	1.2	820	B										62414	17

The dynamic efficiency is **0.94** for all ratios

Motor Flanges Available
Flange Motore Disponibili

B) Supplied with Reduction Bushing
Fornito con Bussola di Riduzione

B) Available on Request without reduction bushing
Disponibile a Richiesta senza Bussola di Riduzione

C) Motor Flange Holes Position
Posizione Fori Flangia Motore

EN Unit **X83C** is supplied without lubricant and equipped with a breather, level and drain plugs. User can add mineral oil keeping existing plugs. Should the user wish to fill it with synthetic oil, it is recommended to replace the existing plugs with a closed plug. See table 1 for lubrication and recommended quantity. In table 2 please see possible radial loads and axial loads on the gearbox.

I Il riduttore tipo **X83C** è fornito privo di lubrificazione con tappi di sfiato, livello e scarico olio. L'utente può immettere olio minerale mantenendo i tappi esistenti. Se immetterà olio sintetico, dovrà sostituire i tappi esistenti con altri tipo chiuso. Tab.1 per oli e quantità consigliati. Tab.2 carichi radiali e assiali applicabili al riduttore.

D Das Getriebe der Baugröße **X83C** wird ohne Schmiermittel geliefert. Es ist jedoch mit Einfüllschraube, Überdruckventil und Ablassschraube ausgerüstet. Das benötigte mineralische Öl kann über die Einfüllschraube eingefüllt werden. Sollte synthetisches Öl bevorzugt werden, so ist sind das eingebaute Überdruckventil durch eine geschlossenen Schraube zu ersetzen. In Tabelle 1 ist die Schmiermenge und das empfohlene Schmiermittel angegeben. In Tabelle 2 sind die zulässigen Radial - und Axialbelastungen des Getriebes aufgeführt.

F Le réducteur de type **X83C** est fourni sans lubrification et avec un bouchon de remplissage, de niveau et d'évacuation de l'huile. L'utilisateur peut y verser de l'huile minérale en conservant les bouchons existants. S'il y versera de l'huile synthétique, il devra substituer les bouchons existants avec d'autres bouchons de type fermé. Voir tableau 1 concernant les huiles et les quantités conseillées. Voir tableau 2 concernant les charges radiales et axiales applicables au réducteur.

E El reductor tamaño **X83C** se suministra sin lubricante, provisto de tapones de respiración, nivel y descarga de aceite. El usuario puede utilizar aceite mineral, manteniendo los tapones existentes. Si prefiere utilizar aceite sintético deberá sustituir los tapones existentes por tapones ciegos. La prerreducción se suministra con tapones ciegos, lubricado de por vida con aceite sintético. Ver tabla 1, para cantidades y aceites recomendados. En la tabla 2, se encuentran las cargas radiales y axiales admitidas por el reductor.

B3	B6	B7	B8	V5	V6	V8
2.80 LT	3.10 LT	2.00 LT	2.50 LT	4.95 LT	2.80 LT	Ask

AGIP Blasias 460

For all details on lubrication and plugs check our website **tab. 1**
Per maggiori dettagli su lubrificazione e tappi olio vedi il nostro sito web

RADIAL AND AXIAL LOADS

Output shaft
Albero di uscita

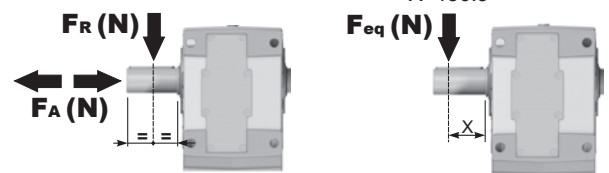

$$F_{eq} = F_R \cdot \frac{196.5}{X + 156.5}$$

n_2	FA	FR	n_2	FA	FR	n_2	FA	FR
300	1700	8500	140	1860	9300	70	2160	10800
250	1760	8800	120	1900	9500	40	2300	11500
200	1800	9000	85	1960	9800	15	2400	12000

On request reinforced bearings to increase loads.

A richiesta cuscinetti rinforzati per aumentare i carichi.

Input shaft

Albero in entrata

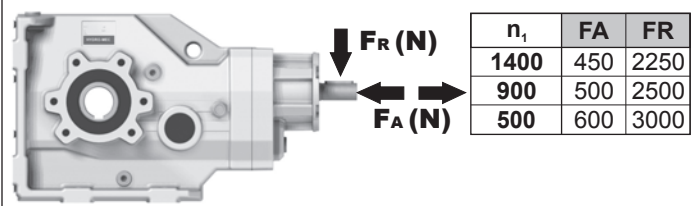

n_1	FA	FR
1400	450	2250
900	500	2500
500	600	3000

tab. 2

PX83CC... Basic gearbox
Riduttore base

Gearbox weight
peso riduttore **48.5 kg**

M. flanges	Kit code	øF	A
71B5	K023.4.041	160	315.7
80/90B5	K023.4.042	200	317.7
100/112B5	K023.4.043	250	326.7
132B5	KC50.4.043	300	344.7
80B14	K085.4.046	120	317.7
90B14	K085.4.045	140	317.7
100/112B14	K085.4.047	160	326.7
132B14	KC50.4.041	200	344.7

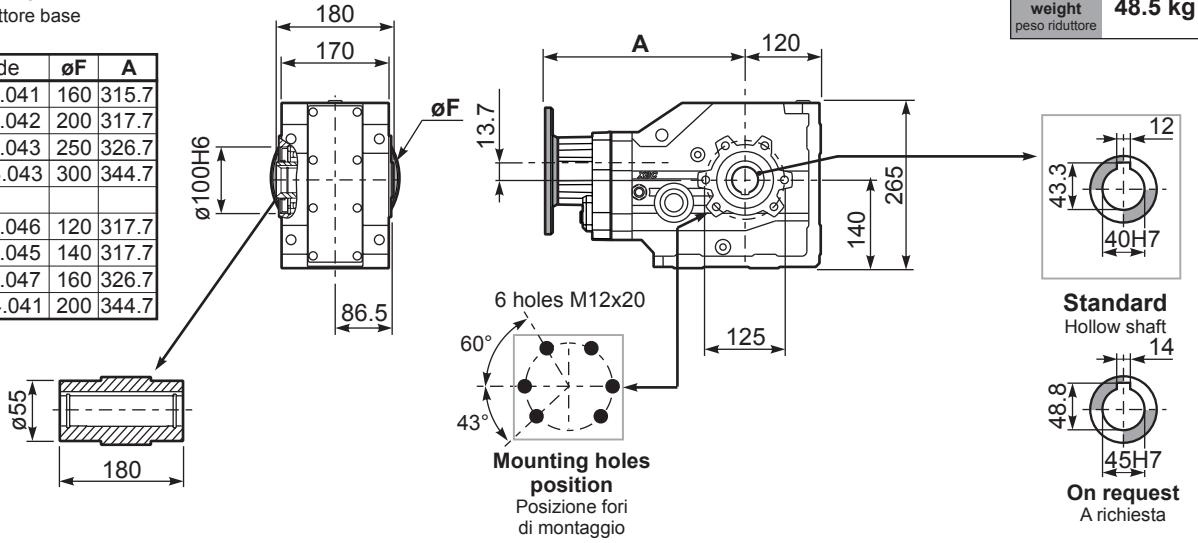

PX83C...FB.. Feet
Piedini

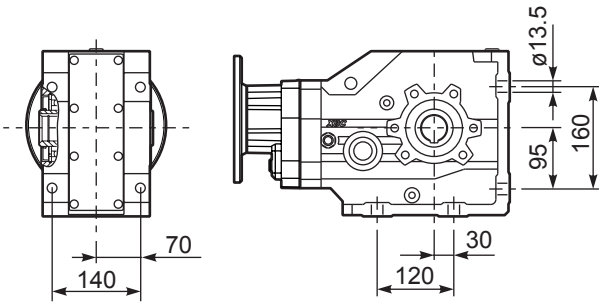

PX83C...-F4.. Output flange
Flangia uscita

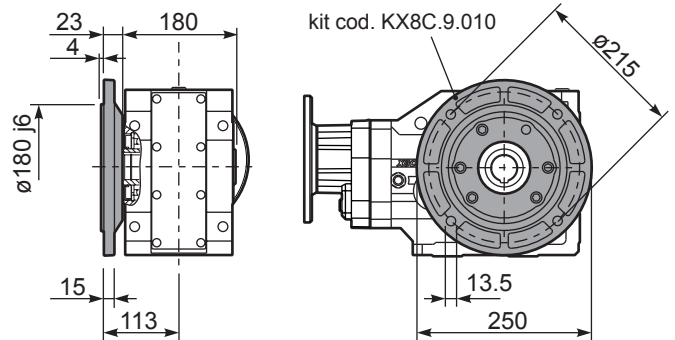

PX83C...BR.. Reaction Arm
Braccio di reazione

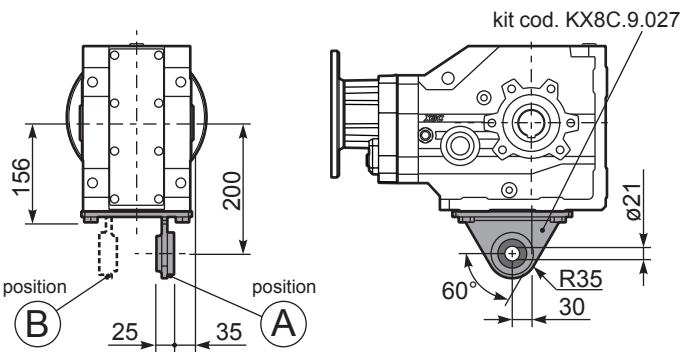

RX83C... Input shaft
Albero in entrata

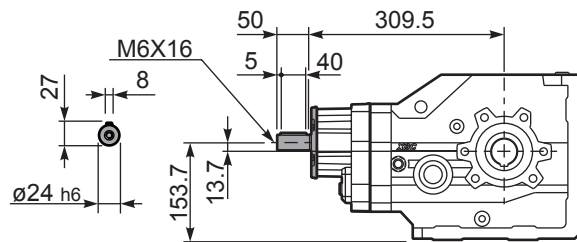

PX83CA... Single shaft
Albero lento semplice

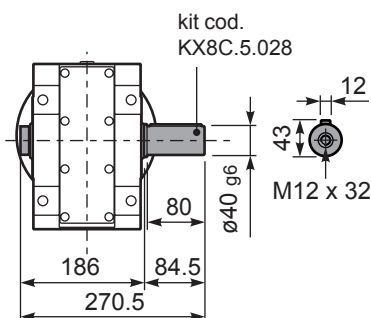

PX83CB... Double shaft
Albero lento bisp.

