



QUICK SELECTION / Selezione veloce

input speed (n_1) = 1400 min⁻¹

Output Speed n_2 [min ⁻¹]	Ratio i	Motor power P_{1M} [kW]	Output torque M_{2M} [Nm]	Service factor f.s.	Nominal power P_{1R} [kW]	Nominal torque M_{2R} [Nm]	Available B5 motor flanges					Available B14 motor flanges				Output Shaft 	Ratios code
							-C	-D	-E	-F	-G	-R	-T	-U	-V		
							71	80	90	100 112	132	80	90	100 112	132		
176	7.94	7.5	369	1.0	7.5	380	B									302418	01
153	9.13	7.5	425	0.9	6.7	390	B									302416	02
131	10.66	5.5	366	1.1	6.0	410	B									302414	03
94	14.97	5.5	514	1.1	6.0	580	B									202418	04
81	17.21	5.5	591	1.0	5.4	600	B									202416	05
69	20.24	5.5	695	1.0	5.2	675	B									162418	06
60	23.27	4	585	1.2	4.5	675	B									162416	07
53	26.31	4	661	1.0	4.0	675	B									132418	08
46.3	30.25	4	760	0.9	3.5	675	B									132416	09
39.6	35.32	3	668	1.0	3.0	675	B									132414	10
37.8	37.03	3	701	1.0	2.8	675	B									112416	11
32.4	43.23	2.2	602	1.1	2.4	675	B									112414	12
30.1	46.58	2.2	649	1.0	2.3	675	B									82418	13
26.1	53.55	2.2	746	0.9	2.0	675	B									82416	14
22.4	62.52	1.5	600	1.1	1.7	675	B									82414	15
19.0	73.75	1.1	517	1.1	1.2	580	B									62416	16
16.3	86.09	1.1	604	1.1	1.2	675	B									62414	17

The dynamic efficiency is **0.94** for all ratios

- Motor Flanges Available**
Flange Motore Disponibili
- B) Supplied with Reduction Bushing**
Fornito con Bussola di Riduzione
- B) Available on Request without reduction bushing**
Disponibile a Richiesta senza Bussola di Riduzione
- C) Motor Flange Holes Position**
Posizione Fori Flangia Motore

EN Unit **X73C** is supplied with synthetic oil for lifetime lubrication, no maintenance is necessary. See table 1 for lubrication and recommended quantity. In table 2 please see possible radial loads and axial loads on the gearbox.

I Il riduttore **X73C** viene fornito completo di olio sintetico per la lubrificazione permanente e non necessita di alcuna manutenzione. Vedi tab.1 per oli e quantità consigliati. In tab.2 sono presenti i carichi radiali e assiali applicabili al riduttore.

D Das Getriebe **X73C** ist mit synthetischem Öl gefüllt und ist lebensdauer geschmiert. In Tabelle 1 ist die Schmiermenge und das empfohlene Schmiermittel angegeben. In Tabelle 2 sind die zulässigen Radial - und Axialbelastungen des Getriebes aufgeführt.

F Le réducteur **X73C** est fourni complet avec de l'huile synthétique pour la lubrification permanente et ne nécessite aucun entretien. Voir tableau 1 concernant les huiles et les quantités conseillées. Les charges radiales et axiales applicables au réducteur sont précisées dans le tableau 2.

E El reductor tamaño **X73C** se suministra, lubricado de por vida con aceite sintético y no requieren mantenimiento alguna. Ver tabla 1, para cantidades y aceites recomendados. En la tabla 2, se encuentran las cargas radiales y axiales admitidas por el reductor.

Standard supplied	For these mounting position specify in the order or add oil Per queste posizioni specificare in fase d'ordine o aggiungere olio					
2.45 LT	2.55 LT	1.80 LT	1.95 LT	4.05 LT	2.55 LT	Ask
AGIP Telium VSF 320			SHELL Omala S4 WE 320			

For all details on lubrication and plugs check our website [tab. 1](#)
Per maggiori dettagli su lubrificazione e tappi olio vedi il nostro sito web

RADIAL AND AXIAL LOADS

Output shaft
Albero di uscita

$F_{eq} = FR \cdot \frac{178.5}{X+143.5}$

n_2	FA	FR	n_2	FA	FR	n_2	FA	FR
300	1360	6800	140	1480	7400	70	1720	8600
250	1400	7000	120	1520	7600	40	1840	9200
200	1440	7200	85	1560	7800	15	1920	9600

On request reinforced bearings to increase loads.
A richiesta cuscinetti rinforzati per aumentare i carichi.

Input shaft
Albero di entrata

n_1	FA	FR
1400	400	2000
900	440	2200
500	440	2200

tab. 2

PX73CC... Basic Gearbox
Riduttore base

Gearbox weight
peso riduttore **41.0 kg**

M. flanges	Kit code	øF	A
71B5	K023.4.041	160	298.9
80/90B5	K023.4.042	200	300.9
100/112B5	K023.4.043	250	309.9
132B5	KC50.4.043	300	327.9
80B14	K085.4.046	120	300.9
90B14	K085.4.045	140	300.9
100/112B14	K085.4.047	160	309.9
132B14	KC50.4.041	200	327.9

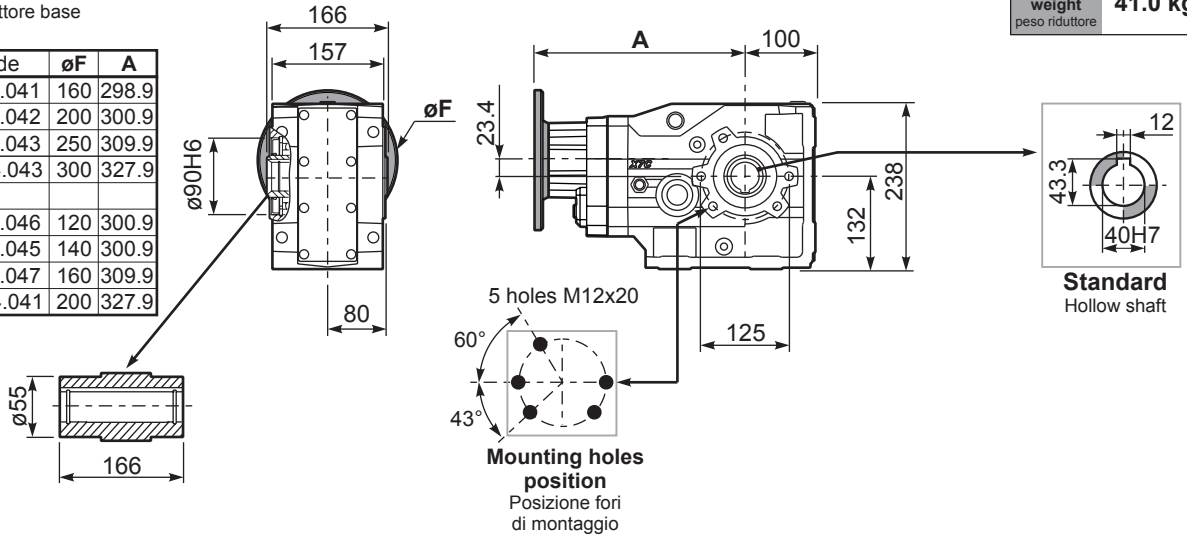

PX73C...FB.. Feet
Piedini

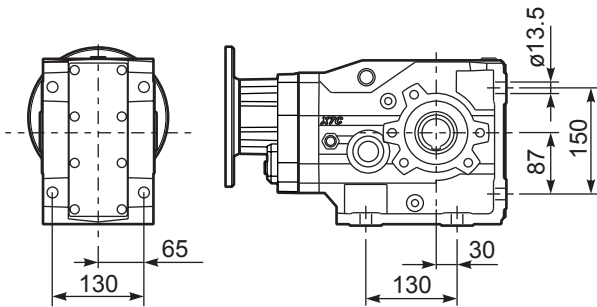

PX73C...-F4.. Output flange
Flangia uscita

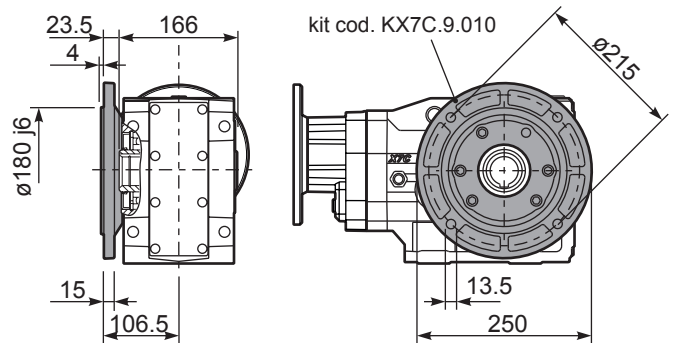

PX73C...BR.. Reaction Arm
Braccio di reazione

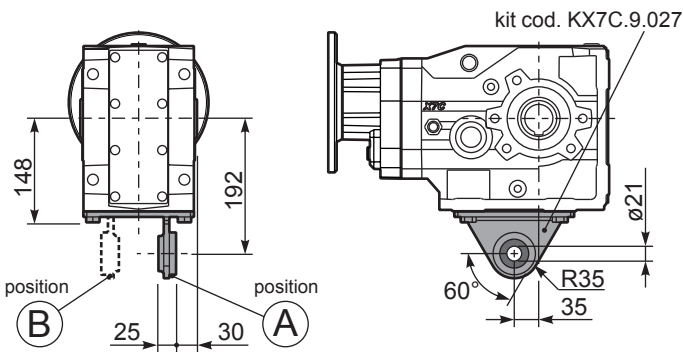

RX73C... Input shaft
Albero in entrata

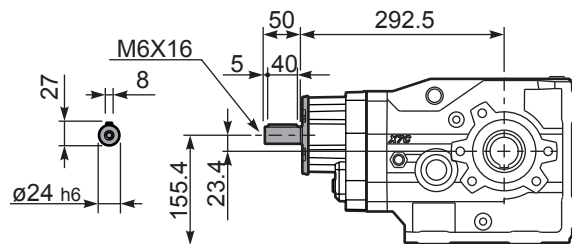

PX73CA... Single shaft
Albero lento semplice

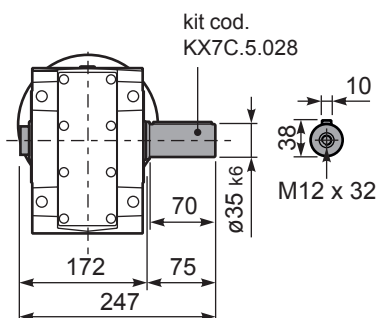

PX73CB... Double shaft
Albero lento bisp.

