



QUICK SELECTION / Selezione veloce

input speed (n_1) = 1400 min⁻¹

Output Speed n_2 [min ⁻¹]	Ratio i	Motor power P_{1M} [kW]	Output torque M_{2M} [Nm]	Service factor f.s.	Nominal power P_{1R} [kW]	Nominal torque M_{2R} [Nm]	Available B5 motor flanges		Available B14 motor flanges			Output Shaft \varnothing	Ratios code
							-B	-C	-O	-P	-Q		
							63	71	56	63	71		
36.5	38.40	0.37	91	1.8	0.67	165			C	C		171713	02
32.0	43.69	0.37	104	1.6	0.59	165			C	C		191712	03
27.6	50.64	0.37	120	1.4	0.51	165			C	C		171712	04
26.2	53.36	0.37	127	1.3	0.47	160			C	C		191710	05
22.9	61.21	0.37	145	1.2	0.43	170			C	C		191312	06
22.6	61.85	0.37	147	1.1	0.40	160			C	C		171710	07
19.7	70.95	0.37	168	1.0	0.37	170			C	C		131712	08
19.1	73.43	0.37	174	1.0	0.37	175			C	C		101713	09
18.7	74.77	0.37	177	0.9	0.33	160			C	C		191310	10
16.2	86.66	0.25	139	1.2	0.29	160			C	C		131710	11
14.5	96.85	0.25	155	1.1	0.27	170			C	C		101712	12
13.6	102.89	0.25	165	1.1	0.27	175			C	C		101313	13
11.1	126.40	0.18	155	1.1	0.21	170			C	C		91712	17
10.3	135.69	0.18	166	1.0	0.20	170			C	C		101312	15
8.4	165.74	0.12	131	1.2	0.15	160			C	C		101310	16
7.9	177.09	0.12	140	1.2	0.15	170			C	C		91312	18
6.5	216.31	0.09	136	1.2	0.12	160			C	C		91310	19

The dynamic efficiency is **0.94** for all ratios

Motor Flanges Available
Flange Motore Disponibili

B) Supplied with Reduction Bushing
Fornito con Bussola di Riduzione

B) Available on Request without reduction bushing
Disponibile a Richiesta senza Bussola di Riduzione

C) Motor Flange Holes Position
Posizione Fori Flangia Motore

EN Unit **413A** is supplied with synthetic oil for lifetime lubrication, no maintenance is necessary.
See table 1 for lubrication and recommended quantity.
In table 2 please see possible radial loads and axial loads on the gearbox.

I Il riduttore **413A** viene fornito completo di olio sintetico per la lubrificazione permanente e non necessita di alcuna manutenzione.
Vedi tab.1 per oli e quantità consigliati.
In tab.2 sono presenti i carichi radiali e assiali applicabili al riduttore.

D Das Getriebe **413A** ist mit synthetischem Öl gefüllt und ist lebensdauergeschmiert.
In Tabelle 1 ist die Schmiermenge und das empfohlene Schmiermittel angegeben.
In Tabelle 2 sind die zulässigen Radial - und Axialbelastungen des Getriebes aufgeführt.

F Le réducteur **413A** est fourni complet avec de l'huile synthétique pour la lubrification permanente et ne nécessite aucun entretien.
Voir tableau 1 concernant les huiles et les quantités conseillées.
Les charges radiales et axiales applicables au réducteur sont précisées dans le tableau 2.

E El reductor tamaño **413A** se suministra, lubricado de por vida con aceite sintético y no requieren mantenimiento alguna.
Ver tabla 1, para cantidades y aceites recomendados.
En la tabla 2, se encuentran las cargas radiales y axiales admitidas por el reductor.

Standard supplied	For these mounting position specify in the order or add oil Per queste posizioni specificare in fase d'ordine o aggiungere olio						
0.30 LT	0.35 LT	0.45 LT	0.45 LT	0.45 LT	0.55 LT	Ask	
SHELL Omala S4 WE 320				ENI Telium VSF 320			

For all details on lubrication and plugs check our website **tab. 1**
Per maggiori dettagli su lubrificazione e tappi olio vedi il nostro sito web

RADIAL AND AXIAL LOADS									
Output shaft Albero di uscita					$F_{eq} = FR \cdot \frac{46}{X+21}$				
n_2	FA	FR	n_2	FA	FR	n_2	FA	FR	
300	310	1550	140	406	2030	70	540	2700	
250	330	1650	120	448	2240	40	600	3000	
200	360	1800	85	480	2400	15	600	3000	
Input shaft Albero di entrata									
n_1	FA	FR							
1400	140	700							
900	160	800							
500	190	950							

tab. 2

P413A **B1** ... With feet
Con piedini

Gearbox weight **6.1 kg**
peso riduttore With feet **6.3 kg**

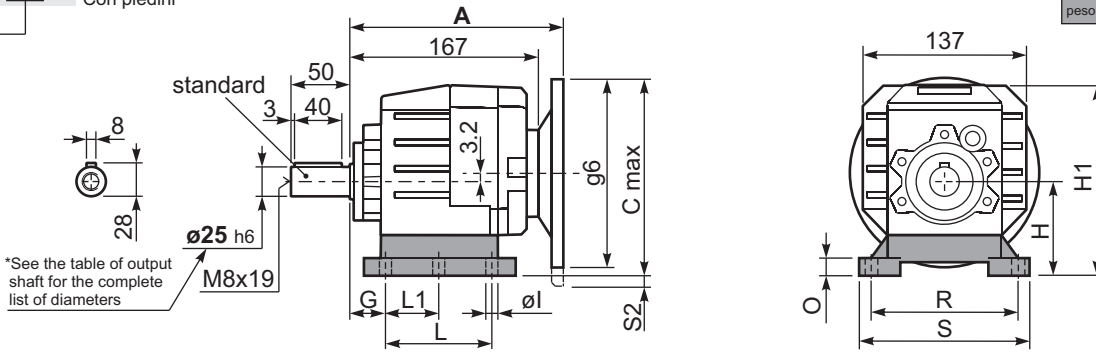

Feet / piedini

Feet Code	Market reference	G	H	R	L	L1	S	H1	O	øl	S2 only with motor flange	B5 max. Flange	kit code
B1	112	18	85	110	87	50	130	167.5	15	-	-	-	KC35.9.021
B2	212/3	18	100	130	107.5	60	155	182.5	17	11	-	-	KC40.9.025
S1	17	18	75	110	90+110	50	145	155.5	15	9	2 80/90B5	-	KC40.9.022
S2	27	25	90	110	130	-	145	172.5	20	9	-	-	KC40.9.024
H2	022-223	25	100	110	115	-	145	182.5	20	9	-	-	KC40.9.026
M1	42/3	25	80	110+120	85	-	145	162.5	15	9	-	-	KC40.9.023

Other feet are available, see our web site
Sono disponibili altri piedini, consulta il nostro sito web

A see on page bottom

Most popular types
Tipi più diffusi

P413A-**F** ... Output flanges
flange di uscita

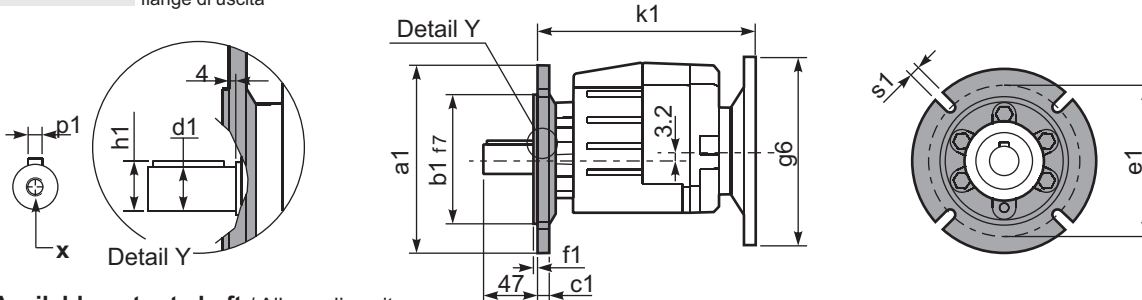

***Available output shaft / Albero di uscita**

	Shaft - d1	p1	h1	x
Standard	ø 25x50	8	28	M8x19
On request A richiesta	ø 16x40	5	18	M6x16
	ø 19x40	6	21.5	M6x16
	ø 20x40	6	22.5	M8x19
	ø 24x50	8	27	M8x19

Available output flanges / flange di uscita

a1 ø	b1	c1	e1	f1	s1	kit code
120	80	10	100	3	7	KC40.9.010
140	95	10	115	3	9	KC40.9.011
160	110	10	130	3.5	9	KC40.9.012
200	130	10	165	3.5	11	KC40.9.013
250	180	11.5	215	3.5	14	KC40.9.014

With flange and feet only on request. Ask for compatibility

P413A-**N** ... Basic gearbox
Riduttore base

Suggested B14 motor flanges

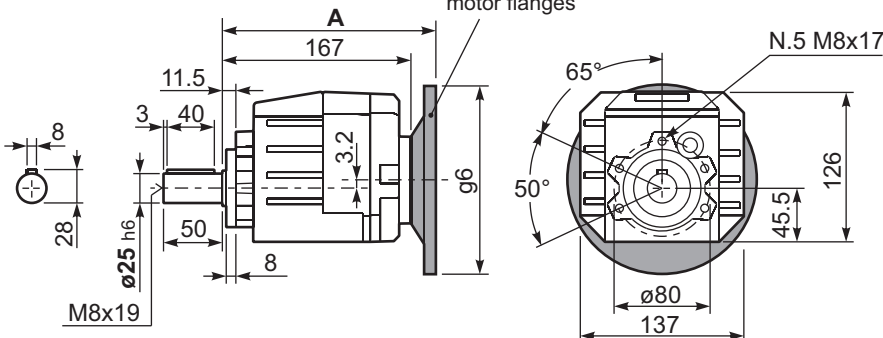

R413A-**N** ... Input Shaft
Albero in entrata

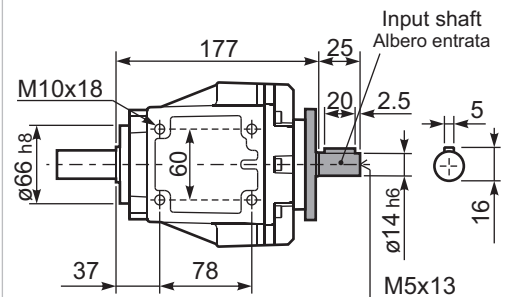

B5 Motor Flanges	A	C _{max}	g6	k1	kit code
63 B5	185.5	173.2	140	189.5	K050.4.041
71 B5	183	183.2	160	187	K050.4.042

B14 Motor Flanges	A	C _{max}	g6	k1	kit code
56 B14	183	143.2	80	187	KC40.4.049
63 B14	185.5	148.2	90	189.5	K050.4.047
71 B14	183	155.7	105	187	K050.4.045