



### QUICK SELECTION / Selezione veloce

input speed (n<sub>1</sub>) = 1400 min<sup>-1</sup>

Output Speed n <sub>2</sub> [min <sup>-1</sup> ]	Ratio i	Motor power P <sub>1M</sub> [kW]	Output torque M <sub>2M</sub> [Nm]	Service factor f.s.	Nominal power P <sub>1R</sub> [kW]	Nominal torque M <sub>2R</sub> [Nm]	Available B5 motor flanges				Available B14 motor flanges			Dynamic efficiency RD	Tooth Module [mm]	Ratios code
							-B	-C	-D	-E	-Q	-R	-T			
							63	71	80	90	71	80	90			
22	<b>62.9</b>	0.75	248	1.2	<b>0.87</b>	<b>286</b>					C	C		77	3.10	01
18	<b>78.5</b>	0.75	293	1.0	<b>0.73</b>	<b>286</b>					C	C		73	2.41	02
15	<b>94.2</b>	0.75	333	0.9	<b>0.70</b>	<b>310</b>					C	C		69	2.10	03
11	<b>126</b>	0.55	297	1.0	<b>0.55</b>	<b>296</b>	B				C	C		63	1.53	04
9	<b>157</b>	0.37	230	1.1	<b>0.41</b>	<b>252</b>	B				C	C		58	1.23	05
8	<b>185</b>	0.37	257	1.2	<b>0.43</b>	<b>296</b>	B				C	C		55	3.10	06
6	<b>231</b>	0.25	193	1.5	<b>0.38</b>	<b>296</b>	B				C	C		49	2.41	07
5	<b>277</b>	0.25	222	1.3	<b>0.33</b>	<b>296</b>	B				C	C		47	2.10	08
4	<b>378</b>	0.18	200	1.5	<b>0.27</b>	<b>296</b>	B				C	C		43	2.10	09

**A** Motor Flanges Available  
Flange Motore Disponibili

**B** Supplied with Reduction Bushing  
Fornito con Bussola di Riduzione

**B** Available on Request without reduction bushing  
Disponibile a Richiesta senza Bussola di Riduzione

**C** Motor Flange Holes Position  
Posizione Fori Flangia Motore

\* Power higher than the maximum one which can be supported by the gearbox. Select according to the torque M<sub>2R</sub>  
Potenza superiore a quella massima sopportabile dal riduttore. Selezionare in base al momento torcente M<sub>2R</sub>

**EN** Unit P7Q is supplied with synthetic oil, providing "long life" lubrication. For mounting position V5-V6 please contact us. See table 1 for lubrication and recommended quantity. In table 2 please see possible radial loads and axial loads on the gearbox.

**I** Il riduttore tipo P7Q viene fornito lubrificato a vita con olio sintetico. Per posizioni V5-V6 contattare il ns. servizio tecnico. Vedi tab.1 per oli e quantità consigliati. In tab.2 sono presenti i carichi radiali e assiali applicabili al riduttore.

**D** Für die Lebensdauerschmierung ist das Getriebe der Größe P7Q mit synthetischem Öl befüllt. Bei Einbaulage V5 oder V6 bitten wir um Rücksprache. In Tabelle 1 ist die Schmiermenge und das empfohlene Schmiermittel angegeben. In Tabelle 2 sind die zulässigen Radial- und Axialbelastungen des Getriebes aufgeführt.

**F** Le réducteur de type P7Q est fourni lubrifié à vie avec de l'huile synthétique. Concernant les positions V5.V6, contactez notre service d'assistance technique. Voir tableau 1 concernant les huiles et les quantités conseillées. Les charges radiales et axiales applicables au réducteur sont précisées dans le tableau 2.

**E** El reductor tamaño P7Q se suministra, lubricado de por vida con aceite sintético. Para las posiciones V5 y V6 contactar con nuestro servicio técnico. Ver tabla 1, para cantidades y aceites recomendados. En la tabla 2, se encuentran las cargas radiales y axiales admitidas por el reductor.

### LUBRICATION P7Q Oil

For B3-V5-V6 separate lubrication for A (0.40 l) B (0.14 l), for B6-B7-B8 common lubrication 0.65 l (A + B).

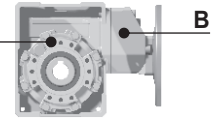

AGIP Telium VSF 320

SHELL Omala S4 WE 320

For all details on lubrication and plugs check our website **tab. 1**  
Per maggiori dettagli su lubrificazione e tappi olio vedi il nostro sito web

### RADIAL AND AXIAL LOADS

#### Output shaft

Albero di uscita

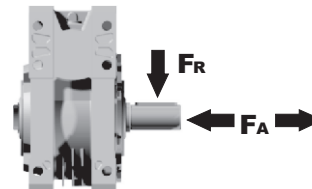

n <sub>2</sub> [min <sup>-1</sup> ]	FA [N]	FR [N]
75	620	3100
50	720	3600
25	880	4400
15-6	1000	5000

#### Input shaft

albero in entrata

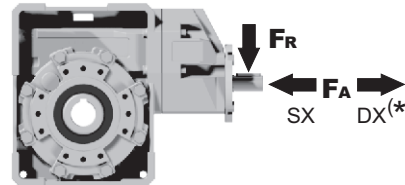

n [min <sup>-1</sup> ]	FA [N]	FR [N]
1400	108	540

\*Strong axial loads in the DX direction are not allowed.  
Non sono consentiti forti carichi assiali con direzione DX

tab. 2

PP7Q**FB**... Basic wormbox  
Riduttore base

Gearbox weight  
peso riduttore **9.90 kg**

M. flanges	Kit code	øF	A
63B5	K063.4.041	140	192.7
71B5	K063.4.042	160	190.7
80/90B5	K063.4.043	200	192.7
71B14	K063.4.047	105	190.7
80B14	K063.4.046	120	192.7
90B14	K063.4.041	140	192.7

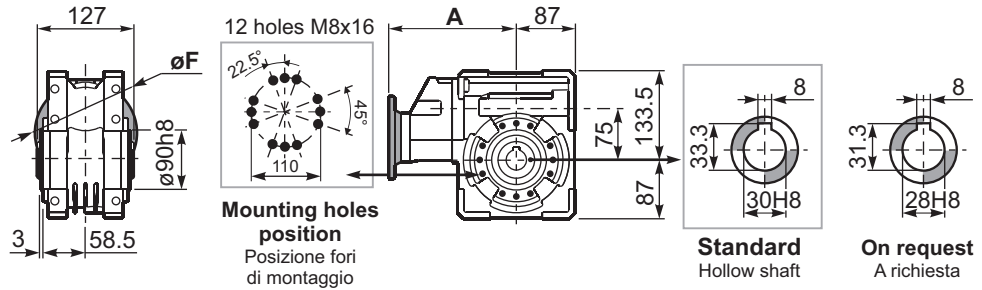

PP7Q**FC**... Square flange  
Flangia quadrata

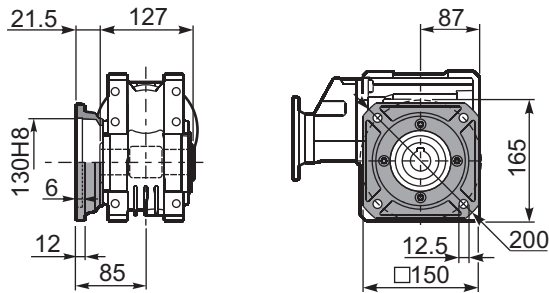

PP7Q**FL**... Square flange  
Flangia quadrata

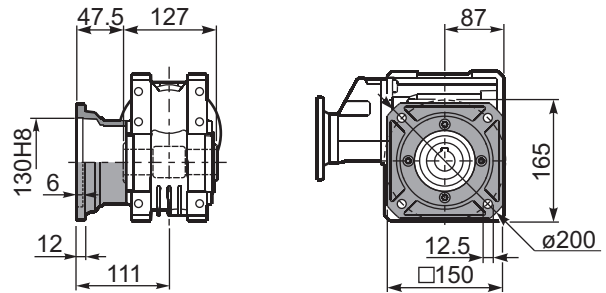

PP7Q**FB**... Feet  
Piedini

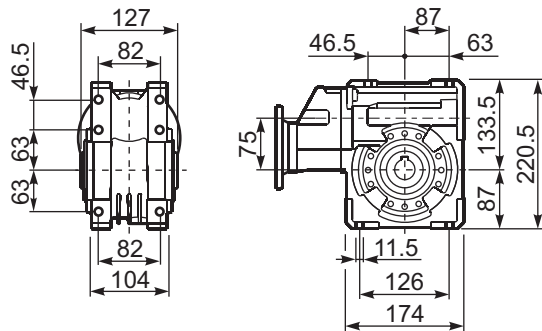

PP7Q**BR**... Reaction arm  
Braccio di reazione

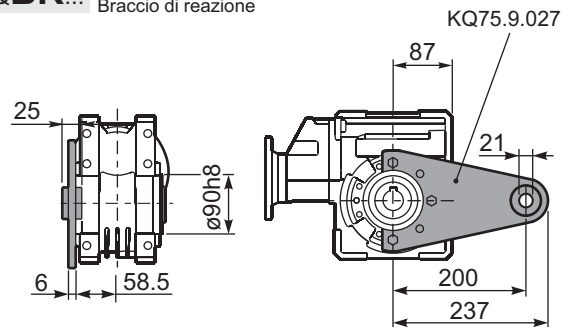

RP7Q**FB**... Input shaft  
Albero in entrata

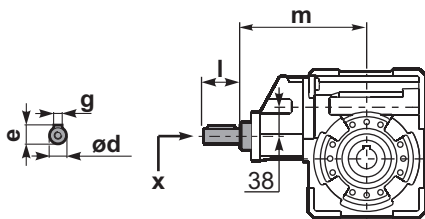

PP7Q....**S**... Single Shaft  
Albero lento semplice

PP7Q....**D**... Double Shaft  
Albero lento bisp.

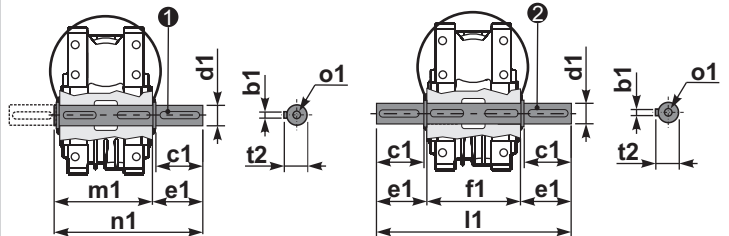

① kit cod. KQ75.5.028 Standard  
kit cod. KQ75.5.026 On request

② kit cod. KQ75.5.029 Standard  
kit cod. KQ75.5.027 On request

	ød	e	g	l	m	x	
type B	19 h6	21.5	6	35	185.5	M6x16	C40.5.062
type S	-	-	-	-	-	-	

	b1	c1	d1	e1	f1	l1	m1	n1	t2	o1
Standard	8	60	30 <sup>-0.005</sup> <sub>-0.020</sub>	65	127	255	134	199	33	M8x20
On request	8	50	28 <sup>-0.005</sup> <sub>-0.020</sub>	65	127	255	134	199	31	M8x20