

QUICK SELECTION / Selezione veloce

input speed (n_1) = 1400 min⁻¹

Output Speed n_2 [min ⁻¹]	Ratio i	Motor power P_{1M} [kW]	Output torque M_{2M} [Nm]	Service factor f.s.	Nominal power P_{1R} [kW]	Nominal torque M_{2R} [Nm]	Available B5 motor flanges			Available B14 motor flanges		Dynamic efficiency RD	Tooth Module [mm]	Ratios code
							-A	-B	-C	-P	-Q			
							56	63	71	63	71			
47	30.1	0.25	38	1.4	0.36	55				C		74	2.2	01
33	43.0	0.25	53	1.0	0.26	55				C		72	2.2	02
23	60.2	0.25	62	0.9	0.22	55				C		60	2.4	03
15.5	90.3	0.12	42	1.3	0.16	55				C		57	1.6	04
11.6	120	0.12	52	1.1	0.13	55				C		53	2.5	05
8.8	159	0.12	64	0.9	0.10	55				C		49	1.8	06
7.1	198	0.12*	55	<0.8	0.09	55				C		47	1.5	07
5.4	258	0.12*	55	<0.8	0.07	55				C		45	1.2	08
4.7	301	0.12*	39	<0.8	0.05	39				C		40	1.0	09
3.2	439	0.12*	39	<0.8	0.04	39				C		36	0.72	10

A) Motor Flanges Available
Flange Motore Disponibili

B) Supplied with Reduction Bushing
Fornito con Bussola di Riduzione

Available on Request without reduction bushing
Disponibile a Richiesta senza Bussola di Riduzione

C) Motor Flange Holes Position
Posizione Fori Flangia Motore

* Power higher than the maximum one which can be supported by the gearbox. Select according to the torque M_{2R}
Potenza superiore a quella massima sopportabile dal riduttore. Selezionare in base al momento torcente M_{2R}

EN Unit **P4Q** is supplied with synthetic oil, providing "long life" lubrication. For mounting position V5-V6 please contact us. See table 1 for lubrication and recommended quantity. In table 2 please see possible radial loads and axial loads on the gearbox.

I Il riduttore tipo **P4Q** viene fornito lubrificato a vita con olio sintetico. Per posizioni V5-V6 contattare il ns. servizio tecnico. Vedi tab.1 per oli e quantità consigliati. In tab.2 sono presenti i carichi radiali e assiali applicabili al riduttore.

D Für die Lebensdauerschmierung ist das Getriebe der Größe **P4Q** mit synthetischem Öl befüllt. Bei Einbaulage V5 oder V6 bitten wir um Rücksprache. In Tabelle 1 ist die Schmiermenge und das empfohlene Schmiermittel angegeben. In Tabelle 2 sind die zulässigen Radial- und Axialbelastungen des Getriebes aufgeführt.

F Le réducteur de type **P4Q** est fourni lubrifié à vie avec de l'huile synthétique. Concernant les positions V5.V6, contactez notre service d'assistance technique. Voir tableau 1 concernant les huiles et les quantités conseillées. Les charges radiales et axiales applicables au réducteur sont précisées dans le tableau 2.

E El reductor tamaño **P4Q** se suministra, lubricado de por vida con aceite sintético. Para las posiciones V5 y V6 contactar con nuestro servicio técnico. Ver tabla 1, para cantidades y aceites recomendados. En la tabla 2, se encuentran las cargas radiales y axiales admitidas por el reductor.

LUBRICATION P4Q Oil
Common lubrication 0.17 l (A + B).

AGIP Telium VSF 320	SHELL Omala S4 WE 320
----------------------------	------------------------------

For all details on lubrication and plugs check our website **tab. 1**
Per maggiori dettagli su lubrificazione e tappi olio vedi il nostro sito web

RADIAL AND AXIAL LOADS

Output shaft
Albero di uscita

n_2 [min ⁻¹]	FA [N]	FR [N]
75	240	1200
50	260	1400
25	300	1800
15-6	400	2000

Input shaft
albero in entrata

n_1 [min ⁻¹]	FA [N]	FR [N]
1400	44	220

*Strong axial loads in the DX direction are not allowed.
Non sono consentiti forti carichi assiali con direzione DX

tab. 2

PP4QFB... Basic wormbox
Riduttore base

M. flanges	Kit code	øF	A
56B5	K050.4.046	120	143.5
63B5	K050.4.041	138	145.5
71B5	K050.4.042	160	143
63B14	K050.4.047	90	145.5
71B14	K050.4.045	105	143

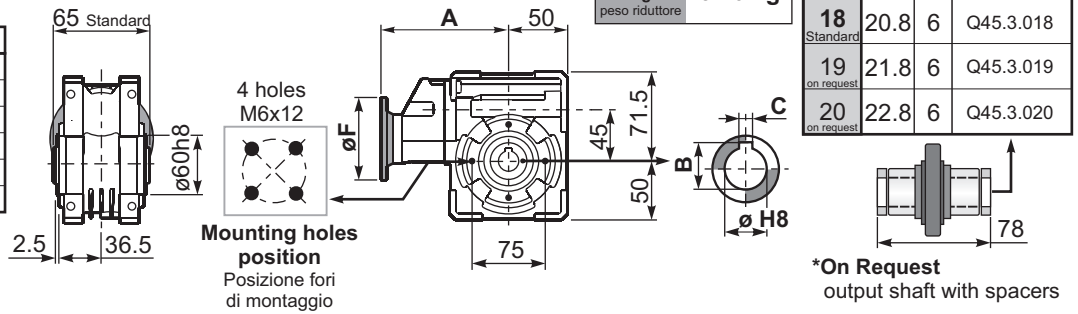

PP4QFC... Square flange
Flangia quadrata

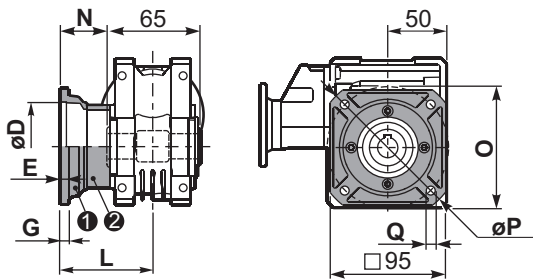

type B	øD	E	G	L	N	O	P	Q	kit code
FC	60 H8	4	7	67	34.5	75	110	9	KQ45.9.010
FL	60 H8	4	7	97	64.5	75	110	9	KQ45.9.011

PP4QF1... Round flange
Flangia rotonda

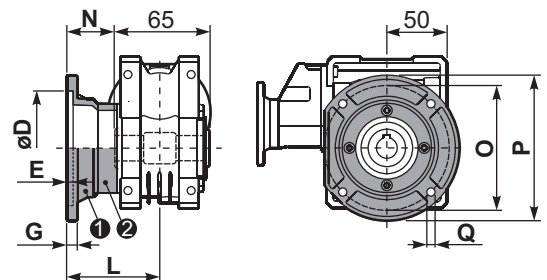

type S	øD	E	G	L	N	O	P	Q	kit code
F1	95H8	5	9	80	47.5	115	140	9.5	KSQ45.9.012
F2	80H8	5	12	58	25.5	100	120	9	KSQ45.9.013

PP4QFB... Feet
Piedini

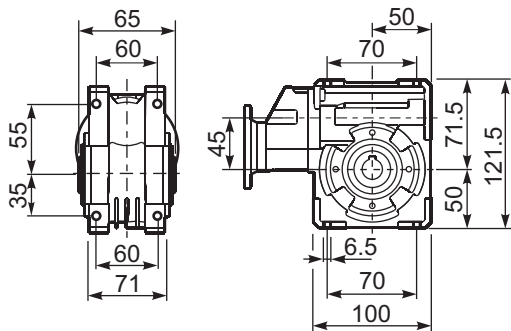

PP4QBR... Reaction arm
Braccio di reazione

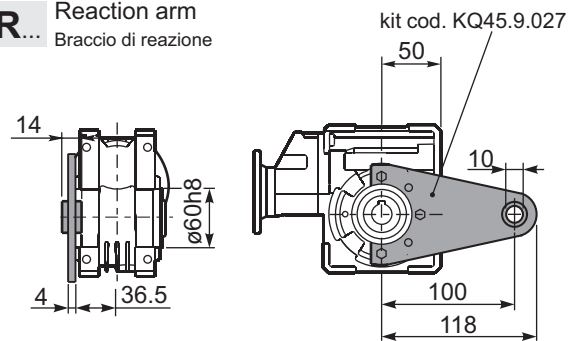

RP4QFB... Input shaft
Albero in entrata

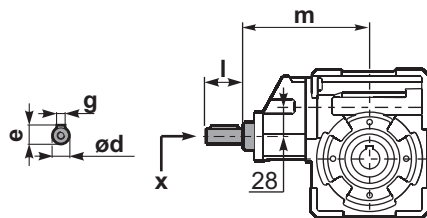

	ød	e	g	l	m	x	
type B	14 h6	16	5	25	141	M5x13	C35.5.061
type S	-	-	-	-	-	-	

PP4Q.....S... Single Shaft
Albero lento semplice

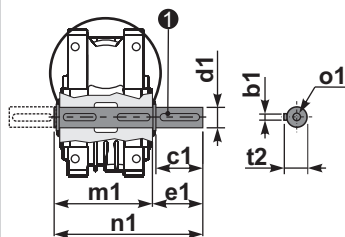

PP4Q.....D... Double Shaft
Albero lento bisp.

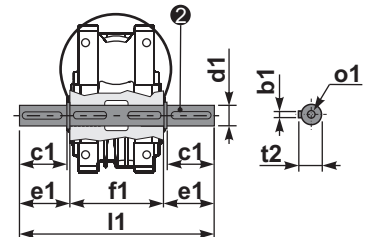

① kit cod. K045.5.028 type B
kit cod. KS045.5.030 type S

② kit cod. K045.5.029 type B
kit cod. KS045.5.031 type S

	b1	c1	d1	e1	f1	l1	m1	n1	t2	o1
type B	6	32	18 ^{-0.005} _{-0.020}	43	65	151	70	113	20.5	M6x18
type S	6	40	19 ^{-0.005} _{-0.020}	58.5	65	182	70	128.5	21.5	M8x20