



### QUICK SELECTION / Selezione veloce

input speed ( $n_1$ ) = 1400 min<sup>-1</sup>

Output Speed $n_2$ [min <sup>-1</sup> ]	Ratio $i$	Motor power $P_{1M}$ [kW]	Output torque $M_{2M}$ [Nm]	Service factor f.s.	Nominal power $P_{1R}$ [kW]	Nominal torque $M_{2R}$ [Nm]	Available B5 motor flanges				Available B14 motor flanges			Output Shaft 	Ratios code
							-B	-C	-D	-E	-Q	-R	-T		
							63	71	80	90	71	80	90		
22.6	<b>61.89</b>	1.1	434	1.2	1.3	510	B				C	C		191318	01
19.7	<b>71.16</b>	1.1	499	1.0	1.1	510	B				C	C		191316	02
17.0	<b>82.48</b>	1.1	578	0.9	0.96	510	B				C	C		171316	03
14.5	<b>96.29</b>	0.75	463	1.1	0.83	510	B				C	C		171314	04
13.9	<b>100.51</b>	0.75	483	1.1	0.79	510	B				C	C		131318	05
12.1	<b>115.56</b>	0.55	410	1.2	0.69	510	B				C	C		131316	06
11.1	<b>125.96</b>	0.55	447	1.1	0.63	510	B				C	C		190816	07
10.4	<b>134.91</b>	0.55	479	1.1	0.59	510	B				C	C		131314	08
9.5	<b>147.05</b>	0.55	522	1.0	0.54	510	B				C	C		190814	09
8.2	<b>170.44</b>	0.37	404	1.3	0.47	510	B				C	C		170814	10
7.6	<b>184.15</b>	0.37	437	1.2	0.43	510	B				C	C		101314	11
6.8	<b>205.87</b>	0.37	488	1.0	0.39	510	B				C	C		91316	12
5.8	<b>240.34</b>	0.37	570	0.9	0.33	510	B				C	C		91314	13
5.0	<b>279.22</b>	0.25	447	1.1	0.28	510	B				C	C		100816	14
4.3	<b>325.97</b>	0.25	522	1.0	0.24	510	B				C	C		100814	15
3.8	<b>364.41</b>	0.18	446	1.1	0.22	510	B				C	C		90816	16
3.3	<b>425.43</b>	0.18	521	1.0	0.19	510	B				C	C		90814	17
2.9	<b>481.19</b>	0.18	589	0.9	0.17	510	B				C	C		70816	18
2.5	<b>561.76</b>	0.12	444	1.1	0.14	510	B				C	C		70814	19

The dynamic efficiency is 0.94 for all ratios

- Motor Flanges Available** Flange Motore Disponibili
- B) Supplied with Reduction Bushing** Fornito con Bussola di Riduzione
- B) Available on Request without reduction bushing** Disponibile a Richiesta senza Bussola di Riduzione
- C) Motor Flange Holes Position** Posizione Fori Flangia Motore

**EN** Unit FA53 is supplied with synthetic oil for lifetime lubrication, no maintenance is necessary. See table 1 for lubrication and recommended quantity. In table 2 please see possible radial loads and axial loads on the gearbox.

**I** Il riduttore FA53 viene fornito completo di olio sintetico per la lubrificazione permanente e non necessita di alcuna manutenzione. Vedi tab.1 per oli e quantità consigliati. In tab.2 sono presenti i carichi radiali e assiali applicabili al riduttore.

**D** Das Getriebe FA53 ist mit synthetischem Öl gefüllt und ist lebensdauer geschmiert. In Tabelle 1 ist die Schmiermenge und das empfohlene Schmiermittel angegeben. In Tabelle 2 sind die zulässigen Radial- und Axialbelastungen des Getriebes aufgeführt.

**F** Le réducteur FA53 est fourni complet avec de l'huile synthétique pour la lubrification permanente et ne nécessite aucun entretien. Voir tableau 1 concernant les huiles et les quantités conseillées. Les charges radiales et axiales applicables au réducteur sont précisées dans le tableau 2.

**E** El reductor tamaño FA53 se suministra, lubricado de por vida con aceite sintético y no requieren mantenimiento alguna. Ver tabla 1, para cantidades y aceites recomendados. En la tabla 2, se encuentran las cargas radiales y axiales admitidas por el reductor.

Standard supplied	For these mounting position specify in the order or add oil Per queste posizioni specificare in fase d'ordine o aggiungere olio				
2.15 LT	1.25 LT	1.25 LT	1.45 LT	2.35 LT	1.45 LT
AGIP Telium VSF 320			SHELL Omala S4 WE 320		

For all details on lubrication and plugs check our website **tab. 1**  
Per maggiori dettagli su lubrificazione e tappi olio vedi il nostro sito web

### RADIAL AND AXIAL LOADS

**Output shaft**  
Albero di uscita

$F_{eq} = FR \cdot \frac{149.5}{X+119.5}$

$n_2$	FA	FR	$n_2$	FA	FR	$n_2$	FA	FR
300	400	2000	140	460	2300	70	580	2900
250	420	2100	120	500	2500	40	780	3900
200	440	2200	85	550	2750	15	1140	5700

**On request reinforced bearings to increase loads.**  
A richiesta cuscinetti rinforzati per aumentare i carichi.

**Input shaft**  
Albero in entrata

$n_1$	FA	FR
1400	240	1200
900	280	1400
500	340	1700

tab. 2

**PFA53C...** Basic gearbox  
Riduttore base

Gearbox weight **15.5 kg**  
peso riduttore

M. flanges	Kit code	øF	A
63B5	K063.4.041	140	239
71B5	K063.4.042	160	237
80/90B5	K063.4.043	200	239
71B14	K063.4.047	105	237
80B14	K063.4.046	120	239
90B14	K063.4.041	140	239

● Available torque arms,  
see our web site  
Bracci di reazione disponibili,  
consulta il nostro sito web

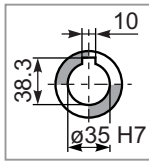

**Standard**  
Hollow shaft

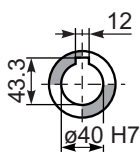

**On request**  
A richiesta

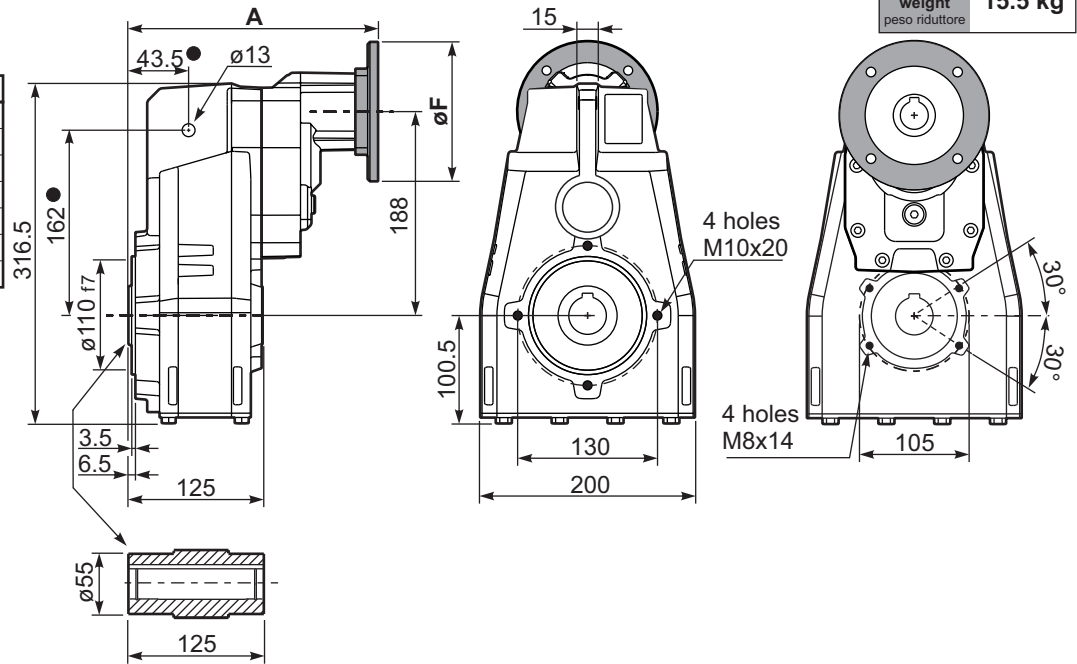

**PFA53...-F...** Output flange  
Flangia uscita

Motor Flange	k1
63B5	272
71B5	270
80/90B5	272
71B14	270
80B14	272
90B14	272

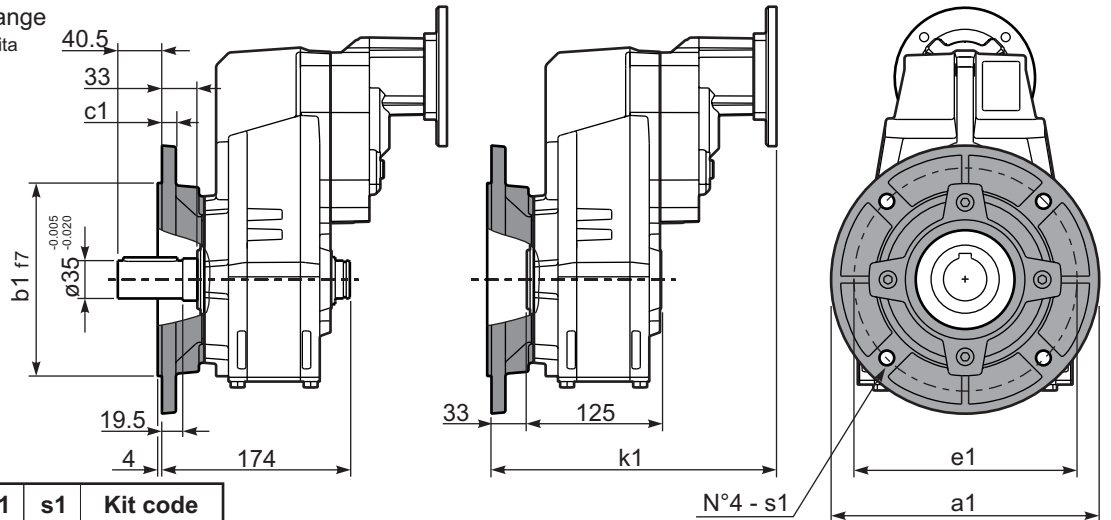

**Available output flanges**  
Flange di uscita

a1 ø	b1	c1	e1	s1	Kit code
250	180	13	215	14	KF60.9.011
300	230	16	265	14	KF60.9.012

**RFA53C...** Input Shaft  
Albero in entrata

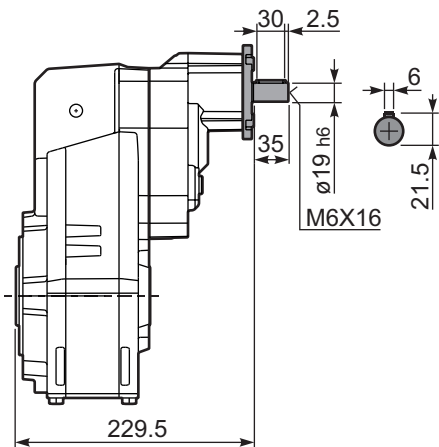

**PFA53 A...** Single output shaft  
Albero uscita semplice

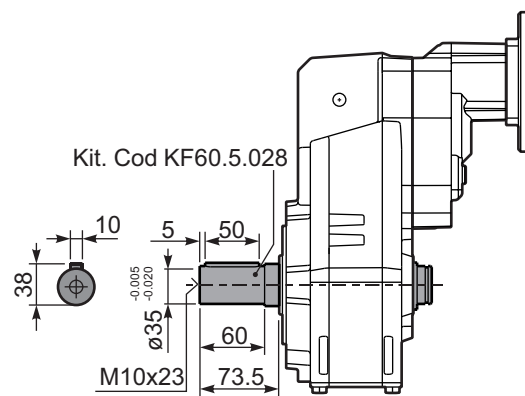

**PFA53D...** Shrink disk  
Calettatore

