

QUICK SELECTION / Selezione veloce

input speed (n_1) = 1400 min⁻¹

Output Speed n_2 [min ⁻¹]	Ratio i	Motor power P_{1M} [kW]	Output torque M_{2M} [Nm]	Service factor f.s.	Nominal power P_{1R} [kW]	Nominal torque M_{2R} [Nm]	Available B5 motor flanges		Available B14 motor flanges		Dynamic efficiency RD	Tooth Module [mm]	 Ratios code
							-A	-B	-O	-P			
							56	63	56	63			
5.6	252	0.18	142	1.6	0.29	230	B		B-C		46	2.7	01
3.9	360	0.18	181	1.3	0.23	230	B		B-C		41	2.7	02
2.6	540	0.12	164	1.4	0.17	230	B		B-C		37	2.7	03
1.9	720	0.12	200	1.1	0.14	230	B		B-C		34	2.7	04
1.3	1080	0.12	265	0.9	0.10	230	B		B-C		30	2.7	05
1.0	1440	0.12*	230	<0.8	0.09	230	B		B-C		27	2.7	06
0.5	2745	0.12*	230	<0.8	0.05	230	B		B-C		23	2.1	07

A) Motor Flanges Available
Flange Motore Disponibili

B) Supplied with Reduction Bushing
Fornito con Bussola di Riduzione

B) Available on Request without reduction bushing
Disponibile a Richiesta senza Bussola di Riduzione

C) Motor Flange Holes Position
Posizione Fori Flangia Motore

* Power higher than the maximum one which can be supported by the gearbox. Select according to the torque M_{2R}
Potenza superiore a quella massima sopportabile dal riduttore. Selezionare in base al momento torcente M_{2R}

EN Unit 633 is supplied with synthetic oil, providing "long life" lubrication. For mounting position V5-V6 please contact us. See table 1 for lubrication and recommended quantity. In table 2 please see possible radial loads and axial loads on the gearbox.

I Il riduttore tipo 633 viene fornito lubrificato a vita con olio sintetico. Per posizioni V5-V6 contattare il ns. servizio tecnico. Vedi tab.1 per oli e quantità consigliati. In tab.2 sono presenti i carichi radiali e assiali applicabili al riduttore.

D Für die Lebensdauerschmierung ist das Getriebe der Größe 633 mit synthetischem Öl befüllt. Bei Einbaulage V5 oder V6 bitten wir um Rücksprache. In Tabelle 1 ist die Schmiermenge und das empfohlene Schmiermittel angegeben. In Tabelle 2 sind die zulässigen Radial - und Axialbelastungen des Getriebes aufgeführt.

F Le réducteur de type 633 est fourni lubrifié à vie avec de l'huile synthétique. Concernant les positions V5.V6, contactez notre service d'assistance technique. Voir tableau 1 concernant les huiles et les quantités conseillées. Les charges radiales et axiales applicables au réducteur sont précisées dans le tableau 2.

E El reductor tamaño 633 se suministra, lubricado de por vida con aceite sintético. Para las posiciones V5 y V6 contactar con nuestro servicio técnico. Ver tabla 1, para cantidades y aceites recomendados. En la tabla 2, se encuentran las cargas radiales y axiales admitidas por el reductor.

LUBRICATION 633 Oil 0.40 Lt. 0.03 Lt.

Quantity 0.40/0.03 Lt.

AGIP Telium VSF 320	SHELL Omala S4 WE 320
----------------------------	------------------------------

For all details on lubrication and plugs check our website **tab. 1**
Per maggiori dettagli su lubrificazione e tappi olio vedi il nostro sito web

RADIAL AND AXIAL LOADS

Output shaft
Albero di uscita

n_2 [min ⁻¹]	FA [N]	FR [N]
25	700	3800
15	800	4000

Input shaft
albero in entrata

n_1 [min ⁻¹]	FA [N]	FR [N]
1400	20	100

*Strong axial loads in the DX direction are not allowed.
Non sono consentiti forti carichi assiali con direzione DX

tab. 2

3D dimensions on request

P633**FB**... Basic wormbox
Riduttore base

Gearbox weight
peso riduttore **7.50 kg**

M. flanges	Kit code	øF	A
56B5	K030.4.041	120	61.5
63B5	K030.4.042	140	62.5
56B14	K030.4.046	80	61.5
63B14	K030.4.045	90	62.5

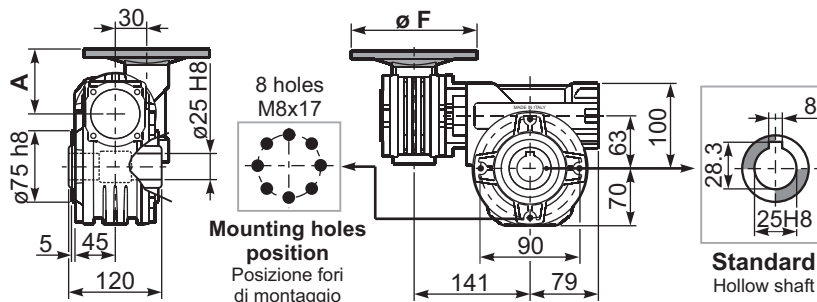

P633**PA**... Feet
Piedini

P633**PB**... Feet
Piedini

P633**PV**... Feet
Piedini

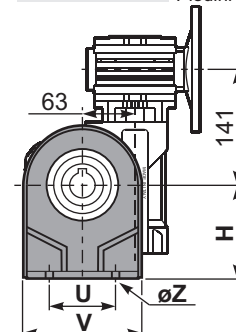
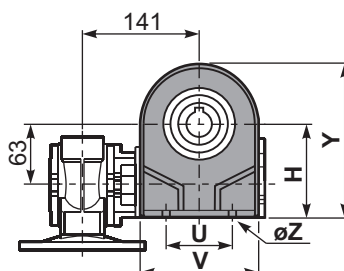
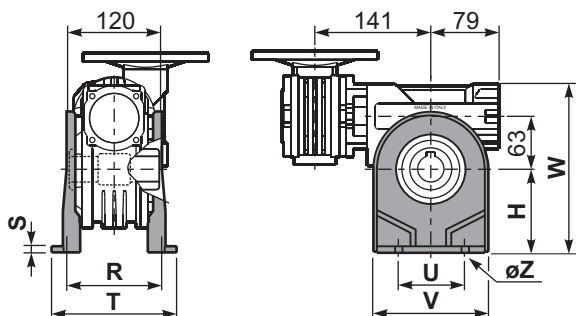

	H	R	S	T	U	V	Y	W	øZ	kit code
type B	100	111	4	144	95	133	170	200	ø10.5	K063.9.022
type S	-	-	-	-	-	-	-	-	-	-

P633**FC**... Output flange
Flangia uscita

P633**BR**... Reaction arm
Braccio di reazione

kit cod. K063.9.027

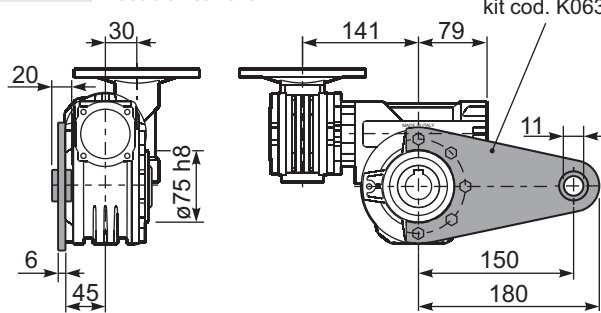
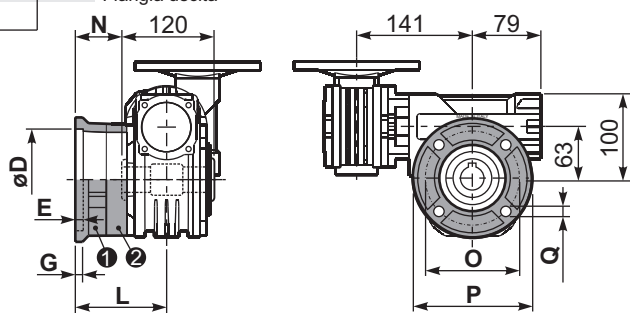

type B	øD	E	G	L	N	O	P	Q	kit code
FC	115 ^{+0.20} / _{+0.15}	7	13	86	26	150	175	11	1. K063.9.010 2. -
FL	115 ^{+0.20} / _{+0.15}	7	13	116	56	150	175	11	1. K063.9.010 2. K063.0.200
type S	øD	E	G	L	N	O	P	Q	kit code
F1	130 ^{+0.20} / _{+0.15}	7	13	102	42	165	200	13	1. KS070.9.013 2. -
F2	115 ^{+0.20} / _{+0.15}	7	13	116	56	150	175	11	1. KS063.9.013 2. -
F3	110 ^{+0.035} / ₀	5	11	82	22	130	160	10	1. KS063.9.011 2. -

P633.....**S**... Single Shaft
Albero lento semplice

P633.....**D**... Double Shaft
Albero lento bisp.

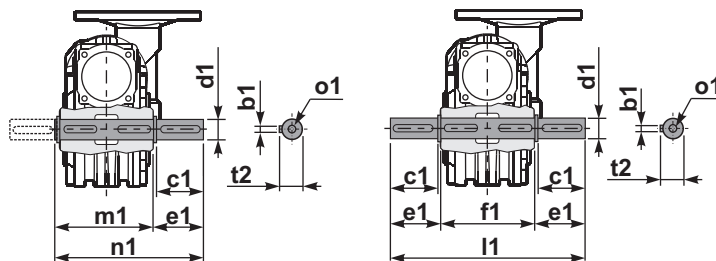

1 kit cod. K063.5.028 type B

2 kit cod. K063.5.029 type B

R633**FB**... Input shaft
Albero in entrata

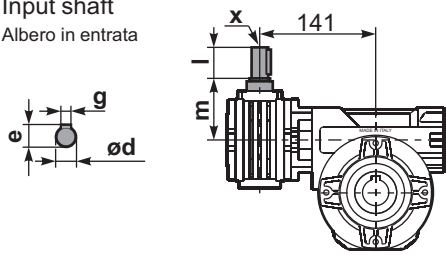

	ød	e	g	l	m	x	kit code
type B	9 h6	10.2	3	20	58	-	1. K030.5.006 PAM63 2. -
type S	-	-	-	-	-	-	1. - 2. -

	b1	c1	d1	e1	f1	l1	m1	n1	t2	o1
type B	8	60	25 ^{-0.005} / _{-0.020}	63.2	120	246.4	126.8	190	28	M8x20
type S	-	-	-	-	-	-	-	-	-	-