

# Compact

# Gears



Cat.: CT-RFX-FC-HM017

## Shaft mounted gearboxes

Riduttori ad assi paralleli  
0.06 ÷ 22kW



Made in Italy



Design according  
to SILVER 6.3.1  
standard



# HYDRO · MEC

# Aluminum & cast iron shaft mounted gearboxes

## A modular and compact product

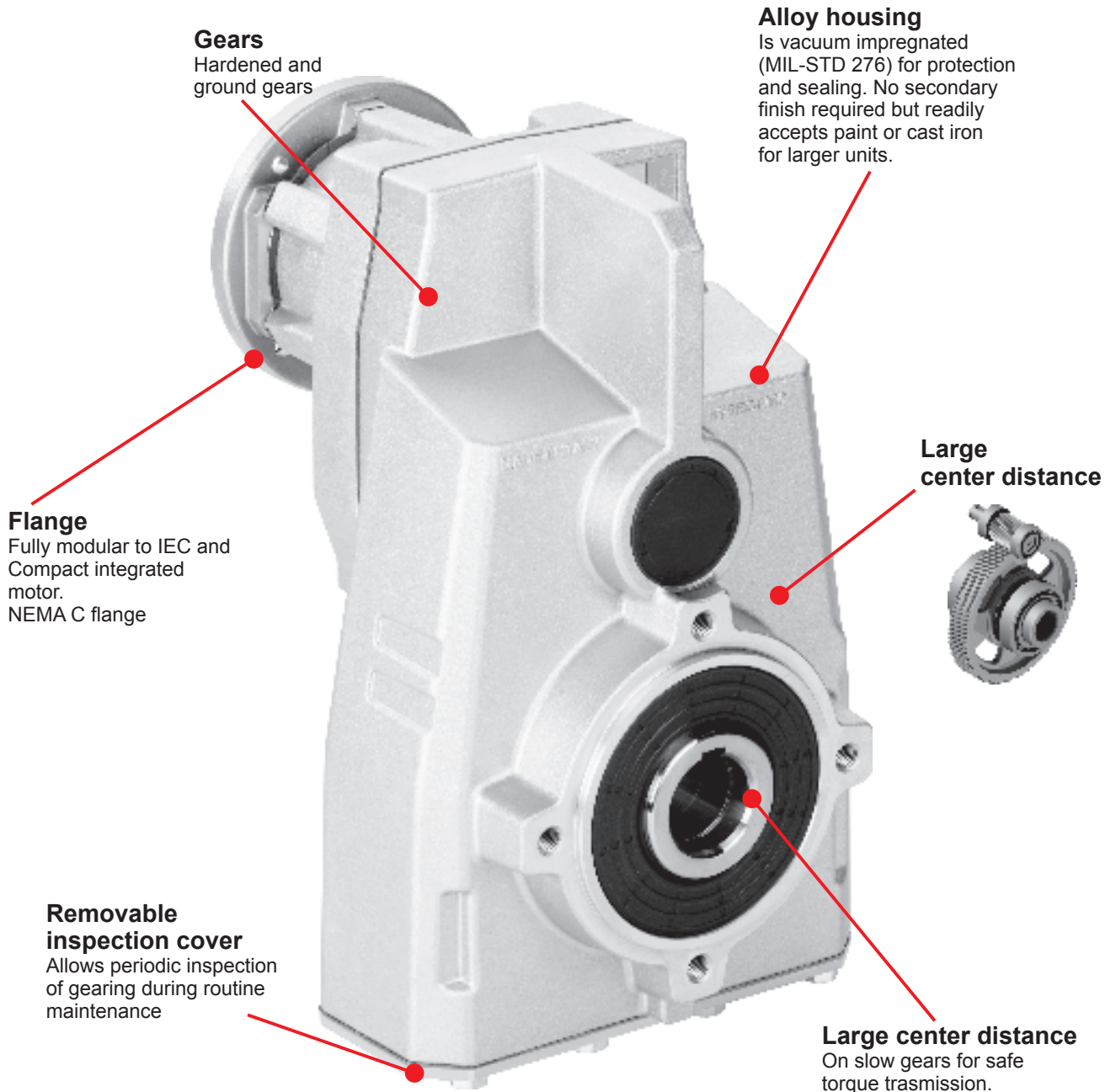

### Single-piece aluminum / Cast Iron housing

Combines light weight with high tensile strength. Precision machined for alignment of bearings and gearing

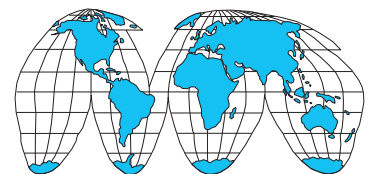
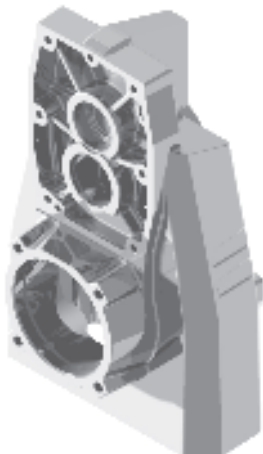

World wide sales network.

# Specific type datasheet on page...

On page / A pagina / Auf Seite / À la page / En la página

3 Stage

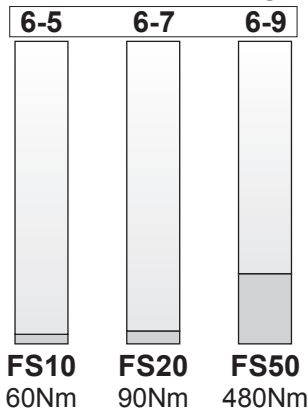

Types / Tipi /  
Tipen / Types /  
Tipos

On page / A pagina / Auf Seite / À la page / En la página

1 Stage

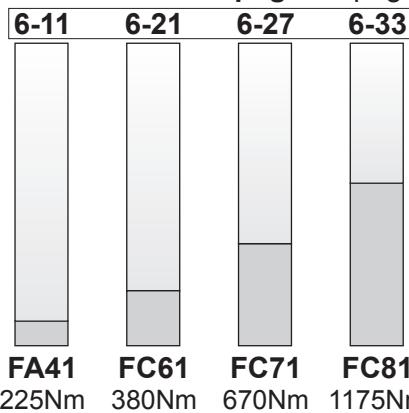

Types / Tipi /  
Tipen / Types /  
Tipos

On page / A pagina / Auf Seite / À la page / En la página

2 and 3 Stage

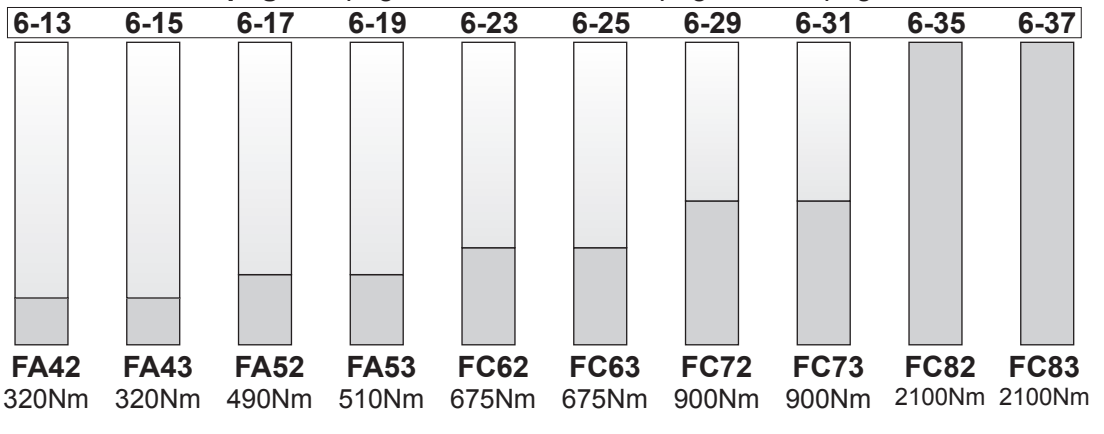

Types / Tipi /  
Tipen / Types /  
Tipos

On page / A pagina / Auf Seite / À la page / En la página

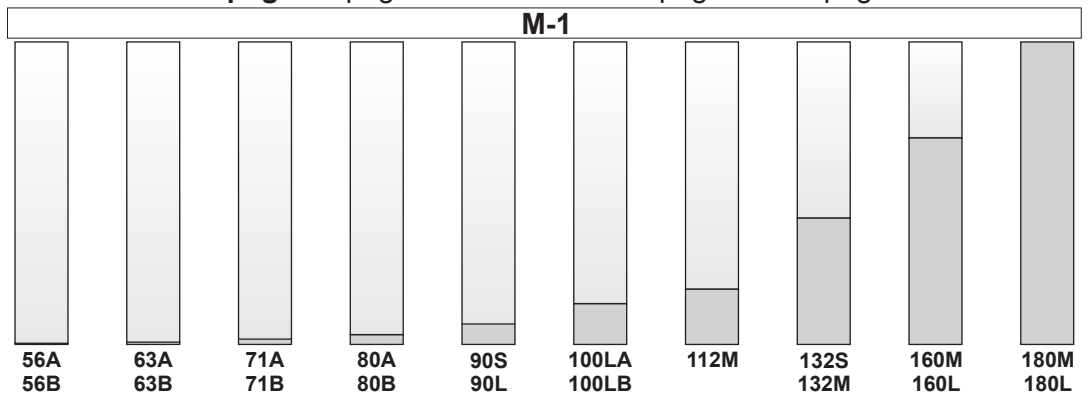

Types / Tipi /  
Tipen / Types /  
Tipos

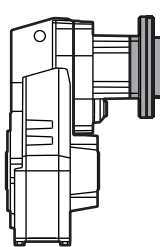
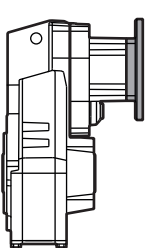
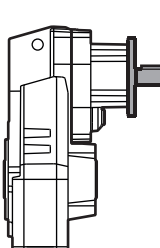
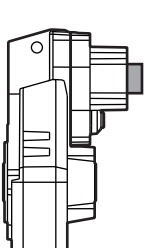
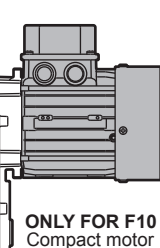
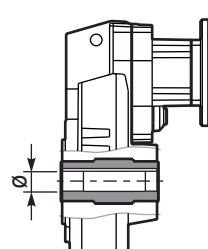
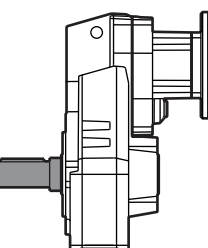
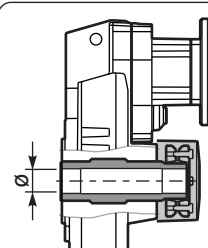
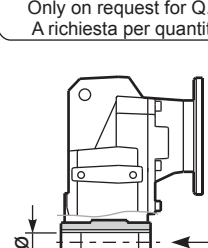
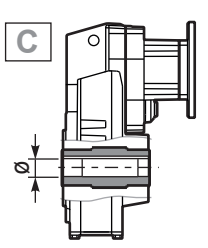
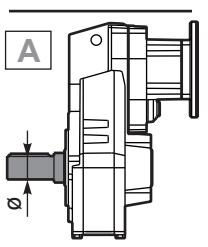
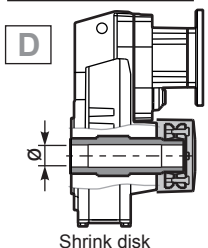





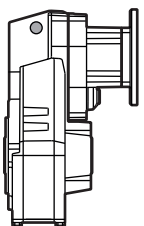
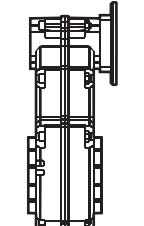
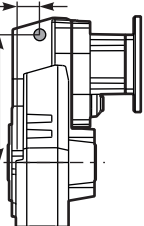
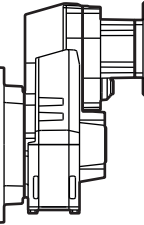
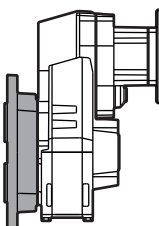

Type - Tipo - Typ Type - Tipo	Size - Grandezza - Grösse Taille - Tomaño	Mounting - Montaggio Montage - Fixation Tipo de montaje	Rapporto - Ratio Untersetzung Reduction - Relacion	Output shaft Albero uscita Abtriebswelle Arbre de sortie Eje en salida
<p><b>M</b></p> <p>Shaft mounted helical Riduttori ad assi paralleli</p>  <p>With IEC motor <b>M</b></p>  <p>With motor flange <b>P</b></p>  <p>With male input shaft <b>R</b></p>  <p>Modular base <b>B</b></p> <p>Not available for: FC61, FC71, FC81, FC82.</p>  <p>ONLY FOR F10 Compact motor</p> <p><b>C</b></p>	<p><b>FA42</b></p> <p>1 Stage Riduzione Stufe Trains Etapas</p> <p>2 Stages Riduzioni Stufen Trains Etapas</p> <p>3 Stages Riduzioni Stufen Trains Etapas</p> <p>Aluminum/Alluminio/Aluminium/Aluminio</p> <p><b>FA41</b></p> <p><b>FA42</b> <b>FA52</b></p> <p><b>FA43</b> <b>FA53</b></p> <p><b>FS10</b></p> <p><b>FS20</b></p> <p><b>FS50</b></p> <p>Cast Iron/Ghisa/Grauguss/Fonte/Fundicion</p> <p><b>FC61</b> <b>FC71</b> <b>FC81</b></p> <p><b>FC62</b> <b>FC72</b> <b>FC82</b></p> <p><b>FC63</b> <b>FC73</b> <b>FC83</b></p>	<p><b>C</b></p>  <p>Hollow output shaft <b>C</b></p>  <p>Single output shaft <b>A</b></p>  <p>Shrink Disk <b>D</b></p> <p>Only on request for Q.ty A richiesta per quantità</p>  <p>Stainless steel hub <b>I</b></p> <p>On request for q.ty</p> <p>Stainless steel hub Mozzo in acciaio Inox Edelstahlhohlwelle Moyeu en acier Inox Nucleo corona de acero Inox</p>	<p><b>10.04</b></p> <p>See technical data table</p> <p>Vedi tabelle dati tecnici.</p> <p>Technisches Datenblatt beachten</p> <p>Voir Tableau données techniques</p> <p>Ver tabla datos técnicos</p>	<p><b>-D</b></p>  <p><b>C</b></p> <p>→ <b>STANDARD</b> → Only on request for Q.ty A richiesta per quantità</p> <p><b>FS10</b></p> <p><b>-J</b> → <math>\varnothing 17</math></p> <p><b>FS20</b></p> <p><b>-B</b> → <math>\varnothing 20</math></p> <p><b>FA41 FA42 FA43</b></p> <p><b>-C</b> → <math>\varnothing 25</math></p> <p><b>FA41 FA42 FA43 FS50</b></p> <p><b>-D</b> → <math>\varnothing 30</math></p> <p><b>-E</b> → <math>\varnothing 35</math></p> <p><b>FA52 FA53 FC61 FC62 FC63</b></p> <p><b>-E</b> → <math>\varnothing 35</math></p> <p><b>-F</b> → <math>\varnothing 40</math></p> <p><b>FC71 FC72 FC73</b></p> <p><b>-F</b> → <math>\varnothing 40</math></p> <p><b>-G</b> → <math>\varnothing 45</math></p> <p><b>FC81 FC82 FC83</b></p> <p><b>-H</b> → <math>\varnothing 50</math></p> <p><b>-I</b> → <math>\varnothing 55</math></p>  <p>Single output shaft</p> <p><b>-M</b> FA41/2/3 → <math>\varnothing 30</math></p> <p><b>-N</b> FA52/3 FC61/2/3 → <math>\varnothing 35</math></p> <p><b>-O</b> FC71/2/3 → <math>\varnothing 40</math></p> <p><b>-K</b> FC81/2/3 → <math>\varnothing 50</math></p>  <p>Shrink disk</p> <p><b>-Q</b> FA42/3 → <math>\varnothing 30</math></p> <p><b>-T</b> FA52/3 FC62/3 → <math>\varnothing 35</math></p> <p><b>-U</b> FC72/3 → <math>\varnothing 40</math></p> <p><b>-V</b> FC82/3 → <math>\varnothing 50</math></p>

6



On request we can deliver our products according to the ATEX  
 A richiesta possiamo fornire i nostri prodotti secondo le normative ATEX  
 Auf Anfrage können wir unsere Produkte den Richtlinien ATEX entsprechend liefern  
 Sur demande nos produits peuvent se conformer à la réglementation ATEX  
 A pedido, se pueden enviar nuestros productos de acuerdo con las normas ATEX.

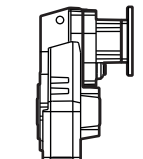
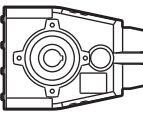
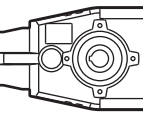
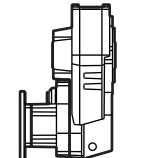
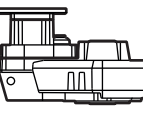
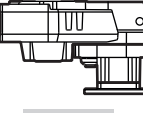
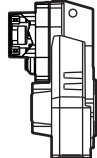
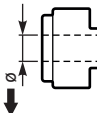

Type - Tipo - Typ Types - Tipo	Output flange Flangia uscita Ausgangsflansch Bride de sortie Brida en salida	Motor size - Grandezza motore Motor Grösse Grandeur moteur - Tamaño motor	Terminal box position Posizione morsetti Klemmkastenlage Position boîte à bornes Posición caja de bornes	Mounting position Posizione montaggio Einbaulage Position de montage Posición de montaje	Coupling Giunto Kupplung Joint Juntura
<p><b>ST</b></p>  <p><b>ST</b> Foro standard Standard bore</p>  <p><b>ST</b> only for FS10 / FS20 Senza braccio di reazione Without reaction arm</p>  <p>Available torque arms, see our web site. Bracci di reazione disponibili, vedi il nostro sito web.</p> <p><b>S..</b></p>  <p><b>-F</b> Whit output flange con flangia uscita</p>	<p><b>N</b></p>  <p><b>N</b> Senza flangia Without flange</p> <p>FS20</p> <p><b>1</b> → <b>∅140</b></p> <p>FA41 FA42 FA43</p> <p><b>2</b> → <b>∅160</b></p> <p><b>3</b> → <b>∅200</b></p> <p><b>4</b> → <b>∅250</b></p> <p>FA52 FA53 FC61 FC62 FC63</p> <p><b>4</b> → <b>∅250</b></p> <p><b>5</b> → <b>∅300</b></p> <p>FC71 FC72 FC73</p> <p><b>4</b> → <b>∅250</b></p> <p><b>5</b> → <b>∅300</b></p> <p><b>6</b> → <b>∅350</b></p> <p>FC81 FC82 FC83</p> <p><b>5</b> → <b>∅300</b></p> <p><b>6</b> → <b>∅350</b></p> <p><b>7</b> → <b>∅400</b></p>	<p><b>-C</b></p> <p>Flange Flangia</p>  <p><b>B5</b></p> <p><b>-A</b>=56 (∅120)</p> <p><b>-B</b>=63 (∅140)</p> <p><b>-C</b>=71 (∅160)</p> <p><b>-D</b>=80 (∅200)</p> <p><b>-E</b>=90 (∅200)</p> <p><b>-F</b>=100+112 (∅250)</p> <p><b>-G</b>=132 (∅300)</p> <p><b>-H</b>=160 (∅350)</p> <p><b>-I</b>=180 (∅350)</p> <p><b>B14</b></p> <p><b>-O</b>=56 (∅80)</p> <p><b>-P</b>=63 (∅90)</p> <p><b>-Q</b>=71 (∅105)</p> <p><b>-R</b>=80 (∅120)</p> <p><b>-T</b>=90 (∅140)</p> <p><b>-U</b>=100+112 (∅160)</p> <p><b>-V</b>=132 (∅200)</p> <p><b>COMPACT</b></p> <p><b>CZ</b> = 56</p> <p><b>C0</b> = 63</p> <p>Type R Tipo R</p>  <p>FA43 FS10 FS20 FS50</p> <p><b>-1</b> → <b>∅14</b></p> <p>FA42 FA53 FC63 FC73</p> <p><b>-2</b> → <b>∅19</b></p> <p>FA52 FC62 FC72 FC83</p> <p><b>-3</b> → <b>∅24</b></p> <p>FC82</p> <p><b>-4</b> → <b>∅28</b></p> <p>Without flange Senza flangia</p>  <p><b>-M</b> → With coupling</p> <p>FA43 FS10 FS20 FS50</p> <p><b>-Z</b> → <b>∅9</b> (56B5)</p> <p><b>-0</b> → <b>∅11</b> (63B5)</p> <p><b>-1</b> → <b>∅14</b> (71B5)</p> <p>FA42 FA53 FC63 FC73</p> <p><b>-1</b> → <b>∅14</b> (71B5)</p> <p><b>-2</b> → <b>∅19</b> (80B5)</p> <p><b>-2</b> → <b>∅19</b> (80B5)</p> <p><b>-3</b> → <b>∅24</b> (90B5)</p> <p><b>-3</b> → <b>∅24</b> (90B5)</p> <p><b>-4</b> → <b>∅28</b> (100B5)</p> <p>FA52 FC62 FC72 FC83</p> <p><b>-2</b> → <b>∅19</b> (80B5)</p> <p><b>-3</b> → <b>∅24</b> (90B5)</p> <p><b>-4</b> → <b>∅28</b> (100B5)</p> <p>FA41</p> <p><b>-4</b> → <b>∅28</b> (100B5)</p>	<p><b>B</b></p>  <p><b>A</b></p>  <p><b>B</b></p> <p>STANDARD</p>  <p><b>C</b></p>  <p><b>D</b></p>	<p><b>H1</b></p>  <p><b>H1</b> STANDARD</p>  <p><b>H4</b></p>  <p><b>H3</b></p>  <p><b>H2</b></p>  <p><b>H5</b></p>  <p><b>H6</b></p>	<p><b>0</b></p> <p>Without coupling Senza giunto</p>  <p><b>-</b></p> <p>Nothing indication: standard bore</p> <p>Nessuna indicazione: foro standard</p> <p>COUPLING</p>  <p><b>A</b> = 9mm</p> <p><b>B</b> = 11mm</p> <p><b>C</b> = 14mm</p> <p><b>D</b> = 19mm</p> <p><b>E</b> = 24mm</p> <p><b>F</b> = 28mm</p>

POTENZA RICHIESTA / REQUIRED POWER / ERFORDERLICHE LEISTUNG / PUISSANCE NECESSAIRE / POTENCIA NECESARIA

Lifting / sollevamento / hubantriebe / levage / elevación

$$P \text{ [KW]} = \frac{M \text{ [Kg]} \cdot g \text{ [9.81]} \cdot v \text{ [m / s]}}{1000}$$

Rotation / rotazione / drehung / rotation / rotacion

$$P \text{ [KW]} = \frac{M \text{ [Nm]} \cdot n \text{ [rpm]}}{9550}$$

Linear movement / traslazione / linearbewegung / translation / translacion

$$P \text{ [KW]} = \frac{F \text{ [N]} \cdot v \text{ [m / s]}}{1000}$$

TORQUE / COPPIA / DREHMOMENT / COUPLE / PAR

$$M \text{ [Nm]} = \frac{9550 \cdot P \text{ [KW]}}{n \text{ [rpm]}}$$

$$M \text{ [lb in]} = \frac{63030 \cdot P \text{ [HP]}}{n \text{ [rpm]}}$$

RADIAL LOADS / CARICHI RADIALI / RADIALE - UND AXIALLASTEN / CHARGES RADIALES / CARGA RADIAL Y AXIAL

- Radial load generated by external transmissions keyed onto input and/or output shafts.
- Forza radiale generata da organi di trasmissione calettati sugli alberi di ingresso e/o uscita.
- Belastungen der Antriebs- bzw. Abtriebswellen durch von aussen eingebrachte Radiallasten.
- Charge radiale générée par la transmissions calés sur les entrées et / ou des arbres de sortie
- Cargas radiales, generada por transmisiones externas, aplicadas sobre los ejes de entrada y/o salida

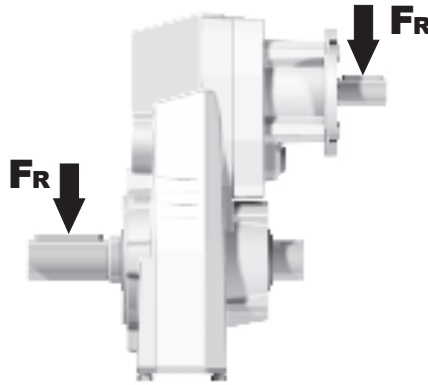

	$F_R \text{ [N]} = \frac{M \text{ [Nm]} \cdot 2000}{d \text{ [mm]}} \cdot f_k$	$F_R \text{ [N]} = \frac{M \text{ [lb in]} \cdot 8.9}{d \text{ [in]}} \cdot f_k$
<b>M</b>	Momento torcente / Output torque / Abtriebsdrehmoment / Couple / Par torsion	
<b>d</b>	Diametro primitivo / Diam. of driving element / Durchmesser der Abtriebseinheit / Diamètre primitif / Diámetro primitivo	
<b>f<sub>k</sub></b>	Coefficiente di trasformazione / Factor / Faktor / Coefficient de transmission / Coeficiente de transmisión <b>1.15</b> Ingranaggi / Gearwheels / Zahnrad / Engrenage / Engranaje <b>1.25</b> Catena / Chain sprockets / Antriebskette / Chaîne / Cadena <b>1.75</b> Cinghia Trapezoidale / Narrow v-belt pulley / Keilriemen / Courroie trap. / Correa trapezoidal <b>2.50</b> Cinghia piatta / Flat-belt pulley / Flachzahnriem. / Courroie crantée / Correa plana	

- If your application requires higher radial loads, contact our technical office. Higher load may be possible.
- Nel caso la vostra applicazione richieda carichi radiali superiori consultare il nostro ufficio tecnico, valori maggiori possono essere accettati.
- Wenn Ihre Anwendung höhere Radialbelastungen erfordert, so wenden Sie sich bitte an unser technischen Büro.
- Si votre application demande des charges radiales supérieures, s'adresser à notre bureau technique.
- En el caso en que una aplicación exija una carga radial superior a la especificada en el catálogo, consultar a nuestra oficinas técnica.

How to select a gearbox / Come selezionare un riduttore / Wie wählt man ein Getriebe  
Comment sélectionner un réducteur / Cómo seleccionar un reductor

**B** Output speed  
Velocità in uscita  
Abtriebsdrehzahl  
Vitesse de sortie  
Velocidad de salida

Nominal power  
Potenza nominale  
Max. mögliche Leistung  
Poissance nominale  
Potencia nominal

Gear size  
Grandezza riduttore  
Getriebegröße  
Taille réducteur  
Tamaño reductor

Motor power  
Potenza motore  
Motorleistung  
Puissance moteur  
Potencia motor

**A** Nominal torque  
Momento torcente nominale  
Nenn Drehmoment  
Couple nominal  
Par de torsión nominal

Flange code  
Codice flangia  
Flanschtype  
Code bride  
Código bridas

Input speed  
Velocità in entrata  
Eintriebsdrehzahl  
Vitesse en entrée  
Velocidad de entrada

# FA42 Compact-Gear

## 320Nm

Rating - Aluminum  
SHAFT MOUNTED HELICAL

**QUICK SELECTION / Selezione veloce** input speed ( $n_1$ ) = 1400 min<sup>-1</sup>

Output Speed $n_2$ [min <sup>-1</sup> ]	Ratio $i$	Motor power $P_{1M}$ [kW]	Output torque $M_{2M}$ [Nm]	Service factor f.s.	Nominal power $P_{1R}$ [kW]	Nominal torque $M_{2R}$ [Nm]	Available B5 motor flanges					Available B14 motor flanges				Output Shaft 	Ratios code 
							-B	-C	-D	-E	-F	-Q	-R	-T	-U		
167	<b>8.38</b>	4	215	1.0	4.1	225	B					C	C			2821	01
139	<b>10.04</b>	3	194	1.2	3.7	240	B					C	C			2818	02
114	<b>12.33</b>	3	238	1.1	3.2	260	B					C	C			2813	03
92	<b>15.16</b>	2.2	216	1.2	2.6	260	B					C	C			1921	04

**C** Ratio  
Rapporto  
Untersetzung  
Rapport de réduction  
Relación

Transmitted torque  
Momento torcente trasmesso  
Mögliche Drehmomente  
Couple de sortie  
Par transmitido

Service factor  
Fattore di servizio  
Betriebsfaktor  
Facteur de service  
Factor de servicio

Output shaft diam.  
Diam. albero uscita  
Durchmesser abtriebswelle  
Diametre arbre lent  
Diametro eje de salida

Notes  
Note  
Anmerkungen  
Note  
Notas

**fs**

Type of load and starts per hour Tipo di carico e avviamenti per ora		Oper. hours per day Ore di funz. giorn.		
		3 h	10 h	24 h
Continuous or intermittent appl. with start / hour Applicazione cont. o interm. con n.ro operazioni/ora	Uniform / Uniforme	0.8	1	1.25
	Moderate / Moderato	1	1.25	1.5
	Heavy / Forte	1.25	1.5	1.75
Intermittent application with start / hour Applicazione intermittente con n.ro operazioni/ora	Uniform / Uniforme	1	1.25	1.5
	Moderate / Moderato	1.25	1.5	1.75
	Heavy / Forte	1.5	1.75	2.15

**D** Motor flange available  
Flange disponibili  
Erhältliche Motorflansche  
Brides disponibles  
Bridas disponibles

<b>B)</b>	Mounting with reduction ring Montaggio con boccia di riduzione Reduzierhülsen Montage avec douille de réduction Montaje con casquillo de reducción	
<b>C)</b>	Motor flangeholes position/terminal box position Posizione fori flangia/basetta motore Bohrungsposition am Motorflansch/-socket Position trous bride/barrette à bornes moteur Posición agujeros brida / base motor	
<b>B)</b>	Available without reduction bushes Disponibile anche senza boccia Auch ohne Reduzierbuchse verfügbar Disponible aussi sans douille de réduction Disponible tambien sin casquillo	

<b>A</b>	Select required torque (according to service factor)	Seleziona la coppia desiderata (comprensiva del fattore di servizio)	Max. Drehmoment in Bezug zum Betriebsfaktor	Sélectionner le couple souhaité (comprenant le facteur de service)	Seleccionar el par deseado (incluyendo el factor de servicio)
<b>B</b>	Select output speed	Seleziona la velocità in uscita	Ausgewählte Abtriebsdrehzahl	Sélectionner la vitesse de sortie	Seleccionar la velocidad de salida
<b>C</b>	On the same line of selected geared motor, you can find the gear ratio	Sulla riga corrispondente alla motorizzazione prescelta si può rilevare il rapporto di riduzione	Auf der gleichen Linie wie die ausgewählte Motorleistung steht auch die Getriebeuntersetzung	Sur la ligne correspondante à la motorisation pré-choisie on peut relever le rapport de réduction	En la línea correspondiente al motor preseleccionado es posible encontrar la relación de reducción
<b>D</b>	Select motor flange available (if requested)	Scegli la flangia disponibile (se richiesta)	Erhältliche Motorflansche (auf Anfrage)	Choisir la bride disponible (si elle est demandée)	Seleccionar la brida disponible (sobre pedido)



### QUICK SELECTION / Selezione veloce

input speed ( $n_1$ ) = 1400 min<sup>-1</sup>

Output Speed $n_2$ [min <sup>-1</sup> ]	Ratio $i$	Motor power $P_{1M}$ [kW]	Output torque $M_{2M}$ [Nm]	Service factor f.s.	Nominal power $P_{1R}$ [kW]	Nominal torque $M_{2R}$ [Nm]	Available B5 motor flanges		Available B14 motor flanges			Hollow Shaft  Ø	Ratios code 
							-B	-C	-O	-P	-Q		
							63	71	56	63	71		
72	<b>19.42</b>	0.37	46	1.3	<b>0.48</b>	<b>60</b>			C	C		281713	01
51	<b>27.21</b>	0.37	65	0.9	<b>0.34</b>	<b>60</b>			C	C		281313	02
36.4	<b>38.49</b>	0.25	62	1.0	<b>0.24</b>	<b>60</b>			C	C		191713	03
31.7	<b>44.12</b>	0.18	54	1.1	<b>0.21</b>	<b>60</b>			C	C		171713	04
26.7	<b>52.50</b>	0.18	64	0.9	<b>0.18</b>	<b>60</b>			C	C		151713	05
22.6	<b>61.82</b>	0.12	49	1.2	<b>0.15</b>	<b>60</b>			C	C		171313	06
19.0	<b>73.56</b>	0.12	58	1.0	<b>0.13</b>	<b>60</b>			C	C		151313	07
15.9	<b>88.13</b>	0.09	56	1.1	<b>0.11</b>	<b>60</b>			C	C		101713	08
12.0	<b>116.67</b>	0.06	48	1.2	<b>0.08</b>	<b>60</b>			C	C		91713	09
11.3	<b>123.48</b>	0.06	51	1.2	<b>0.08</b>	<b>60</b>			C	C		101313	10
9.0	<b>155.37</b>	0.06	64	0.9	<b>0.06</b>	<b>60</b>			C	C		71713	11
8.6	<b>163.47</b>	0.06	68	0.9	<b>0.06</b>	<b>60</b>			C	C		91313	12
7.6	<b>184.39</b>	0.06	76	0.8	<b>0.05</b>	<b>60</b>			C	C		61713	13
6.4	<b>217.68</b>	0.06*	90	0.7	<b>0.04</b>	<b>60</b>			C	C		71313	14
5.4	<b>258.34</b>	0.06*	107	0.6	<b>0.04</b>	<b>60</b>			C	C		61313	15

The dynamic efficiency is **0.94** for all ratios \* Power higher than the maximum one which can be supported by the gearbox. Select according to the torque  $M_{2R}$   
Potenza superiore a quella massima sopportabile dal riduttore. Selezionare in base al momento torcente  $M_{2R}$

**A) Motor Flanges Available**  
Flange Motore Disponibili

**B) Supplied with Reduction Bushing**  
Fornito con Bussola di Riduzione

**B) Available on Request without reduction bushing**  
Disponibile a Richiesta senza Bussola di Riduzione

**C) Motor Flange Holes Position**  
Posizione Fori Flangia Motore

**EN** Unit **FS10** is supplied with synthetic oil for lifetime lubrication, no maintenance is necessary. See table 1 for lubrication and recommended quantity. In table 2 please see possible radial loads and axial loads on the gearbox.

**I** Il riduttore **FS10** viene fornito completo di olio sintetico per la lubrificazione permanente e non necessita di alcuna manutenzione. Vedi tab.1 per oli e quantità consigliati. In tab.2 sono presenti i carichi radiali e assiali applicabili al riduttore.

**D** Das Getriebe **FS10** ist mit synthetischem Öl gefüllt und ist lebensdauergeschmiert. In Tabelle 1 ist die Schmiermenge und das empfohlene Schmiermittel angegeben. In Tabelle 2 sind die zulässigen Radial- und Axialbelastungen des Getriebes aufgeführt.

**F** Le réducteur **FS10** est fourni complet avec de l'huile synthétique pour la lubrification permanente et ne nécessite aucun entretien. Voir tableau 1 concernant les huiles et les quantités conseillées. Les charges radiales et axiales applicables au réducteur sont précisées dans le tableau 2.

**E** El reductor tamaño **FS10** se suministra, lubricado de por vida con aceite sintético y no requieren mantenimiento alguna. Ver tabla 1, para cantidades y aceites recomendados. En la tabla 2, se encuentran las cargas radiales y axiales admitidas por el reductor.

### LUBRICATION FS10 Oil Quantity 0.35 Lt.

**AGIP** Telium VSF 320

**SHELL** Omala S4 WE 320

For all details on lubrication and plugs check our website **tab. 1**  
Per maggiori dettagli su lubrificazione e tappi olio vedi il nostro sito web

### RADIAL LOADS

Input shaft  
Albero in entrata



$n_1$	FA	FR
1400	140	700
900	160	800

\*Strong axial loads in the DX direction are not allowed.  
Non sono consentiti forti carichi assiali con direzione DX

**tab. 2**



**PFS10...** Basic gearbox  
Riduttore base

Gearbox weight  
peso riduttore **3.1 kg**

**RFS10...** Input Shaft  
Albero in entrata

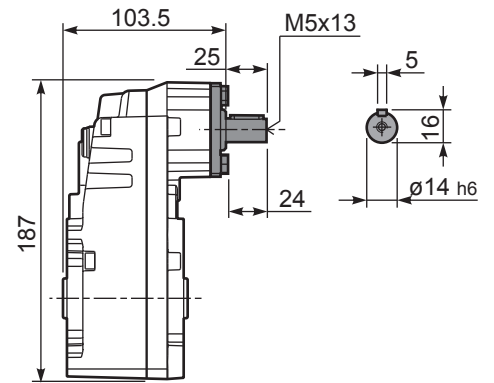
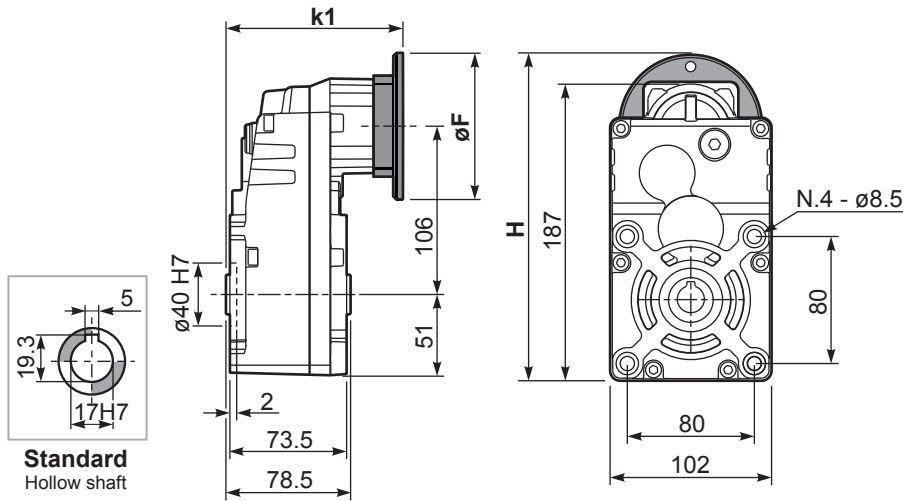

B14 Motor Flanges	H	øF	k1	kit code
56 B14	197	80	109.3	KC40.4.049
63 B14	202	90	111.8	K050.4.047
71 B14	209.5	105	109.3	K050.4.045

B5 Motor Flanges	H	øF	k1	kit code
63 B5	226	138	111.8	K050.4.041
71 B5	237	160	109.3	K050.4.042

### Available with integrated motor

Disponibile con motore integrato

Motor sizes available :  
Grandezza motore disponibile:

- 56 IEC
- 63 IEC

For more information, contact us.  
Per maggiori informazioni, contattaci.

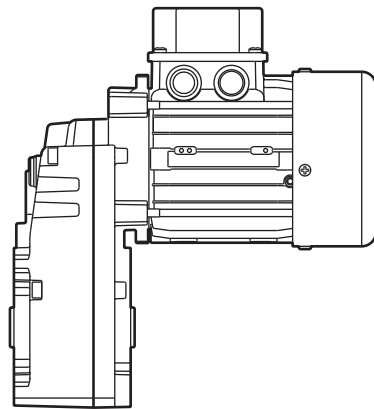



### QUICK SELECTION / Selezione veloce

input speed ( $n_1$ ) = 1400 min<sup>-1</sup>

Output Speed $n_2$ [min <sup>-1</sup> ]	Ratio $i$	Motor power $P_{1M}$ [kW]	Output torque $M_{2M}$ [Nm]	Service factor f.s.	Nominal power $P_{1R}$ [kW]	Nominal torque $M_{2R}$ [Nm]	Available B5 motor flanges		Available B14 motor flanges			Hollow Shaft  Ø	Ratios code 
							-B	-C	-O	-P	-Q		
24.2	<b>57.95</b>	0.25	93	1.0	<b>0.24</b>	<b>90</b>			C	C		2844	01
13.4	<b>104.80</b>	0.12	83	1.1	<b>0.13</b>	<b>90</b>			C	C		1954	02
11.5	<b>121.47</b>	0.12	96	0.9	<b>0.12</b>	<b>90</b>			C	C		1756	03
9.8	<b>142.59</b>	0.09	90	1.0	<b>0.10</b>	<b>90</b>			C	C		1558	04
8.2	<b>170.20</b>	0.06	70	1.3	<b>0.08</b>	<b>90</b>			C	C		1360	05
6.0	<b>232.32</b>	0.06	96	0.9	<b>0.06</b>	<b>90</b>			C	C		1063	06
4.6	<b>303.20</b>	0.06*	126	0.7	<b>0.05</b>	<b>90</b>			C	C		974	07
3.5	<b>400.37</b>	0.06*	166	0.5	<b>0.04</b>	<b>90</b>			C	C		776	08

The dynamic efficiency is **0.94** for all ratios \* Power higher than the maximum one which can be supported by the gearbox. Select according to the torque  $M_{2R}$   
Potenza superiore a quella massima sopportabile dal riduttore. Selezionare in base al momento torcente  $M_{2R}$

**A) Motor Flanges Available**  
Flange Motore Disponibili

**B) Supplied with Reduction Bushing**  
Fornito con Bussola di Riduzione

**B) Available on Request without reduction bushing**  
Disponibile a Richiesta senza Bussola di Riduzione

**C) Motor Flange Holes Position**  
Posizione Fori Flangia Motore

**EN** Unit **FS20** is supplied with synthetic oil for lifetime lubrication, no maintenance is necessary. See table 1 for lubrication and recommended quantity. In table 2 please see possible radial loads and axial loads on the gearbox.

**I** Il riduttore **FS20** viene fornito completo di olio sintetico per la lubrificazione permanente e non necessita di alcuna manutenzione. Vedi tab.1 per oli e quantità consigliati. In tab.2 sono presenti i carichi radiali e assiali applicabili al riduttore.

**D** Das Getriebe **FS20** ist mit synthetischem Öl gefüllt und ist lebensdauergeschmiert. In Tabelle 1 ist die Schmiermenge und das empfohlene Schmiermittel angegeben. In Tabelle 2 sind die zulässigen Radial- und Axialbelastungen des Getriebes aufgeführt.

**F** Le réducteur **FS20** est fourni complet avec de l'huile synthétique pour la lubrification permanente et ne nécessite aucun entretien. Voir tableau 1 concernant les huiles et les quantités conseillées. Les charges radiales et axiales applicables au réducteur sont précisées dans le tableau 2.

**E** El reductor tamaño **FS20** se suministra, lubricado de por vida con aceite sintético y no requieren mantenimiento alguna. Ver tabla 1, para cantidades y aceites recomendados. En la tabla 2, se encuentran las cargas radiales y axiales admitidas por el reductor.

### LUBRICATION FS20 Oil Quantity 0.50 Lt.

**AGIP** Telium VSF 320

**SHELL** Omala S4 WE 320

For all details on lubrication and plugs check our website **tab. 1**  
Per maggiori dettagli su lubrificazione e tappi olio vedi il nostro sito web

### RADIAL LOADS

**Input shaft**  
Albero in entrata

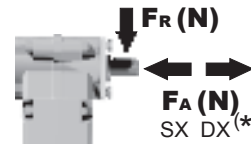

$n_1$	FA	FR
1400	140	700
900	160	800

**\*Strong axial loads in the DX direction are not allowed.**  
Non sono consentiti forti carichi assiali con direzione DX

**tab. 2**

**PFS20...** Basic gearbox  
Riduttore base

Gearbox weight  
peso riduttore **4.3 kg**

**RFS20...** Input Shaft  
Albero in entrata

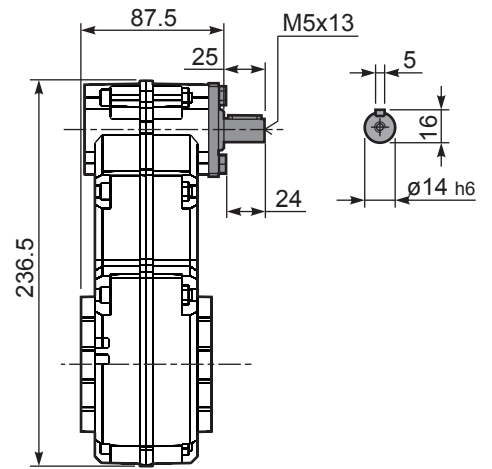
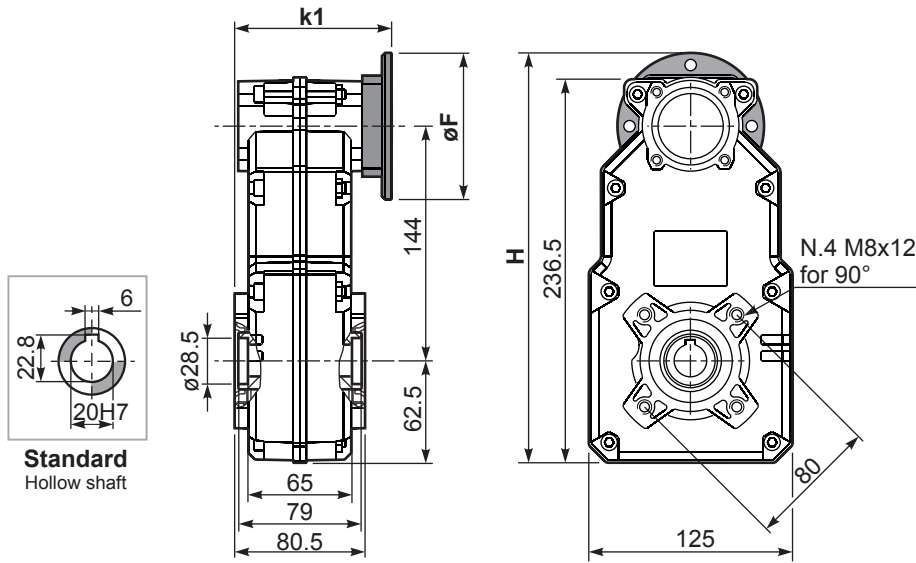

B14 Motor Flanges	H	$\phi F$	k1	kit code
56 B14	246.5	80	94.3	KC40.4.049
63 B14	251.5	90	96.8	K050.4.047
71 B14	259	105	94.3	K050.4.045

B5 Motor Flanges	H	$\phi F$	k1	kit code
63 B5	275.5	138	96.8	K050.4.041
71 B5	286.5	160	94.3	K050.4.042

**PFS20-F** Output flange  
flangia di uscita

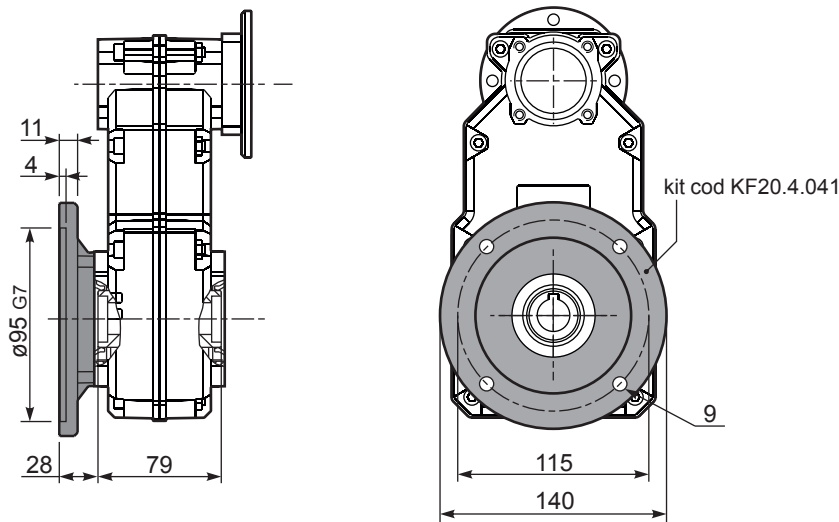



QUICK SELECTION / Selezione veloce							input speed (n <sub>1</sub> ) = 1400 min <sup>-1</sup>							
Output Speed n <sub>2</sub> [min <sup>-1</sup> ]	Ratio i	Motor power P <sub>1M</sub> [kW]	Output torque M <sub>2M</sub> [Nm]	Service factor f.s.	Nominal power P <sub>1R</sub> [kW]	Nominal torque M <sub>2R</sub> [Nm]	Available B5 motor flanges		Available B14 motor flanges			Output Shaft  Ratios code		
							-B	-C	-O	-P	-Q			
29.3	<b>47.70</b>	0.37	113	4.2	<b>1.6</b>	<b>480</b>			C	C		281316	standard ø30  On request ø35	01
16.2	<b>86.27</b>	0.37	205	2.3	<b>0.87</b>	<b>480</b>			C	C		191316		02
14.0	<b>100.00</b>	0.37	237	2.0	<b>0.75</b>	<b>480</b>			C	C		171316		03
11.9	<b>117.38</b>	0.37	278	1.7	<b>0.64</b>	<b>480</b>			C	C		151316		04
10.0	<b>140.10</b>	0.37	332	1.4	<b>0.53</b>	<b>480</b>			C	C		131316		05
7.3	<b>191.24</b>	0.37	454	1.1	<b>0.39</b>	<b>480</b>			C	C		101316		06
5.6	<b>249.59</b>	0.25	399	1.2	<b>0.30</b>	<b>480</b>			C	C		91316		07
4.2	<b>329.58</b>	0.25	527	0.9	<b>0.23</b>	<b>480</b>			C	C		71316		08

The dynamic efficiency is **0.94** for all ratios

**A** Motor Flanges Available  
Flange Motore Disponibili

**B** Supplied with Reduction Bushing  
Fornito con Bussola di Riduzione

**B** Available on Request without reduction bushing  
Disponibile a Richiesta senza Bussola di Riduzione

**C** Motor Flange Holes Position  
Posizione Fori Flangia Motore

**EN** Unit **FS50** is supplied with synthetic oil for lifetime lubrication, no maintenance is necessary. See table 1 for lubrication and recommended quantity. In table 2 please see possible radial loads and axial loads on the gearbox.

**I** Il riduttore **FS50** viene fornito completo di olio sintetico per la lubrificazione permanente e non necessita di alcuna manutenzione. Vedi tab.1 per oli e quantità consigliati. In tab.2 sono presenti i carichi radiali e assiali applicabili al riduttore.

**D** Das Getriebe **FS50** ist mit synthetischem Öl gefüllt und ist lebensdauergeschmiert. In Tabelle 1 ist die Schmiermenge und das empfohlene Schmiermittel angegeben. In Tabelle 2 sind die zulässigen Radial- und Axialbelastungen des Getriebes aufgeführt.

**F** Le réducteur **FS50** est fourni complet avec de l'huile synthétique pour la lubrification permanente et ne nécessite aucun entretien. Voir tableau 1 concernant les huiles et les quantités conseillées. Les charges radiales et axiales applicables au réducteur sont précisées dans le tableau 2.

**E** El reductor tamaño **FS50** se suministra, lubricado de por vida con aceite sintético y no requieren mantenimiento alguna. Ver tabla 1, para cantidades y aceites recomendados. En la tabla 2, se encuentran las cargas radiales y axiales admitidas por el reductor.

Standard supplied	For these mounting position specify in the order or add oil Per queste posizioni specificare in fase d'ordine o aggiungere olio				
H1	H4	H3	H2	H5	H6
0.95 LT	0.50 LT	0.50 LT	0.70 LT	0.95 LT	0.95 LT
AGIP Telium VSF 320			SHELL Omala S4 WE 320		

For all details on lubrication and plugs check our website **tab. 1**  
Per maggiori dettagli su lubrificazione e tappi olio vedi il nostro sito web

RADIAL AND AXIAL LOADS				
Input shaft Albero in entrata		n <sub>1</sub>	FA	FR
		1400	140	700
		900	160	800
*Strong axial loads in the DX direction are not allowed. Non sono consentiti forti carichi assiali con direzione DX				

**tab. 2**

# Compact gear 480Nm FS50

**P**FS50C... Basic gearbox  
Riduttore base

Gearbox weight  
peso riduttore **11.5 kg**

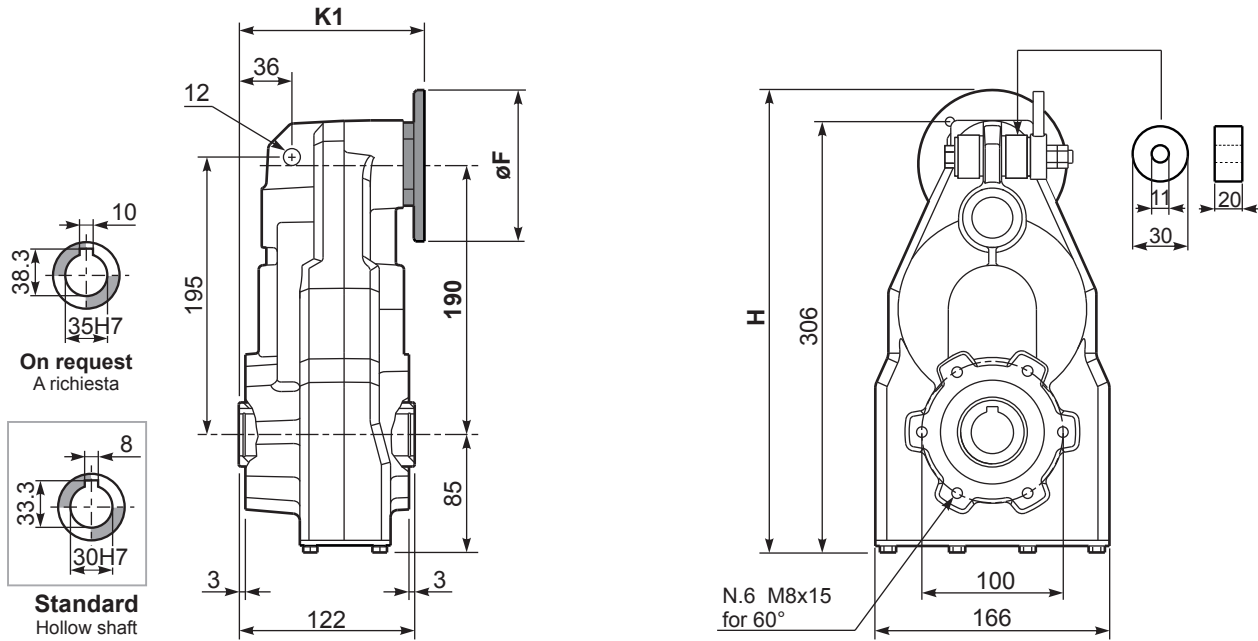

B14 Motor Flanges	H	øF	k1	kit code
56 B14	314	80	130.5	KC40.4.049
63 B14	320	90	133	K050.4.047
71 B14	328	105	130.5	K050.4.045

B5 Motor Flanges	H	øF	k1	kit code
63 B5	345	140	133	K050.4.041
71 B5	355	160	130.5	K050.4.042

**R**FS50C... Input shaft  
Albero in entrata

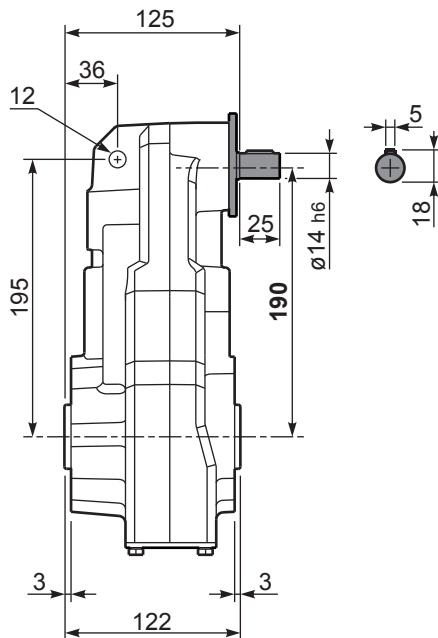





#### QUICK SELECTION / Selezione veloce

input speed ( $n_1$ ) = 1400 min<sup>-1</sup>

Output Speed $n_2$ [min <sup>-1</sup> ]	Ratio $i$	Motor power $P_{1M}$ [kW]	Output torque $M_{2M}$ [Nm]	Service factor f.s.	Nominal power $P_{1R}$ [kW]	Nominal torque $M_{2R}$ [Nm]	Available B5 motor flanges			Available B14 motor flanges			Output Shaft 	Ratios code	
							-D	-E	-F	-R	-T	-U			
							80	90	100 112	80	90	100 112			
481	<b>2.91</b>	4	76	1.8	7.2	140	B	B		B	B		3499	standard	01
373	<b>3.75</b>	4	98	1.6	6.4	160	B	B		B	B		28105	<b>ø30</b>	02
263	<b>5.33</b>	4	140	1.2	4.8	170	B	B		B	B		21112		03
219	<b>6.39</b>	4	167	1.0	4.0	170	B	B		B	B		18115	ø35	04
178	<b>7.85</b>	4	205	1.1	4.3	225	B	B		B	B		13102	On request	05

The dynamic efficiency is **0.98** for all ratios

**Motor Flanges Available**  
Flange Motore Disponibili

**B) Supplied with Reduction Bushing**  
Fornito con Bussola di Riduzione

**B) Available on Request without reduction bushing**  
Disponibile a Richiesta senza Bussola di Riduzione

**C) Motor Flange Holes Position**  
Posizione Fori Flangia Motore

**EN** Unit **FA41** is supplied with synthetic oil for lifetime lubrication, no maintenance is necessary. See table 1 for lubrication and recommended quantity. In table 2 please see possible radial loads and axial loads on the gearbox.

**I** Il riduttore **FA41** viene fornito completo di olio sintetico per la lubrificazione permanente e non necessita di alcuna manutenzione. Vedi tab.1 per oli e quantità consigliati. In tab.2 sono presenti i carichi radiali e assiali applicabili al riduttore.

**D** Das Getriebe **FA41** ist mit synthetischem Öl gefüllt und ist lebensdauergeschmiert. In Tabelle 1 ist die Schmiermenge und das empfohlene Schmiermittel angegeben. In Tabelle 2 sind die zulässigen Radial- und Axialbelastungen des Getriebes aufgeführt.

**F** Le réducteur **FA41** est fourni complet avec de l'huile synthétique pour la lubrification permanente et ne nécessite aucun entretien. Voir tableau 1 concernant les huiles et les quantités conseillées. Les charges radiales et axiales applicables au réducteur sont précisées dans le tableau 2.

**E** El reductor tamaño **FA41** se suministra, lubricado de por vida con aceite sintético y no requieren mantenimiento alguna. Ver tabla 1, para cantidades y aceites recomendados. En la tabla 2, se encuentran las cargas radiales y axiales admitidas por el reductor.

Standard supplied	For these mounting position specify in the order or add oil Per queste posizioni specificare in fase d'ordine o aggiungere olio				
1.10 LT	0.65 LT	0.65 LT	0.65 LT	1.15 LT	0.80 LT
AGIP Telium VSF 320			SHELL Omala S4 WE 320		

For all details on lubrication and plugs check our website **tab. 1**  
Per maggiori dettagli su lubrificazione e tappi olio vedi il nostro sito web

#### RADIAL AND AXIAL LOADS

**Output shaft**  
Albero di uscita

$F_{eq} = F_R \cdot \frac{127.5}{X+97.5}$

$n_2$ [min <sup>-1</sup> ]	FA	FR	$n_2$ [min <sup>-1</sup> ]	FA	FR	$n_2$ [min <sup>-1</sup> ]	FA	FR
300	300	1500	140	390	1950	70	490	2450
250	320	1600	120	410	2050	40	590	2950
200	350	1750	85	460	2300	15	800	4000

**On request reinforced bearings to increase loads.**  
A richiesta cuscinetti rinforzati per aumentare i carichi.

tab. 2

**PFA41C...**

Basic gearbox  
Riduttore base

Gearbox weight  
peso riduttore **12.1 kg**

M. flanges	Kit code	øF	A
<b>80/90B5</b>	K023.4.042	200	179.5
<b>100/112B5</b>	K023.4.043	250	188.5
<b>80B14</b>	K085.4.046	120	179.5
<b>90B14</b>	K085.4.045	140	179.5
<b>100/112B14</b>	K085.4.047	160	188.5

● Available torque arms,  
see our web site  
Bracci di reazione disponibili,  
consulta il nostro sito web

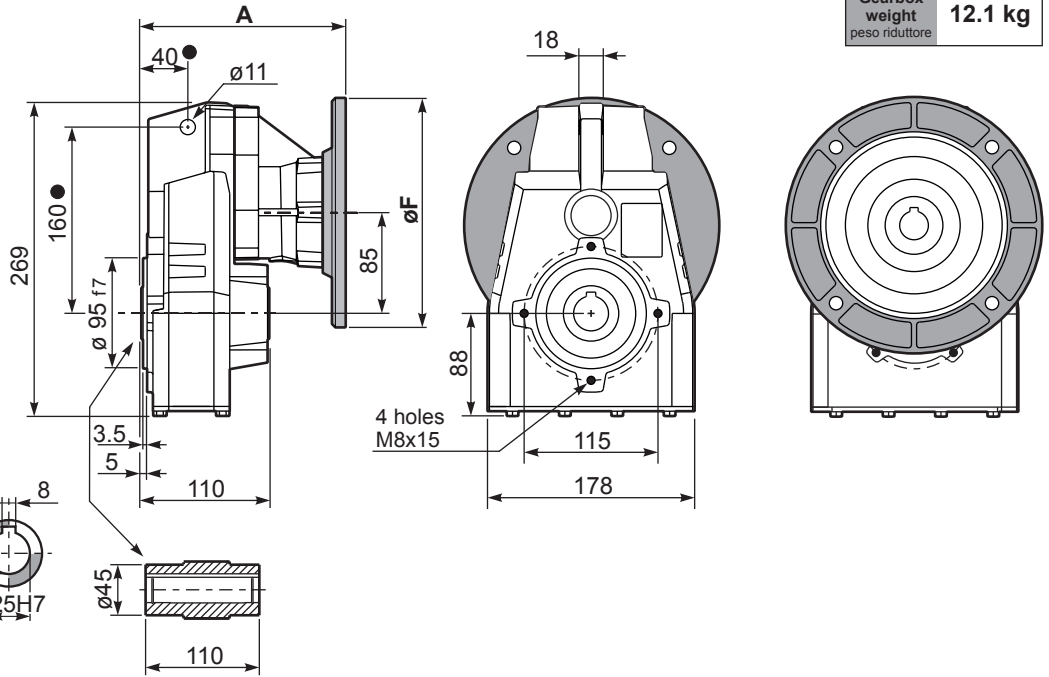

**PFA41...-F...**

Output flange  
Flangia uscita

M. flanges	k1
<b>80/90B5</b>	215.5
<b>100/112B5</b>	221.5
<b>80B14</b>	213.5
<b>90B14</b>	213.5
<b>100/112B14</b>	224.5

Available output flanges  
Flange di uscita

a1 ø	b1	c1	e1	f1	s1	Kit code
160	110	10	130	3	9	KX5A.9.010
200	130	13	165	3.5	11	KX5A.9.011
250	180	14	215	4	14	KX5A.9.012

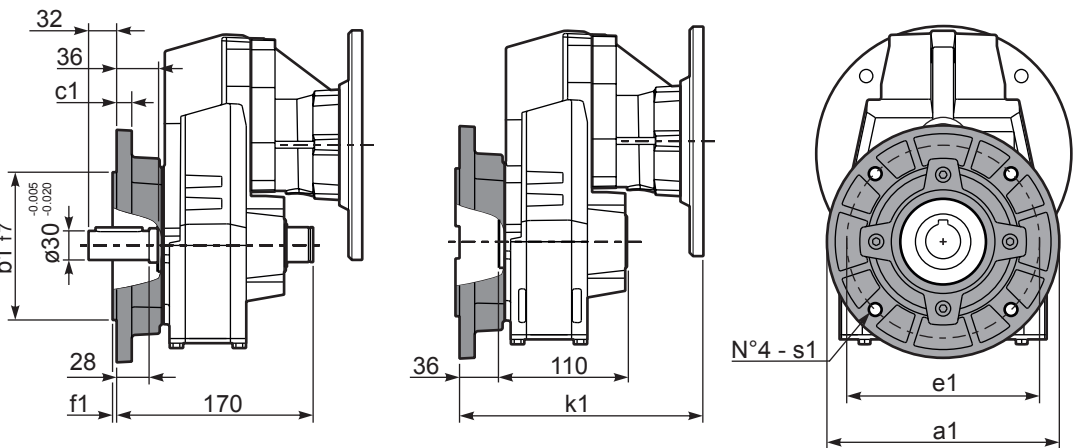

**PFA41 A...**

Single output shaft  
Albero uscita semplice

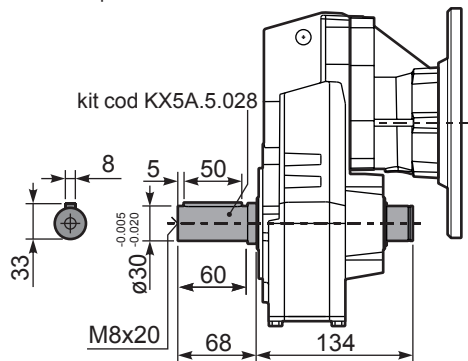



QUICK SELECTION / Selezione veloce							input speed (n <sub>1</sub> ) = 1400 min <sup>-1</sup>										
Output Speed n <sub>2</sub> [min <sup>-1</sup> ]	Ratio i	Motor power P <sub>1M</sub> [kW]	Output torque M <sub>2M</sub> [Nm]	Service factor f.s.	Nominal power P <sub>1R</sub> [kW]	Nominal torque M <sub>2R</sub> [Nm]	Available B5 motor flanges					Available B14 motor flanges				Output Shaft 	Ratios code 
							-B	-C	-D	-E	-F	-Q	-R	-T	-U		
							63	71	80	90	100	112	71	80	90		
167	8.38	4	215	1.0	4.1	225	B					C	C			2821	01
139	10.04	3	194	1.2	3.7	240	B					C	C			2818	02
114	12.33	3	238	1.1	3.2	260	B					C	C			2813	03
92	15.16	2.2	215	1.2	2.6	260	B					C	C			1921	04
80	17.57	2.2	250	1.1	2.3	270	B					C	C			1721	05
77	18.16	2.2	258	1.1	2.4	290	B					C	C			1918	06
67	21.05	2.2	299	1.1	2.3	320	B					C	C			1718	07
63	22.30	2.2	317	1.0	2.2	320	B					C	C			1913	08
57	24.70	1.5	242	1.3	2.0	320	B					C	C			1518	09
54	25.85	1.5	253	1.3	1.9	320	B					C	C			1713	10
47.5	29.49	1.5	289	1.1	1.7	320	B					C	C			1318	11
46.1	30.34	1.5	297	1.1	1.6	320	B					C	C			1513	12
41.7	33.60	1.1	240	1.0	1.1	250	B					C	C			1021	13
38.7	36.21	1.1	259	1.2	1.3	320	B					C	C			1313	14
34.8	40.25	1.1	288	1.0	1.1	300	B					C	C			1018	15
28.3	49.43	1.1	354	0.9	0.99	320	B					C	C			1013	16
26.7	52.53	0.75	258	1.0	0.76	260	B					C	C			918	17
21.7	64.51	0.75	317	1.0	0.75	315	B					C	C			913	18
20.2	69.37	0.37	168	1.1	0.42	190	B					C	C			718	19
16.4	85.19	0.37	206	1.1	0.41	230	B					C	C			713	20

The dynamic efficiency is **0.96** for all ratios

Motor Flanges Available Flange Motore Disponibili    
 B) Supplied with Reduction Bushing Fornito con Bussola di Riduzione    
 B) Available on Request without reduction bushing Disponibile a Richiesta senza Bussola di Riduzione    
 C) Motor Flange Holes Position Posizione Fori Flangia Motore

**EN** Unit **FA42** is supplied with synthetic oil for lifetime lubrication, no maintenance is necessary. See table 1 for lubrication and recommended quantity. In table 2 please see possible radial loads and axial loads on the gearbox.

**I** Il riduttore **FA42** viene fornito completo di olio sintetico per la lubrificazione permanente e non necessita di alcuna manutenzione. Vedi tab.1 per oli e quantità consigliati. In tab.2 sono presenti i carichi radiali e assiali applicabili al riduttore.

**D** Das Getriebe **FA42** ist mit synthetischem Öl gefüllt und ist lebensdauergeschmiert. In Tabelle 1 ist die Schmiermenge und das empfohlene Schmiermittel angegeben. In Tabelle 2 sind die zulässigen Radial - und Axialbelastungen des Getriebes aufgeführt.

**F** Le réducteur **FA42** est fourni complet avec de l'huile synthétique pour la lubrification permanente et ne nécessite aucun entretien. Voir tableau 1 concernant les huiles et les quantités conseillées. Les charges radiales et axiales applicables au réducteur sont précisées dans le tableau 2.

**E** El reductor tamaño **FA42** se suministra, lubricado de por vida con aceite sintético y no requieren mantenimiento alguna. Ver tabla 1, para cantidades y aceites recomendados. En la tabla 2, se encuentran las cargas radiales y axiales admitidas por el reductor.

Standard supplied	For these mounting position specify in the order or add oil Per queste posizioni specificare in fase d'ordine o aggiungere olio				
1.15 LT	0.70 LT	0.70 LT	0.70 LT	1.20 LT	0.80 LT
AGIP Telium VSF 320			SHELL Omala S4 WE 320		

For all details on lubrication and plugs check our website [tab. 1](#)  
Per maggiori dettagli su lubrificazione e tappi olio vedi il nostro sito web

### RADIAL AND AXIAL LOADS

**Output shaft**  
Albero di uscita

$F_{eq} = FR \cdot \frac{127.5}{X+97.5}$

n <sub>2</sub> [min <sup>-1</sup> ]	FA	FR	n <sub>2</sub> [min <sup>-1</sup> ]	FA	FR	n <sub>2</sub> [min <sup>-1</sup> ]	FA	FR
300	300	1500	140	390	1950	70	490	2450
250	320	1600	120	410	2050	40	590	2950
200	350	1750	85	460	2300	15	800	4000

**On request reinforced bearings to increase loads.**  
A richiesta cuscinetti rinforzati per aumentare i carichi.

**Input shaft**  
Albero in entrata

n <sub>1</sub>	FA	FR
1400	240	1200
900	280	1400
500	340	1700

tab. 2

**PFA42C...**

Basic gearbox  
Riduttore base

Gearbox weight  
peso riduttore **9.0 kg**

M. flanges	Kit code	øF	A
63B5	K063.4.041	140	169.5
71B5	K063.4.042	160	167.5
80/90B5	K063.4.043	200	169.5
100/112B5	KC40.4.043	250	184.5
71B14	K063.4.047	105	167.5
80B14	K063.4.046	120	169.5
90B14	K063.4.041	140	169.5
100/112B14	KC40.4.041	160	184.5

● Available torque arms,  
see our web site  
Bracci di reazione disponibili,  
consulta il nostro sito web

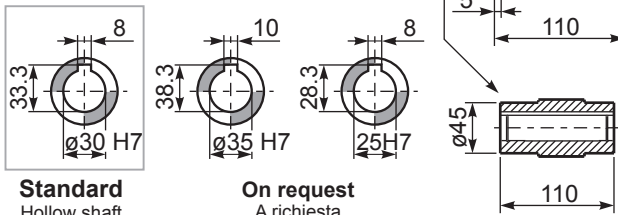

**Standard**  
Hollow shaft

**On request**  
A richiesta

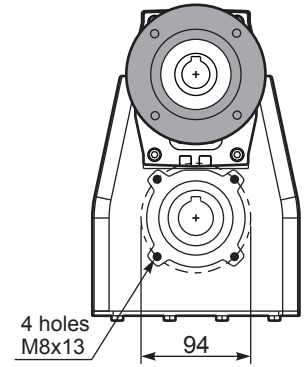
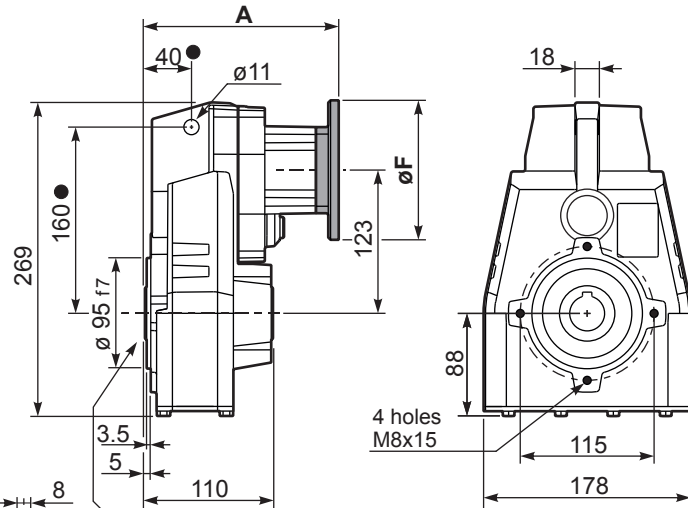

**PFA42...-F...**

Output flange  
Flangia uscita

Motor Flange	k1
63B5	205.5
71B5	203.5
80/90B5	205.5
100/112B5	221
71B14	203.5
80B14	204.5
90B14	205.5
100/112B14	221

Available output flanges  
Flange di uscita

a1 ø	b1	c1	e1	f1	s1	Kit code
160	110	10	130	3	9	KX5A.9.010
200	130	13	165	3.5	11	KX5A.9.011
250	180	14	215	4	14	KX5A.9.012

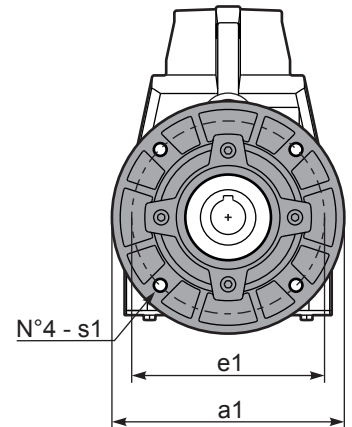
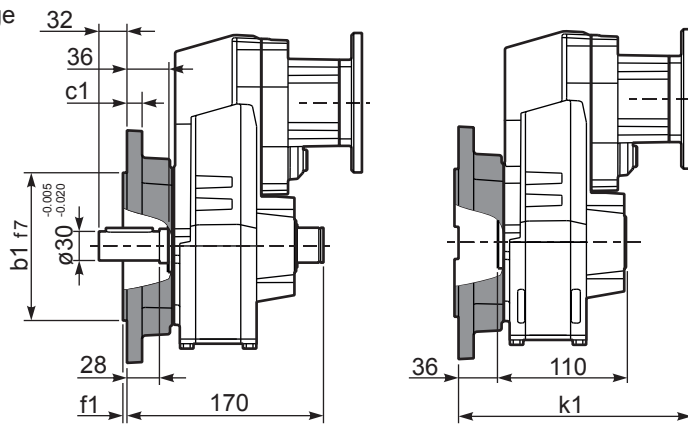

**RFA42C...**

Input Shaft  
Albero in entrata

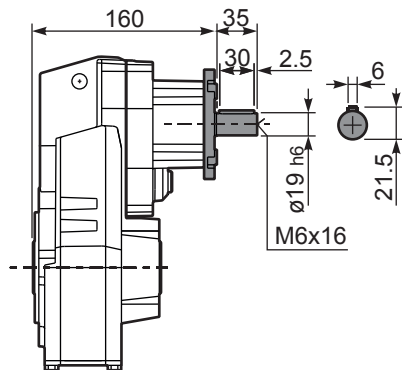

**PFA42 A...**

Single output shaft  
Albero uscita semplice

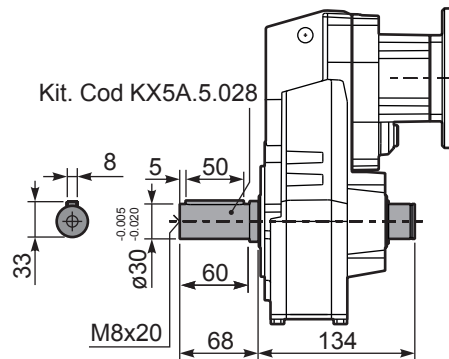

**PFA42D...**

Shrink disk  
Calettatore

Kit. Cod KF40.0.210LM

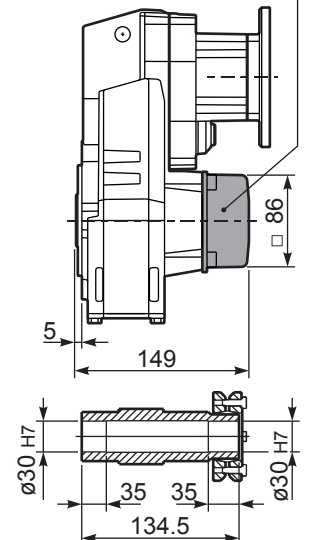



### QUICK SELECTION / Selezione veloce

input speed ( $n_1$ ) = 1400 min<sup>-1</sup>

Output Speed $n_2$ [min <sup>-1</sup> ]	Ratio $i$	Motor power $P_{1M}$ [kW]	Output torque $M_{2M}$ [Nm]	Service factor f.s.	Nominal power $P_{1R}$ [kW]	Nominal torque $M_{2R}$ [Nm]	Available B5 motor flanges		Available B14 motor flanges			Output Shaft 	Ratios code
							-B	-C	-O	-P	-Q		
							63	71	56	63	71		
18.8	<b>74.33</b>	0.37	176	1.8	<b>0.67</b>	<b>320</b>			C	C		191313	01
17.0	<b>82.56</b>	0.37	196	1.6	<b>0.60</b>	<b>320</b>			C	C		151318	02
16.0	<b>87.48</b>	0.37	207	1.5	<b>0.57</b>	<b>320</b>			C	C		131713	03
13.8	<b>101.40</b>	0.37	240	1.3	<b>0.49</b>	<b>320</b>			C	C		151313	04
11.4	<b>122.57</b>	0.37	291	1.1	<b>0.41</b>	<b>320</b>			C	C		131313	05
10.1	<b>138.59</b>	0.37	329	1.0	<b>0.36</b>	<b>320</b>			C	C		101318	06
8.7	<b>160.82</b>	0.25	257	1.2	<b>0.31</b>	<b>320</b>			C	C		91713	07
8.2	<b>170.20</b>	0.25	272	1.2	<b>0.29</b>	<b>320</b>			C	C		101313	08
7.6	<b>183.48</b>	0.25	294	1.1	<b>0.27</b>	<b>320</b>			C	C		91318	09
6.5	<b>214.15</b>	0.18	262	1.2	<b>0.23</b>	<b>320</b>			C	C		71713	10
6.2	<b>225.33</b>	0.18	276	1.2	<b>0.22</b>	<b>320</b>			C	C		91313	11
5.7	<b>244.32</b>	0.18	299	1.1	<b>0.20</b>	<b>320</b>			C	C		71318	12
5.5	<b>254.15</b>	0.18	311	1.0	<b>0.20</b>	<b>320</b>			C	C		61713	13
4.8	<b>289.96</b>	0.18	355	0.9	<b>0.17</b>	<b>320</b>			C	C		61318	14
4.7	<b>300.05</b>	0.18	367	0.9	<b>0.17</b>	<b>320</b>			C	C		71313	15
3.9	<b>356.09</b>	0.12	282	1.1	<b>0.14</b>	<b>320</b>			C	C		61313	16

The dynamic efficiency is **0.94** for all ratios

**Motor Flanges Available**  
Flange Motore Disponibili

**B) Supplied with Reduction Bushing**  
Fornito con Bussola di Riduzione

**B) Available on Request without reduction bushing**  
Disponibile a Richiesta senza Bussola di Riduzione

**C) Motor Flange Holes Position**  
Posizione Fori Flangia Motore

**EN** Unit **FA43** is supplied with synthetic oil for lifetime lubrication, no maintenance is necessary. See table 1 for lubrication and recommended quantity. In table 2 please see possible radial loads and axial loads on the gearbox.

**I** Il riduttore **FA43** viene fornito completo di olio sintetico per la lubrificazione permanente e non necessita di alcuna manutenzione. Vedi tab.1 per oli e quantità consigliati. In tab.2 sono presenti i carichi radiali e assiali applicabili al riduttore.

**D** Das Getriebe **FA43** ist mit synthetischem Öl gefüllt und ist lebensdauergeschmiert. In Tabelle 1 ist die Schmiermenge und das empfohlene Schmiermittel angegeben. In Tabelle 2 sind die zulässigen Radial- und Axialbelastungen des Getriebes aufgeführt.

**F** Le réducteur **FA43** est fourni complet avec de l'huile synthétique pour la lubrification permanente et ne nécessite aucun entretien. Voir tableau 1 concernant les huiles et les quantités conseillées. Les charges radiales et axiales applicables au réducteur sont précisées dans le tableau 2.

**E** El reductor tamaño **FA43** se suministra, lubricado de por vida con aceite sintético y no requieren mantenimiento alguna. Ver tabla 1, para cantidades y aceites recomendados. En la tabla 2, se encuentran las cargas radiales y axiales admitidas por el reductor.

Standard supplied	For these mounting position specify in the order or add oil Per queste posizioni specificare in fase d'ordine o aggiungere olio				
H1	H4	H3	H2	H5	H6
1.30 LT	0.70 LT	0.70 LT	0.70 LT	1.35 LT	0.90 LT
AGIP Telium VSF 320			SHELL Omala S4 WE 320		

For all details on lubrication and plugs check our website **tab. 1**  
Per maggiori dettagli su lubrificazione e tappi olio vedi il nostro sito web

### RADIAL AND AXIAL LOADS



$n_2$ [min <sup>-1</sup> ]	FA	FR	$n_2$ [min <sup>-1</sup> ]	FA	FR	$n_2$ [min <sup>-1</sup> ]	FA	FR
<b>300</b>	300	1500	<b>140</b>	390	1950	<b>70</b>	490	2450
<b>250</b>	320	1600	<b>120</b>	410	2050	<b>40</b>	590	2950
<b>200</b>	350	1750	<b>85</b>	460	2300	<b>15</b>	800	4000

**On request reinforced bearings to increase loads.**  
A richiesta cuscinetti rinforzati per aumentare i carichi.

$n_1$	FA	FR
<b>1400</b>	140	700
<b>900</b>	160	800
<b>500</b>	190	950

tab. 2



**PFA43C...**

Basic gearbox  
Riduttore base

Gearbox weight  
peso riduttore **8.9 kg**

M. flanges	Kit code	øF	A
63B5	K050.4.041	138	175
71B5	K050.4.042	160	172.5
56B14	KC40.4.049	80	172.5
63B14	K050.4.047	90	175
71B14	K050.4.045	105	172.5

● Available torque arms,  
see our web site  
Bracci di reazione disponibili,  
consulta il nostro sito web

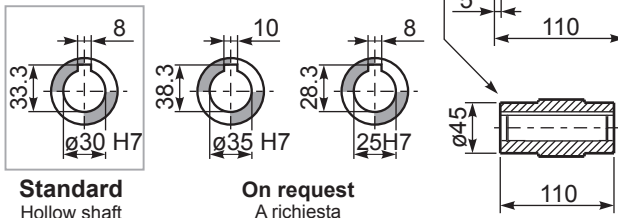

**Standard**  
Hollow shaft

**On request**  
A richiesta

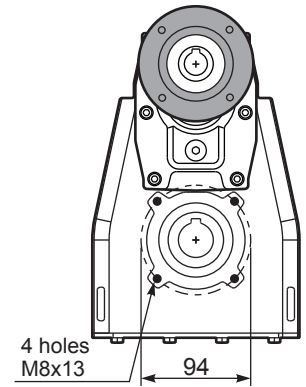
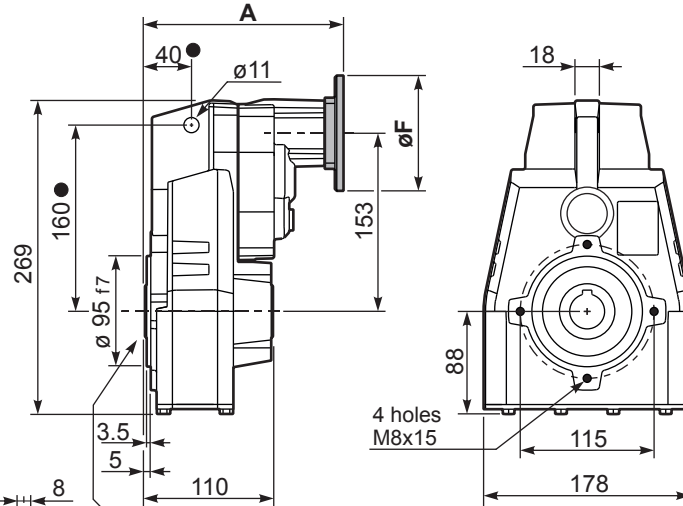

**PFA43...-F...**

Output flange  
Flangia uscita

Motor Flange	k1
63B5	209
71B5	207
56B14	208.5
63B14	211
71B14	208.5

Available output flanges  
Flange di uscita

a1 ø	b1	c1	e1	f1	s1	Kit code
160	110	10	130	3	9	KX5A.9.010
200	130	13	165	3.5	11	KX5A.9.011
250	180	14	215	4	14	KX5A.9.012

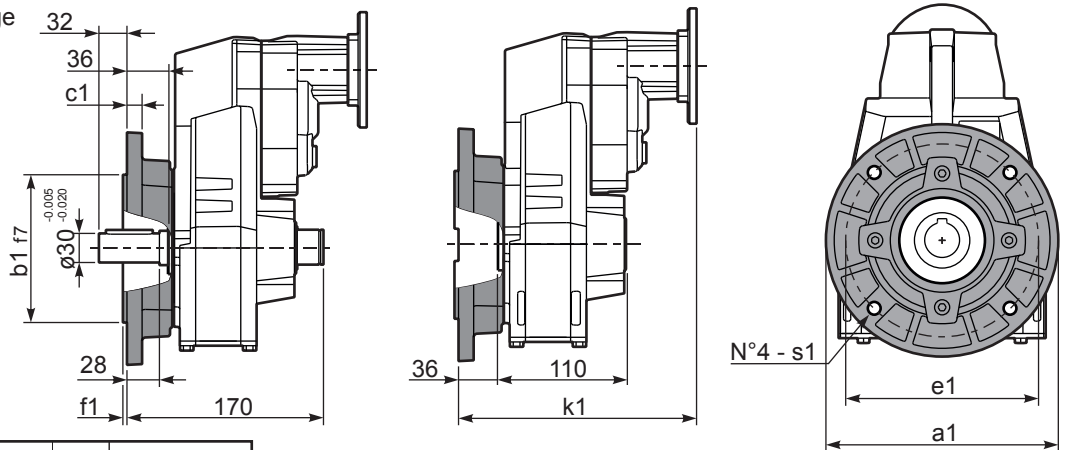

**RFA43C...**

Input Shaft  
Albero in entrata

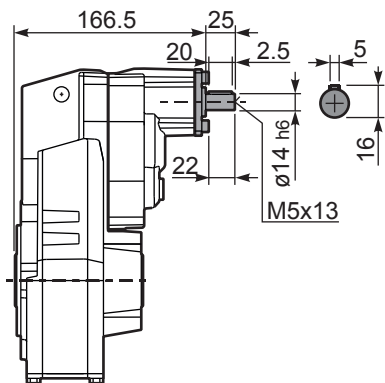

**PFA43 A...**

Single output shaft  
Albero uscita semplice

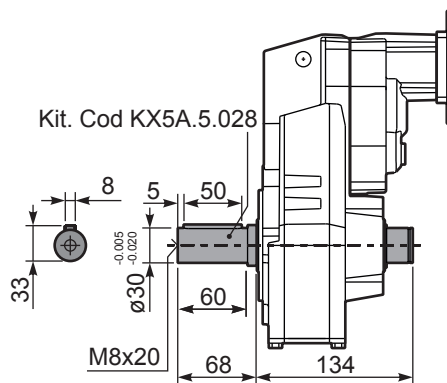

**PFA43D...**

Shrink disk  
Calettatore

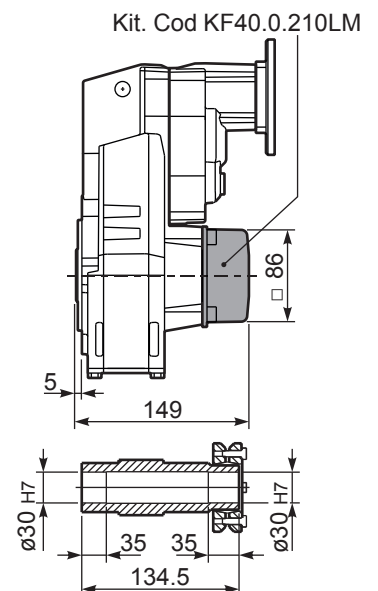



#### QUICK SELECTION / Selezione veloce

input speed ( $n_1$ ) = 1400 min<sup>-1</sup>

Output Speed $n_2$ [min <sup>-1</sup> ]	Ratio $i$	Motor power $P_{1M}$ [kW]	Output torque $M_{2M}$ [Nm]	Service factor $f.s.$	Nominal power $P_{1R}$ [kW]	Nominal torque $M_{2R}$ [Nm]	Available B5 motor flanges					Available B14 motor flanges				Output Shaft 	Output Shaft 	Ratios code 
							-C	-D	-E	-F	-G	-R	-T	-U	-V			
							71	80	90	100 112	132	80	90	100 112	132			
213	<b>6.57</b>	5.5	230	1.2	6.5	280	B										3018	01
185	<b>7.56</b>	5.5	265	1.1	5.9	290	B										3016	02
159	<b>8.82</b>	5.5	309	1.0	5.5	320	B										3014	03
113	<b>12.39</b>	5.5	434	1.0	5.5	450	B										2018	04
98	<b>14.24</b>	5.5	499	0.9	4.8	450	B										2016	05
84	<b>16.75</b>	4	429	1.1	4.3	470	B										1618	06
73	<b>19.25</b>	4	494	1.0	3.9	490	B										1616	07
64	<b>21.78</b>	4	558	0.9	3.4	490	B										1318	08
56	<b>25.04</b>	3	483	1.0	3.0	490	B										1316	09
47.9	<b>29.23</b>	3	564	0.9	2.6	490	B										1314	10
45.7	<b>30.65</b>	2.2	436	1.1	2.4	490	B										1116	11
39.1	<b>35.78</b>	2.2	509	1.0	2.1	490	B										1114	12
36.3	<b>38.55</b>	2.2	548	0.9	1.9	490	B										818	13
31.6	<b>44.32</b>	1.5	434	1.1	1.7	490	B										816	14
27.1	<b>51.74</b>	1.5	507	1.0	1.4	490	B										814	15
22.9	<b>61.03</b>	1.1	437	1.1	1.2	480	B										616	16
19.6	<b>71.25</b>	1.1	510	1.0	1.1	490	B										614	17

The dynamic efficiency is **0.96** for all ratios

- Motor Flanges Available**  
Flange Motore Disponibili
- B) Supplied with Reduction Bushing**  
Fornito con Bussola di Riduzione
- B) Available on Request without reduction bushing**  
Disponibile a Richiesta senza Bussola di Riduzione
- C) Motor Flange Holes Position**  
Posizione Fori Flangia Motore

**EN** Unit **FA52** is supplied with synthetic oil for lifetime lubrication, no maintenance is necessary. See table 1 for lubrication and recommended quantity. In table 2 please see possible radial loads and axial loads on the gearbox.

**I** Il riduttore **FA52** viene fornito completo di olio sintetico per la lubrificazione permanente e non necessita di alcuna manutenzione. Vedi tab.1 per oli e quantità consigliati. In tab.2 sono presenti i carichi radiali e assiali applicabili al riduttore.

**D** Das Getriebe **FA52** ist mit synthetischem Öl gefüllt und ist lebensdauergeschmiert. In Tabelle 1 ist die Schmiermenge und das empfohlene Schmiermittel angegeben. In Tabelle 2 sind die zulässigen Radial- und Axialbelastungen des Getriebes aufgeführt.

**F** Le réducteur **FA52** est fourni complet avec de l'huile synthétique pour la lubrification permanente et ne nécessite aucun entretien. Voir tableau 1 concernant les huiles et les quantités conseillées. Les charges radiales et axiales applicables au réducteur sont précisées dans le tableau 2.

**E** El reductor tamaño **FA52** se suministra, lubricado de por vida con aceite sintético y no requieren mantenimiento alguna. Ver tabla 1, para cantidades y aceites recomendados. En la tabla 2, se encuentran las cargas radiales y axiales admitidas por el reductor.

Standard supplied	For these mounting position specify in the order or add oil Per queste posizioni specificare in fase d'ordine o aggiungere olio				
1.85 LT	1.15 LT	1.15 LT	1.30 LT	2.10 LT	1.30 LT
AGIP Telium VSF 320			SHELL Omala S4 WE 320		

For all details on lubrication and plugs check our website **tab. 1**  
Per maggiori dettagli su lubrificazione e tappi olio vedi il nostro sito web

### RADIAL AND AXIAL LOADS

**Output shaft**  
Albero di uscita

$F_{eq} = FR \cdot \frac{149.5}{X+119.5}$

$n_2$	FA	FR	$n_2$	FA	FR	$n_2$	FA	FR
300	400	2000	140	460	2300	70	580	2900
250	420	2100	120	500	2500	40	780	3900
200	440	2200	85	550	2750	15	1140	5700

**On request reinforced bearings to increase loads.**  
A richiesta cuscinetti rinforzati per aumentare i carichi.

**Input shaft**  
Albero in entrata

$n_1$	FA	FR
1400	400	2000
900	440	2200
500	440	2200

tab. 2

**PFA52C...**

Basic gearbox  
Riduttore base

Gearbox weight  
peso riduttore **15.5 kg**

M. flanges	Kit code	øF	A
71B5	K023.4.041	160	227
80/90B5	K023.4.042	200	229
100/112B5	K023.4.043	250	238
132B5	KC50.4.043	300	256
80B14	K085.4.046	120	229
90B14	K085.4.045	140	229
100/112B14	K085.4.047	160	238
132B14	KC50.4.041	200	256

● Available torque arms,  
see our web site  
Bracci di reazione disponibili,  
consulta il nostro sito web

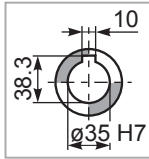

**Standard**  
Hollow shaft

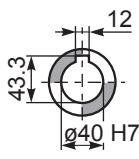

**On request**  
A richiesta

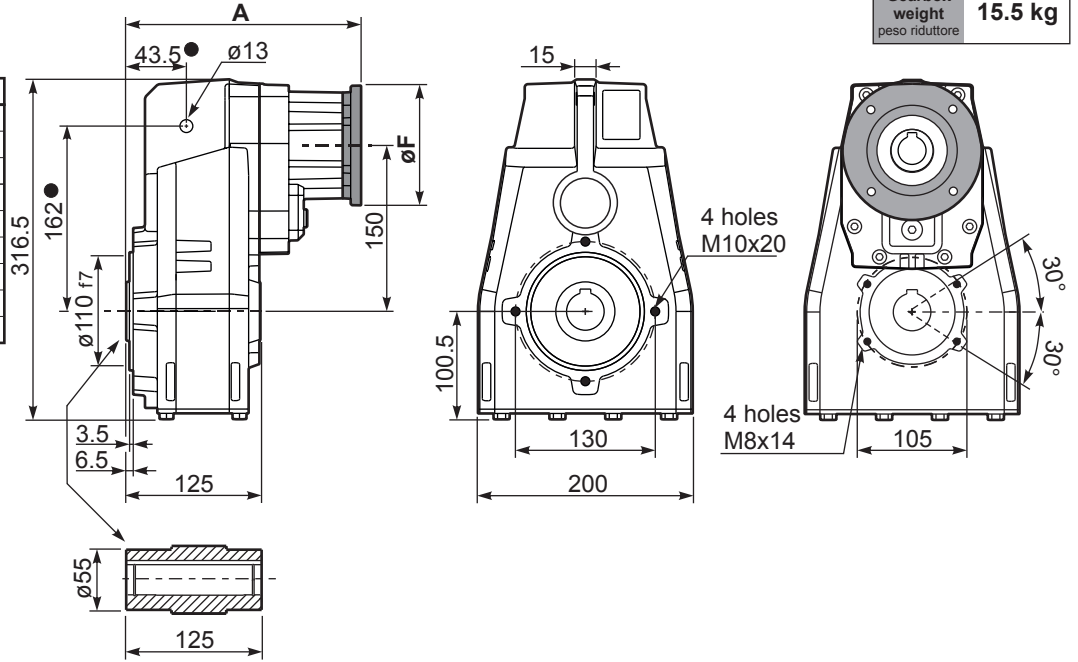

**PFA52...-F...**

Output flange  
Flangia uscita

M. flanges	k1
71B5	260
80/90B5	262
100/112B5	268
132B5	289.5
80B14	260
90B14	260
100/112B14	271
132B14	289.5

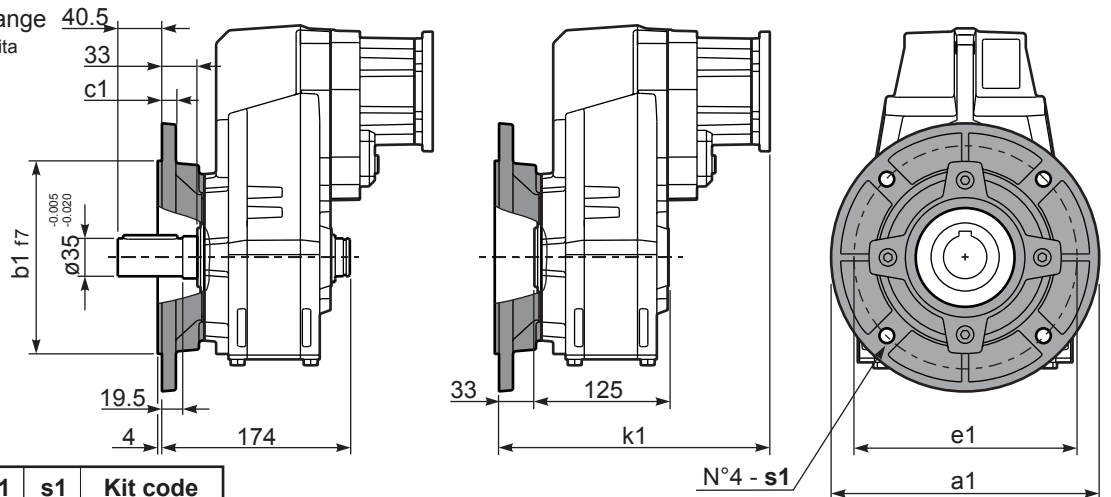

Available output flanges  
Flange di uscita

a1 ø	b1	c1	e1	s1	Kit code
250	180	13	215	14	KF60.9.011
300	230	16	265	14	KF60.9.012

**RFA52C...**

Input Shaft  
Albero in entrata

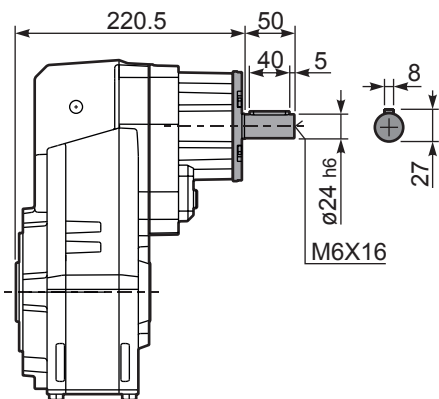

**PFA52 A...**

Single output shaft  
Albero uscita semplice

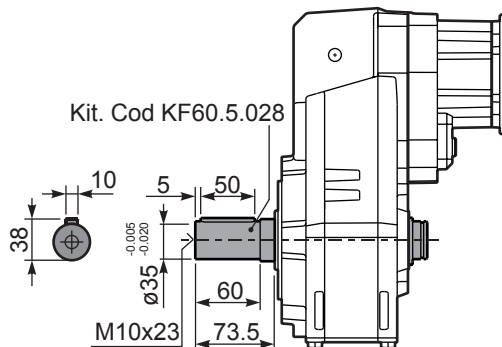

**PFA52D...**

Shrink disk  
Calettatore

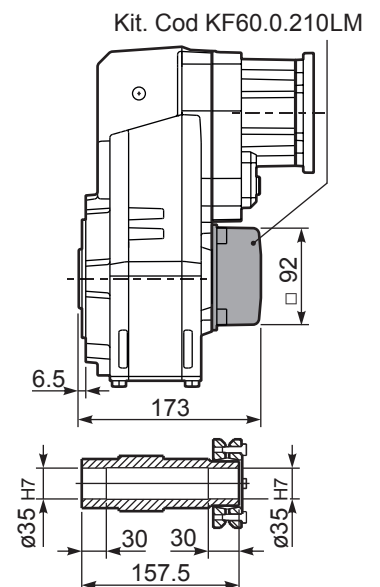



### QUICK SELECTION / Selezione veloce

input speed ( $n_1$ ) = 1400 min<sup>-1</sup>

Output Speed $n_2$ [min <sup>-1</sup> ]	Ratio $i$	Motor power $P_{1M}$ [kW]	Output torque $M_{2M}$ [Nm]	Service factor f.s.	Nominal power $P_{1R}$ [kW]	Nominal torque $M_{2R}$ [Nm]	Available B5 motor flanges				Available B14 motor flanges			Output Shaft 	Ratios code
							-B	-C	-D	-E	-Q	-R	-T		
							63	71	80	90	71	80	90		
22.6	<b>61.89</b>	1.1	434	1.2	1.3	510	B				C	C		191318	01
19.7	<b>71.16</b>	1.1	499	1.0	1.1	510	B				C	C		191316	02
17.0	<b>82.48</b>	1.1	578	0.9	0.96	510	B				C	C		171316	03
14.5	<b>96.29</b>	0.75	463	1.1	0.83	510	B				C	C		171314	04
13.9	<b>100.51</b>	0.75	483	1.1	0.79	510	B				C	C		131318	05
12.1	<b>115.56</b>	0.55	410	1.2	0.69	510	B				C	C		131316	06
11.1	<b>125.96</b>	0.55	447	1.1	0.63	510	B				C	C		190816	07
10.4	<b>134.91</b>	0.55	479	1.1	0.59	510	B				C	C		131314	08
9.5	<b>147.05</b>	0.55	522	1.0	0.54	510	B				C	C		190814	09
8.2	<b>170.44</b>	0.37	404	1.3	0.47	510	B				C	C		170814	10
7.6	<b>184.15</b>	0.37	437	1.2	0.43	510	B				C	C		101314	11
6.8	<b>205.87</b>	0.37	488	1.0	0.39	510	B				C	C		91316	12
5.8	<b>240.34</b>	0.37	570	0.9	0.33	510	B				C	C		91314	13
5.0	<b>279.22</b>	0.25	447	1.1	0.28	510	B				C	C		100816	14
4.3	<b>325.97</b>	0.25	522	1.0	0.24	510	B				C	C		100814	15
3.8	<b>364.41</b>	0.18	446	1.1	0.22	510	B				C	C		90816	16
3.3	<b>425.43</b>	0.18	521	1.0	0.19	510	B				C	C		90814	17
2.9	<b>481.19</b>	0.18	589	0.9	0.17	510	B				C	C		70816	18
2.5	<b>561.76</b>	0.12	444	1.1	0.14	510	B				C	C		70814	19

The dynamic efficiency is 0.94 for all ratios

- M** Motor Flanges Available Flange Motore Disponibili
- B** Supplied with Reduction Bushing Fornito con Bussola di Riduzione
- B** Available on Request without reduction bushing Disponibile a Richiesta senza Bussola di Riduzione
- C** Motor Flange Holes Position Posizione Fori Flangia Motore

**EN** Unit FA53 is supplied with synthetic oil for lifetime lubrication, no maintenance is necessary. See table 1 for lubrication and recommended quantity. In table 2 please see possible radial loads and axial loads on the gearbox.

**I** Il riduttore FA53 viene fornito completo di olio sintetico per la lubrificazione permanente e non necessita di alcuna manutenzione. Vedi tab.1 per oli e quantità consigliati. In tab.2 sono presenti i carichi radiali e assiali applicabili al riduttore.

**D** Das Getriebe FA53 ist mit synthetischem Öl gefüllt und ist lebensdauer geschmiert. In Tabelle 1 ist die Schmiermenge und das empfohlene Schmiermittel angegeben. In Tabelle 2 sind die zulässigen Radial - und Axialbelastungen des Getriebes aufgeführt.

**F** Le réducteur FA53 est fourni complet avec de l'huile synthétique pour la lubrification permanente et ne nécessite aucun entretien. Voir tableau 1 concernant les huiles et les quantités conseillées. Les charges radiales et axiales applicables au réducteur sont précisées dans le tableau 2.

**E** El reductor tamaño FA53 se suministra, lubricado de por vida con aceite sintético y no requieren mantenimiento alguna. Ver tabla 1, para cantidades y aceites recomendados. En la tabla 2, se encuentran las cargas radiales y axiales admitidas por el reductor.

Standard supplied	For these mounting position specify in the order or add oil Per queste posizioni specificare in fase d'ordine o aggiungere olio				
2.15 LT	1.25 LT	1.25 LT	1.45 LT	2.35 LT	1.45 LT
AGIP Telium VSF 320			SHELL Omala S4 WE 320		

For all details on lubrication and plugs check our website **tab. 1**  
Per maggiori dettagli su lubrificazione e tappi olio vedi il nostro sito web

### RADIAL AND AXIAL LOADS

**Output shaft**  
Albero di uscita

$F_{eq} = FR \cdot \frac{149.5}{X+119.5}$

$n_2$	FA	FR	$n_2$	FA	FR	$n_2$	FA	FR
300	400	2000	140	460	2300	70	580	2900
250	420	2100	120	500	2500	40	780	3900
200	440	2200	85	550	2750	15	1140	5700

**On request reinforced bearings to increase loads.**  
A richiesta cuscinetti rinforzati per aumentare i carichi.

**Input shaft**  
Albero in entrata

$n_1$	FA	FR
1400	240	1200
900	280	1400
500	340	1700

tab. 2

**PFA53C...** Basic gearbox  
Riduttore base

Gearbox weight **15.5 kg**  
peso riduttore

M. flanges	Kit code	øF	A
<b>63B5</b>	K063.4.041	140	239
<b>71B5</b>	K063.4.042	160	237
<b>80/90B5</b>	K063.4.043	200	239
<b>71B14</b>	K063.4.047	105	237
<b>80B14</b>	K063.4.046	120	239
<b>90B14</b>	K063.4.041	140	239

● Available torque arms,  
see our web site  
Bracci di reazione disponibili,  
consulta il nostro sito web

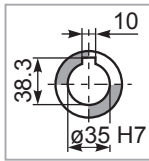

**Standard**  
Hollow shaft

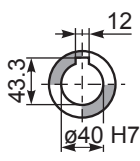

**On request**  
A richiesta

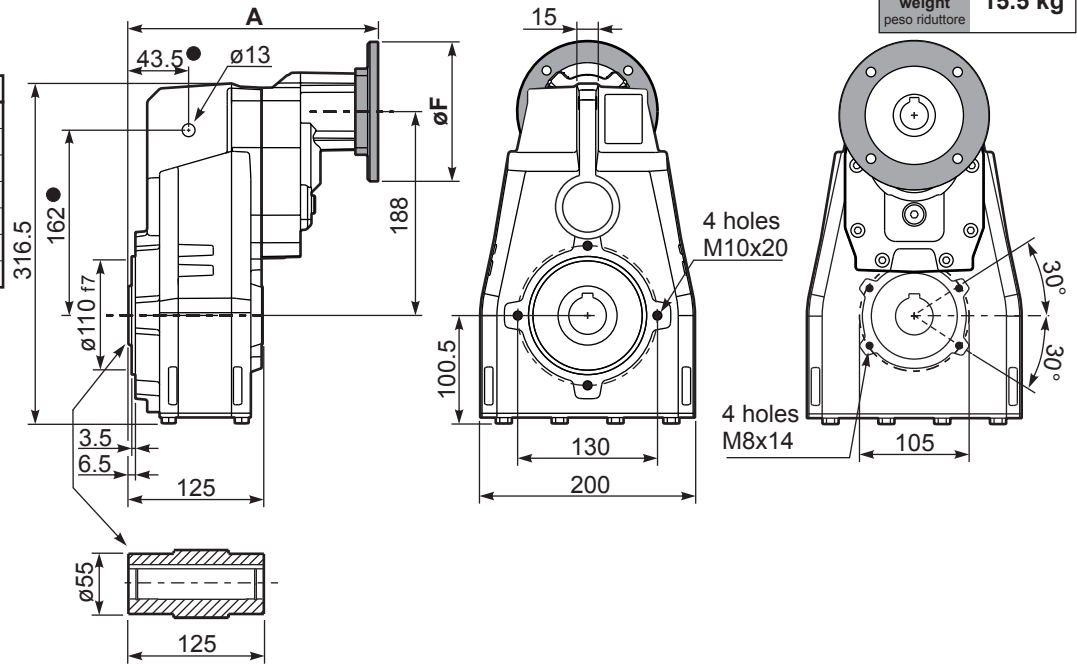

**PFA53...-F...** Output flange  
Flangia uscita

Motor Flange	k1
63B5	272
71B5	270
80/90B5	272
71B14	270
80B14	271
90B14	272

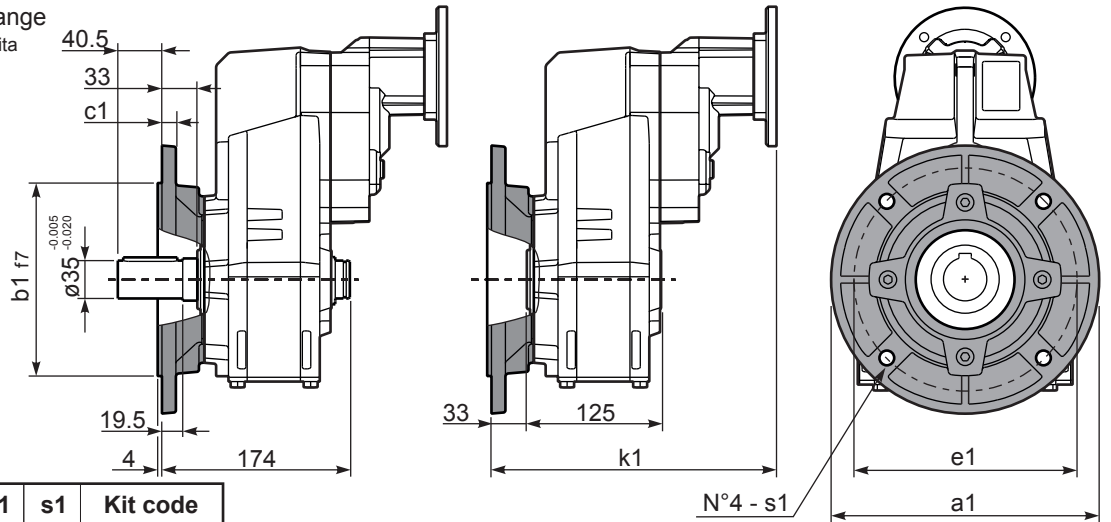

**Available output flanges**  
Flange di uscita

a1 ø	b1	c1	e1	s1	Kit code
250	180	13	215	14	KF60.9.011
300	230	16	265	14	KF60.9.012

**RFA53C...** Input Shaft  
Albero in entrata

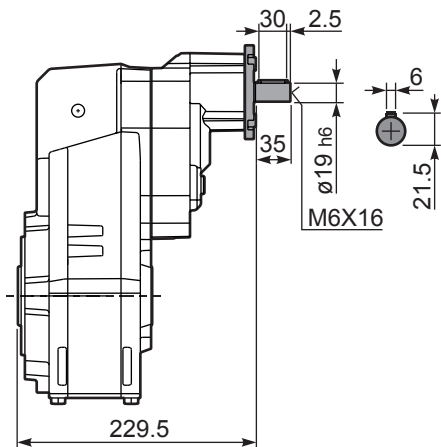

**PFA53 A...** Single output shaft  
Albero uscita semplice

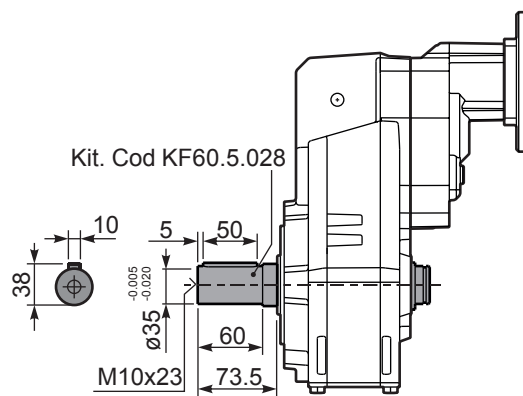

**PFA53D...** Shrink disk  
Calettatore

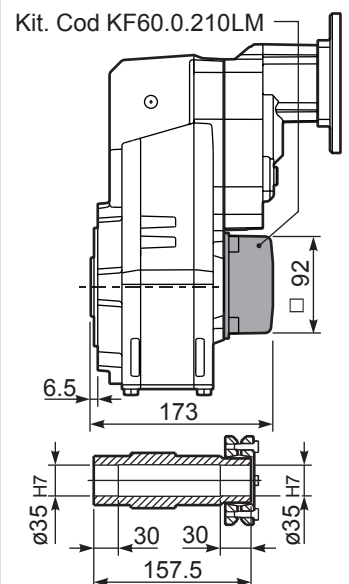





QUICK SELECTION / Selezione veloce							input speed (n <sub>1</sub> ) = 1400 min <sup>-1</sup>								
Output Speed n <sub>2</sub> [min <sup>-1</sup> ]	Ratio i	Motor power P <sub>1M</sub> [kW]	Output torque M <sub>2M</sub> [Nm]	Service factor f.s.	Nominal power P <sub>1R</sub> [kW]	Nominal torque M <sub>2R</sub> [Nm]	Available B5 motor flanges		B14 motor flanges				Output Shaft		
							-G	132	-	-	-	-	-	-	Output Shaft
507	<b>2.76</b>	9	166	1.6	<b>14.4</b>	<b>265</b>	not available		not available				2980	<b>standard</b>	01
395	<b>3.54</b>	9	213	1.3	<b>11.6</b>	<b>275</b>							2485	<b>ø35</b>	02
277	<b>5.06</b>	9	304	1.0	<b>8.6</b>	<b>290</b>							1891		03
241	<b>5.81</b>	7.5	281	1.2	<b>8.5</b>	<b>330</b>							1693	ø40	04
206	<b>6.79</b>	7.5	329	1.2	<b>8.4</b>	<b>380</b>							1495	On request	05

The dynamic efficiency is **0.98** for all ratios

Motor Flanges Available Flange Motore Disponibili    
 B Supplied with Reduction Bushing Fornito con Bussola di Riduzione    
 B) Available on Request without reduction bushing Disponibile a Richiesta senza Bussola di Riduzione    
 C Motor Flange Holes Position Posizione Fori Flangia Motore

**EN** Unit **FC61** is supplied with synthetic oil for lifetime lubrication, no maintenance is necessary. See table 1 for lubrication and recommended quantity. In table 2 please see possible radial loads and axial loads on the gearbox.

**I** Il riduttore **FC61** viene fornito completo di olio sintetico per la lubrificazione permanente e non necessita di alcuna manutenzione. Vedi tab.1 per oli e quantità consigliati. In tab.2 sono presenti i carichi radiali e assiali applicabili al riduttore.

**D** Das Getriebe **FC61** ist mit synthetischem Öl gefüllt und ist lebensdauergeschmiert. In Tabelle 1 ist die Schmiermenge und das empfohlene Schmiermittel angegeben. In Tabelle 2 sind die zulässigen Radial - und Axialbelastungen des Getriebes aufgeführt.

**F** Le réducteur **FC61** est fourni complet avec de l'huile synthétique pour la lubrification permanente et ne nécessite aucun entretien. Voir tableau 1 concernant les huiles et les quantités conseillées. Les charges radiales et axiales applicables au réducteur sont précisées dans le tableau 2.

**E** El reductor tamaño **FC61** se suministra, lubricado de por vida con aceite sintético y no requieren mantenimiento alguna. Ver tabla 1, para cantidades y aceites recomendados. En la tabla 2, se encuentran las cargas radiales y axiales admitidas por el reductor.

Standard supplied	For these mounting position specify in the order or add oil Per queste posizioni specificare in fase d'ordine o aggiungere olio				
H1	H4	H3	H2	H5	H6
2.05 LT	1.25 LT	1.25 LT	1.40 LT	2.05 LT	1.40 LT
AGIP Telium VSF 320			SHELL Omala S4 WE 320		

For all details on lubrication and plugs check our website [tab. 1](#)  
Per maggiori dettagli su lubrificazione e tappi olio vedi il nostro sito web

RADIAL AND AXIAL LOADS								
Output shaft Albero di uscita			$F_{eq} = F_R \cdot \frac{149.5}{X+119.5}$					
n <sub>2</sub>	FA	FR	n <sub>2</sub>	FA	FR	n <sub>2</sub>	FA	FR
300	600	3000	140	720	3600	70	940	4700
250	640	3200	120	740	3700	40	1220	6100
200	690	3460	85	860	4300	15	1300	6500

**On request reinforced bearings to increase loads.**  
A richiesta cuscinetti rinforzati per aumentare i carichi.

tab. 2

**PFC61C...**

Basic gearbox  
Riduttore base

Gearbox weight  
peso riduttore **31.0 kg**

- Available torque arms, see our web site  
Bracci di reazione disponibili, consulta il nostro sito web

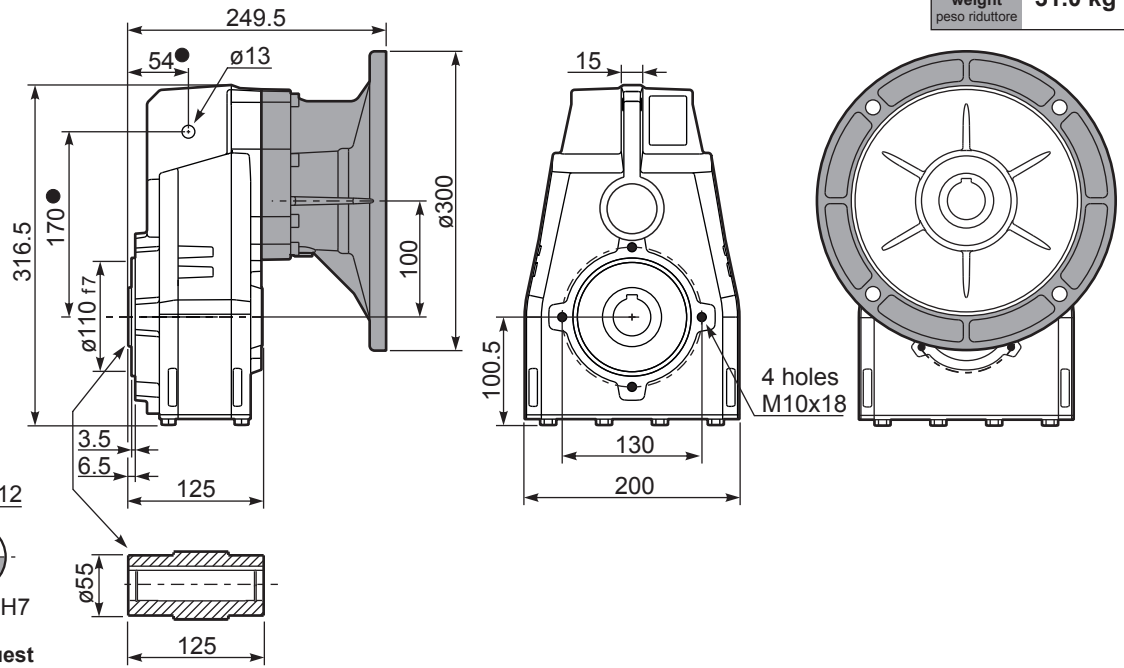

**Standard**  
Hollow shaft

**On request**  
A richiesta

**PFC61...-F...**

Output flange  
Flangia uscita

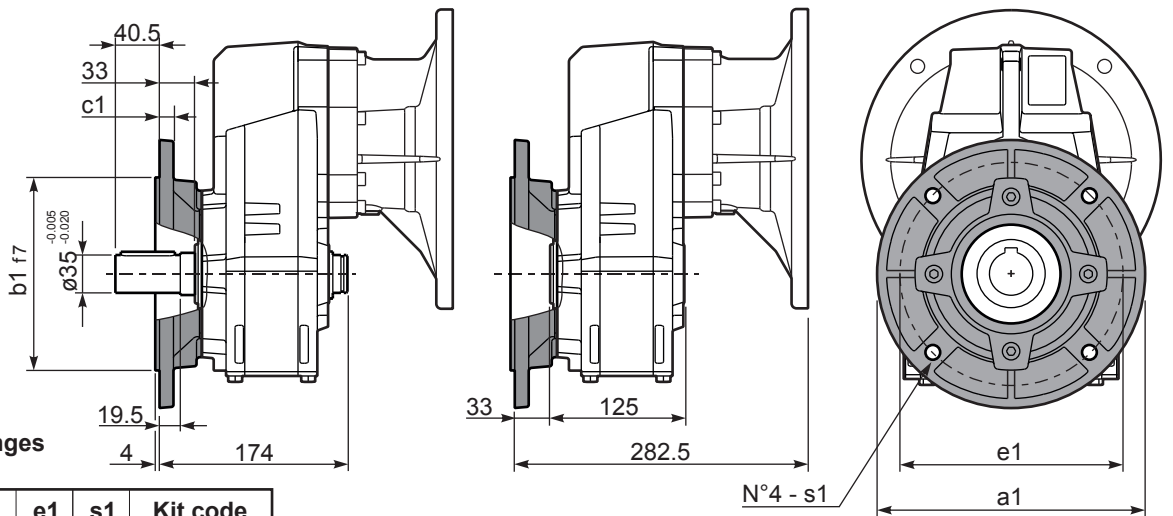

**Available output flanges**  
Flange di uscita

a1 $\phi$	b1	c1	e1	s1	Kit code
250	180	13	215	14	KF60.9.011
300	230	16	265	14	KF60.9.012

**PFC61 A...**

Single output shaft  
Albero uscita semplice

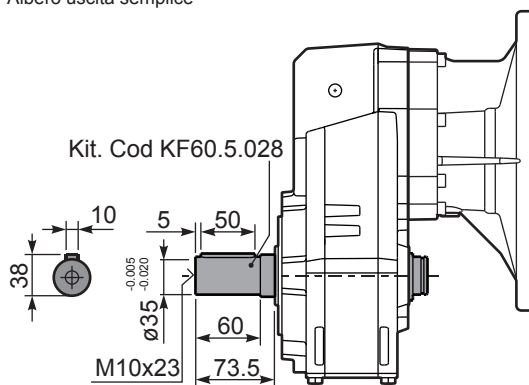



#### QUICK SELECTION / Selezione veloce

input speed ( $n_1$ ) = 1400 min<sup>-1</sup>

Output Speed $n_2$ [min <sup>-1</sup> ]	Ratio $i$	Motor power $P_{1M}$ [kW]	Output torque $M_{2M}$ [Nm]	Service factor $f.s.$	Nominal power $P_{1R}$ [kW]	Nominal torque $M_{2R}$ [Nm]	Available B5 motor flanges					Available B14 motor flanges				Output Shaft 	Ratios code 
							-C	-D	-E	-F	-G	-R	-T	-U	-V		
							71	80	90	100 112	132	80	90	100 112	132		
213	<b>6.57</b>	7.5	312	1.2	8.8	380	B									3018	01
185	<b>7.56</b>	7.5	358	1.1	7.9	390	B									3016	02
159	<b>8.82</b>	7.5	419	1.0	7.1	410	B									3014	03
113	<b>12.39</b>	7.5	588	1.0	7.2	580	B									2018	04
98	<b>14.24</b>	5.5	499	1.2	6.4	600	B									2016	05
84	<b>16.75</b>	5.5	587	1.1	6.1	665	B									1618	06
73	<b>19.25</b>	5.5	675	1.0	5.4	675	B									1616	07
64	<b>21.78</b>	4	558	1.2	4.7	675	B									1318	08
56	<b>25.04</b>	4	642	1.1	4.1	675	B									1316	09
47.9	<b>29.23</b>	4	750	0.9	3.5	675	B									1314	10
45.7	<b>30.65</b>	3	592	1.1	3.4	675	B									1116	11
39.1	<b>35.78</b>	3	691	1.0	2.9	675	B									1114	12
36.3	<b>38.55</b>	2.2	548	1.1	2.3	580	B									818	13
31.6	<b>44.32</b>	2.2	630	1.1	2.3	665	B									816	14
27.1	<b>51.74</b>	2.2	735	0.9	2.0	675	B									814	15
22.9	<b>61.03</b>	1.1	437	1.1	1.2	480	B									616	16
19.6	<b>71.25</b>	1.1	510	1.1	1.2	560	B									614	17

The dynamic efficiency is **0.96** for all ratios

**Motor Flanges Available**  
Flange Motore Disponibili

**B) Supplied with Reduction Bushing**  
Fornito con Bussola di Riduzione

**B) Available on Request without reduction bushing**  
Disponibile a Richiesta senza Bussola di Riduzione

**C) Motor Flange Holes Position**  
Posizione Fori Flangia Motore

**EN** Unit **FC62** is supplied with synthetic oil for lifetime lubrication, no maintenance is necessary. See table 1 for lubrication and recommended quantity. In table 2 please see possible radial loads and axial loads on the gearbox.

**I** Il riduttore **FC62** viene fornito completo di olio sintetico per la lubrificazione permanente e non necessita di alcuna manutenzione. Vedi tab.1 per oli e quantità consigliati. In tab.2 sono presenti i carichi radiali e assiali applicabili al riduttore.

**D** Das Getriebe **FC62** ist mit synthetischem Öl gefüllt und ist lebensdauergeschmiert. In Tabelle 1 ist die Schmiermenge und das empfohlene Schmiermittel angegeben. In Tabelle 2 sind die zulässigen Radial - und Axialbelastungen des Getriebes aufgeführt.

**F** Le réducteur **FC62** est fourni complet avec de l'huile synthétique pour la lubrification permanente et ne nécessite aucun entretien. Voir tableau 1 concernant les huiles et les quantités conseillées. Les charges radiales et axiales applicables au réducteur sont précisées dans le tableau 2.

**E** El reductor tamaño **FC62** se suministra, lubricado de por vida con aceite sintético y no requieren mantenimiento alguna. Ver tabla 1, para cantidades y aceites recomendados. En la tabla 2, se encuentran las cargas radiales y axiales admitidas por el reductor.

Standard supplied	For these mounting position specify in the order or add oil Per queste posizioni specificare in fase d'ordine o aggiungere olio				
2.05 LT	1.25 LT	1.25 LT	1.40 LT	2.20 LT	1.40 LT
AGIP Telium VSF 320			SHELL Omala S4 WE 320		

For all details on lubrication and plugs check our website **tab. 1**  
Per maggiori dettagli su lubrificazione e tappi olio vedi il nostro sito web

### RADIAL AND AXIAL LOADS

**Output shaft**  
Albero di uscita

$F_{eq} = F_R \cdot \frac{149.5}{X+119.5}$

$n_2$	FA	FR	$n_2$	FA	FR	$n_2$	FA	FR
300	600	3000	140	720	3600	70	940	4700
250	640	3200	120	740	3700	40	1220	6100
200	690	3460	85	860	4300	15	1300	6500

**On request reinforced bearings to increase loads.**  
A richiesta cuscinetti rinforzati per aumentare i carichi.

**Input shaft**  
Albero in entrata

$n_1$	FA	FR
1400	450	2250
900	500	2500
500	600	3000

tab. 2

**PFC62C...** Basic gearbox  
Riduttore base

Gearbox weight **20.8 kg**  
peso riduttore

M. flanges	Kit code	øF	A
<b>71B5</b>	K023.4.041	160	227
<b>80/90B5</b>	K023.4.042	200	229
<b>100/112B5</b>	K023.4.043	250	238
<b>132B5</b>	KC50.4.043	300	256
<b>80B14</b>	K085.4.046	120	229
<b>90B14</b>	K085.4.045	140	229
<b>100/112B14</b>	K085.4.047	160	238
<b>132B14</b>	KC50.4.041	200	256

● Available torque arms, see our web site  
Bracci di reazione disponibili, consulta il nostro sito web

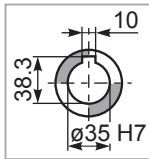

**Standard**  
Hollow shaft

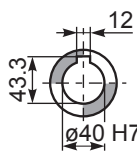

**On request**  
A richiesta

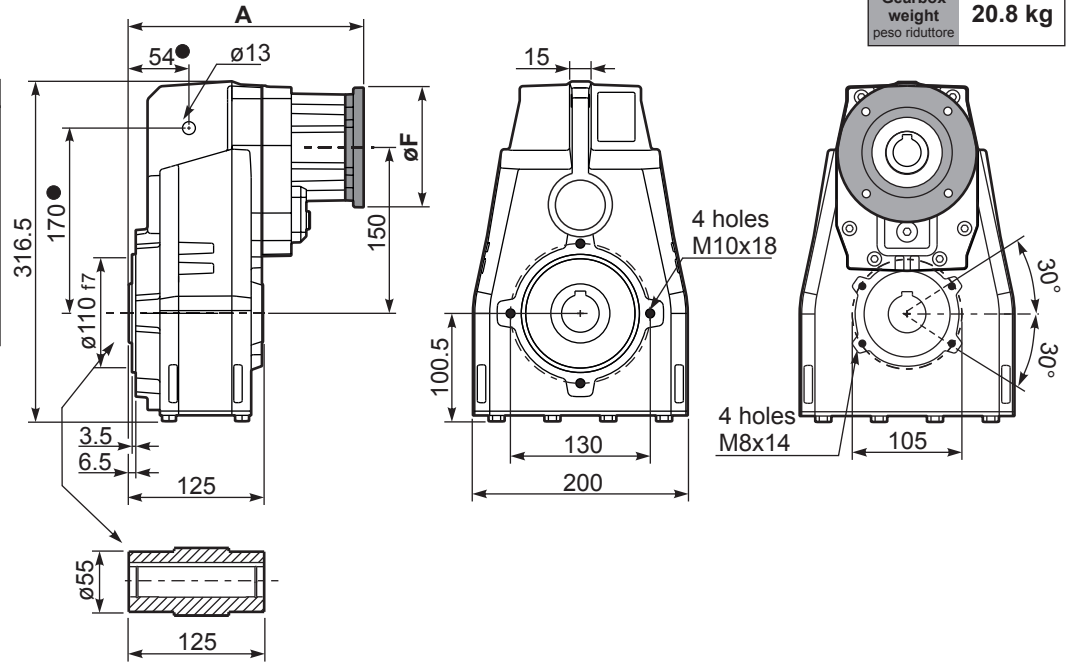

**PFC62...-F...** Output flange  
Flangia uscita

M. flanges	k1
<b>71B5</b>	260
<b>80/90B5</b>	262
<b>100/112B5</b>	268
<b>132B5</b>	289.5
<b>80B14</b>	260
<b>90B14</b>	260
<b>100/112B14</b>	271
<b>132B14</b>	289.5

Available output flanges  
Flange di uscita

a1 ø	b1	c1	e1	s1	Kit code
250	180	13	215	14	KF60.9.011
300	230	16	265	14	KF60.9.012

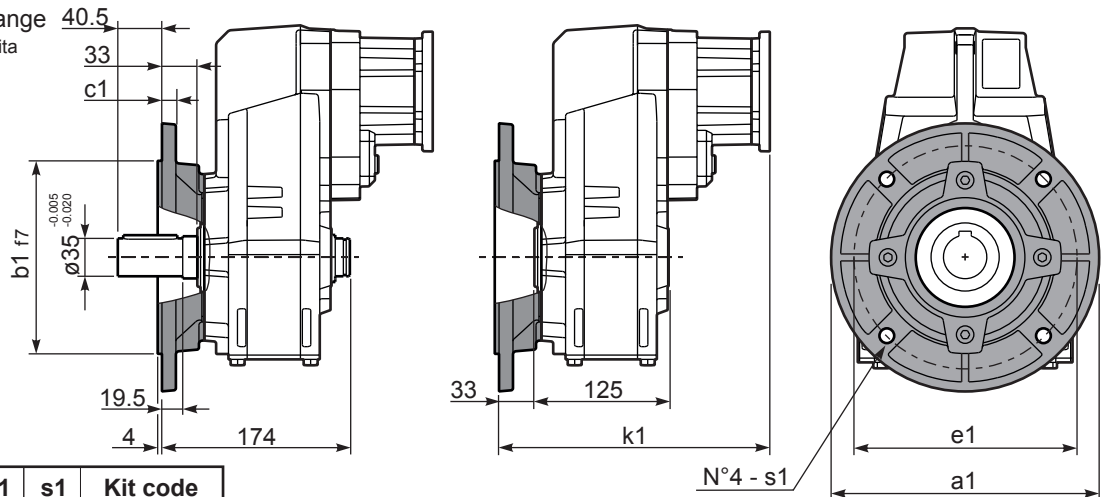

N°4 - s1

**RFC62C...** Input Shaft  
Albero in entrata

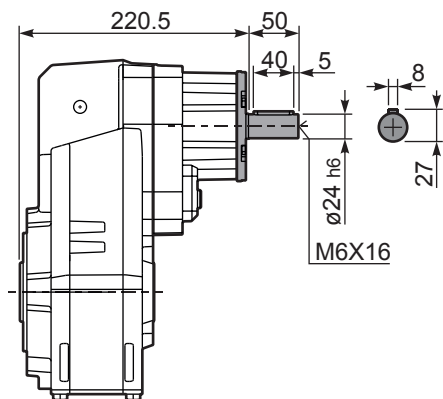

**PFC62 A...** Single output shaft  
Albero uscita semplice

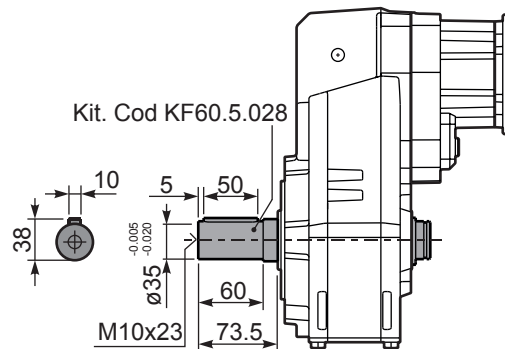

**PFC62D...** Shrink disk  
Calettatore

Kit. Cod KF60.0.210LM

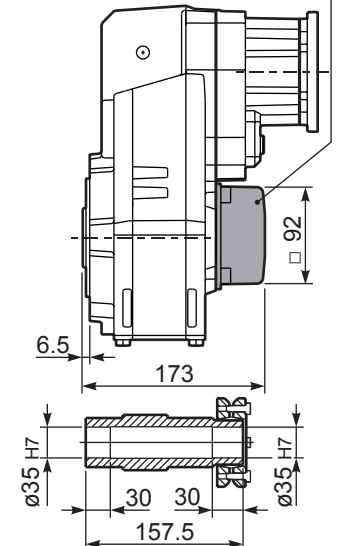



#### QUICK SELECTION / Selezione veloce

input speed ( $n_1$ ) = 1400 min<sup>-1</sup>

Output Speed $n_2$ [min <sup>-1</sup> ]	Ratio $i$	Motor power $P_{1M}$ [kW]	Output torque $M_{2M}$ [Nm]	Service factor $f.s.$	Nominal power $P_{1R}$ [kW]	Nominal torque $M_{2R}$ [Nm]	Available B5 motor flanges				Available B14 motor flanges			Output Shaft 	Ratios code
							-B	-C	-D	-E	-Q	-R	-T		
							63	71	80	90	71	80	90		
22.6	<b>61.89</b>	1.5	594	1.1	1.7	675	B				C	C		191318	01
19.7	<b>71.16</b>	1.5	683	1.0	1.5	675	B				C	C		191316	02
17.0	<b>82.48</b>	1.5	792	0.9	1.3	675	B				C	C		171316	03
14.5	<b>96.29</b>	1.1	675	1.0	1.1	675	B				C	C		171314	04
13.9	<b>100.51</b>	1.1	705	1.0	1.0	675	B				C	C		131318	05
12.1	<b>115.56</b>	0.75	556	1.2	0.91	675	B				C	C		131316	06
11.1	<b>125.96</b>	0.75	606	1.1	0.82	665	B				C	C		190816	07
10.4	<b>134.91</b>	0.75	649	1.0	0.78	675	B				C	C		131314	08
9.5	<b>147.05</b>	0.75	707	1.0	0.72	675	B				C	C		190814	09
8.2	<b>170.44</b>	0.55	605	1.1	0.62	675	B				C	C		170814	10
7.6	<b>184.15</b>	0.55	653	1.0	0.57	675	B				C	C		101314	11
6.8	<b>205.87</b>	0.55	730	0.9	0.51	675	B				C	C		91316	12
5.8	<b>240.34</b>	0.37	570	1.2	0.44	675	B				C	C		91314	13
5.0	<b>279.22</b>	0.37	662	1.0	0.37	665	B				C	C		100816	14
4.3	<b>325.97</b>	0.37	773	0.9	0.32	675	B				C	C		100814	15
3.8	<b>364.41</b>	0.25	583	1.1	0.28	665	B				C	C		90816	16
3.3	<b>425.43</b>	0.25	681	1.0	0.25	675	B				C	C		90814	17
2.9	<b>481.19</b>	0.18	589	1.1	0.22	665	B				C	C		70816	18
2.5	<b>561.76</b>	0.18	687	1.0	0.19	675	B				C	C		70814	19

The dynamic efficiency is **0.94** for all ratios

Motor Flanges Available Flange Motore Disponibili    
 **B) Supplied with Reduction Bushing** Fornito con Bussola di Riduzione    
 **B) Available on Request without reduction bushing** Disponibile a Richiesta senza Bussola di Riduzione    
 **C) Motor Flange Holes Position** Posizione Fori Flangia Motore

**EN** Unit **FC63** is supplied with synthetic oil for lifetime lubrication, no maintenance is necessary. See table 1 for lubrication and recommended quantity. In table 2 please see possible radial loads and axial loads on the gearbox.

**I** Il riduttore **FC63** viene fornito completo di olio sintetico per la lubrificazione permanente e non necessita di alcuna manutenzione. Vedi tab.1 per oli e quantità consigliati. In tab.2 sono presenti i carichi radiali e assiali applicabili al riduttore.

**D** Das Getriebe **FC63** ist mit synthetischem Öl gefüllt und ist lebensdauergeschmiert. In Tabelle 1 ist die Schmiermenge und das empfohlene Schmiermittel angegeben. In Tabelle 2 sind die zulässigen Radial - und Axialbelastungen des Getriebes aufgeführt.

**F** Le réducteur **FC63** est fourni complet avec de l'huile synthétique pour la lubrification permanente et ne nécessite aucun entretien. Voir tableau 1 concernant les huiles et les quantités conseillées. Les charges radiales et axiales applicables au réducteur sont précisées dans le tableau 2.

**E** El reductor tamaño **FC63** se suministra, lubricado de por vida con aceite sintético y no requieren mantenimiento alguna. Ver tabla 1, para cantidades y aceites recomendados. En la tabla 2, se encuentran las cargas radiales y axiales admitidas por el reductor.

Standard supplied	For these mounting position specify in the order or add oil Per queste posizioni specificare in fase d'ordine o aggiungere olio				
2.30 LT	1.35 LT	1.35 LT	1.55 LT	2.45 LT	1.55 LT
AGIP Telium VSF 320			SHELL Omala S4 WE 320		

For all details on lubrication and plugs check our website **tab. 1**  
Per maggiori dettagli su lubrificazione e tappi olio vedi il nostro sito web

### RADIAL AND AXIAL LOADS

**Output shaft**  
Albero di uscita

$F_{eq} = FR \cdot \frac{149.5}{X+119.5}$

**On request reinforced bearings to increase loads.**  
A richiesta cuscinetti rinforzati per aumentare i carichi.

$n_2$	FA	FR	$n_2$	FA	FR	$n_2$	FA	FR
300	600	3000	140	720	3600	70	940	4700
250	640	3200	120	740	3700	40	1220	6100
200	690	3460	85	860	4300	15	1300	6500

**Input shaft**  
Albero in entrata

$n_1$	FA	FR
1400	240	1200
900	280	1400
500	340	1700

tab. 2



**PFC63C...** Basic gearbox  
Riduttore base

Gearbox weight **20.8 kg**  
peso riduttore

M. flanges	Kit code	øF	A
<b>63B5</b>	K063.4.041	140	239
<b>71B5</b>	K063.4.042	160	237
<b>80/90B5</b>	K063.4.043	200	239
<b>71B14</b>	K063.4.047	105	237
<b>80B14</b>	K063.4.046	120	239
<b>90B14</b>	K063.4.041	140	239

● Available torque arms,  
see our web site  
Bracci di reazione disponibili,  
consulta il nostro sito web

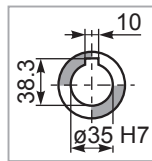

**Standard**  
Hollow shaft

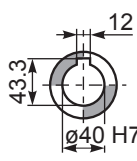

**On request**  
A richiesta

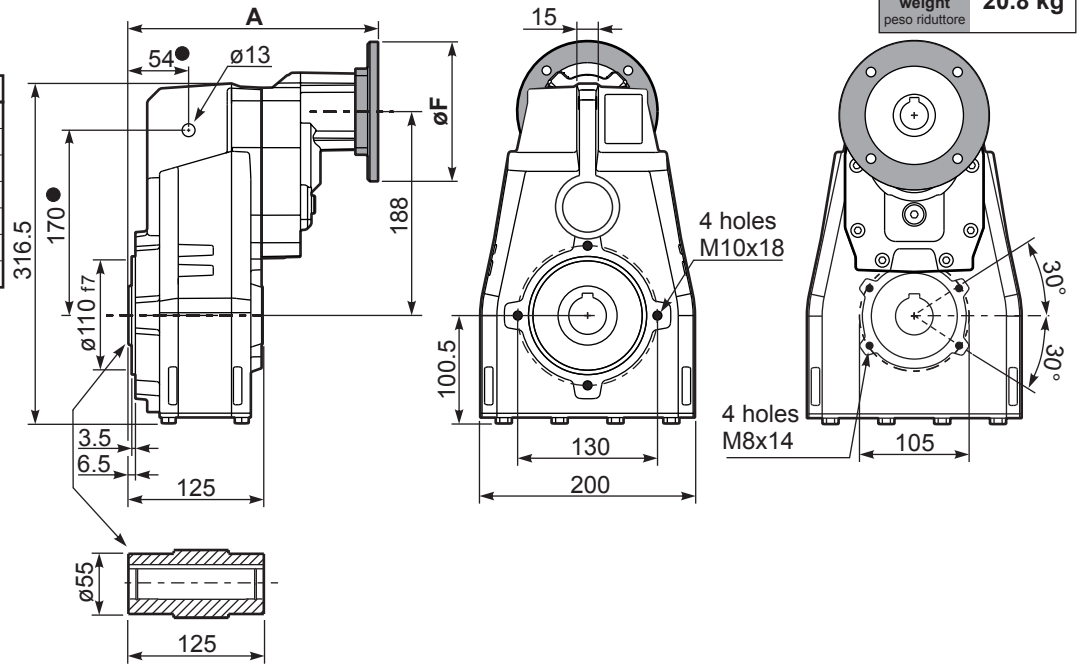

**PFC63...-F...** Output flange  
Flangia uscita

Motor Flange	k1
63B5	272
71B5	270
80/90B5	272
71B14	270
80B14	271
90B14	272

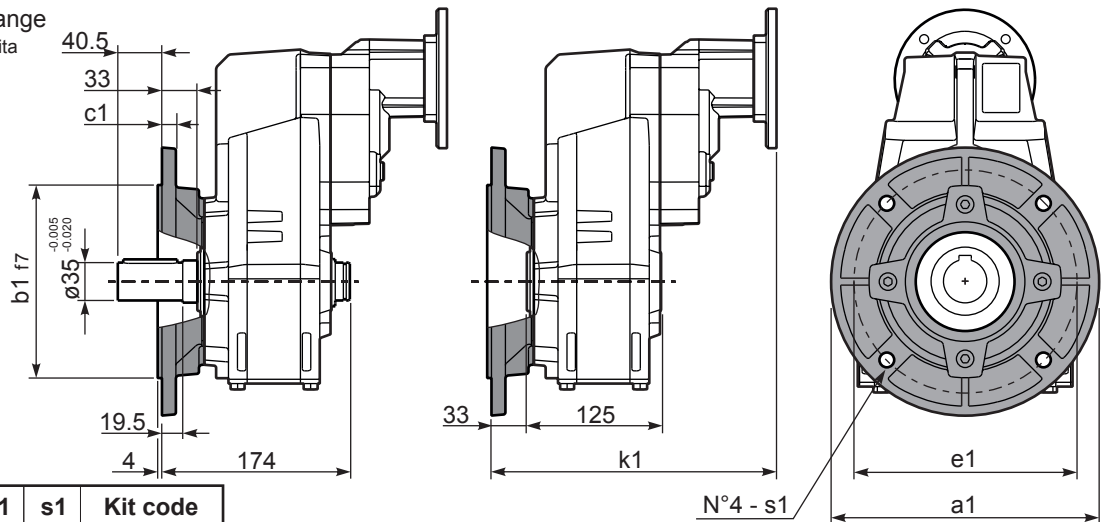

**Available output flanges**  
Flange di uscita

a1 ø	b1	c1	e1	s1	Kit code
250	180	13	215	14	KF60.9.011
300	230	16	265	14	KF60.9.012

**RFC63C...** Input Shaft  
Albero in entrata

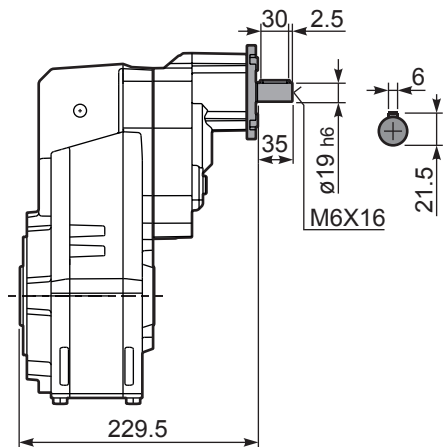

**PFC63 A...** Single output shaft  
Albero uscita semplice

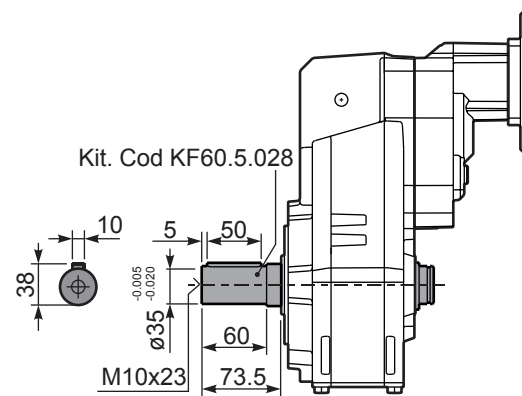

**PFC63 D...** Shrink disk  
Calettatore

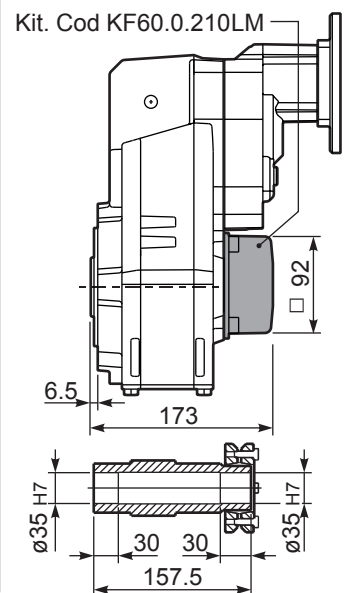





### QUICK SELECTION / Selezione veloce

input speed ( $n_1$ ) = 1400 min<sup>-1</sup>

Output Speed $n_2$ [min <sup>-1</sup> ]	Ratio $i$	Motor power $P_{1M}$ [kW]	Output torque $M_{2M}$ [Nm]	Service factor f.s.	Nominal power $P_{1R}$ [kW]	Nominal torque $M_{2R}$ [Nm]	Available B5 motor flanges		B14 motor flanges				Output Shaft	
							-G	132	-	-	-	-	-	-
227	<b>6.17</b>	9	371	1.2	<b>10.9</b>	<b>450</b>			<b>not available</b>					
198	<b>7.06</b>	9	425	1.4	<b>12.7</b>	<b>600</b>			<b>not available</b>					
170	<b>8.21</b>	9	494	1.4	<b>12.2</b>	<b>670</b>			<b>not available</b>					

The dynamic efficiency is **0.98** for all ratios

**A) Motor Flanges Available**  
Flange Motore Disponibili

**B) Supplied with Reduction Bushing**  
Fornito con Bussola di Riduzione

**B) Available on Request without reduction bushing**  
Disponibile a Richiesta senza Bussola di Riduzione

**C) Motor Flange Holes Position**  
Posizione Fori Flangia Motore

**EN** Unit **FC71** is supplied without lubricant and equipped with a breather, level and drain plugs. User can add mineral oil keeping existing plugs. Should the user wish to fill it with synthetic oil, it is recommended to replace the existing plugs with a closed plug.  
See table 1 for lubrication and recommended quantity.  
In table 2 please see possible radial loads and axial loads on the gearbox.

**I** Il riduttore tipo **FC71** è fornito privo di lubrificazione con tappi di sfiato, livello e scarico olio. L'utente può immettere olio minerale mantenendo i tappi esistenti. Se immetterà olio sintetico, dovrà sostituire i tappi esistenti con altri tipo chiuso.  
Tab.1 per oli e quantità consigliati.  
Tab.2 carichi radiali e assiali applicabili al riduttore.

**D** Das Getriebe der Baugröße **FC71** wird ohne Schmiermittel geliefert. Es ist jedoch mit Einfüllschraube, Überdruckventil und Ablassschraube ausgerüstet. Das benötigte mineralische Öl kann über die Einfüllschraube eingefüllt werden. Sollte synthetisches Öl bevorzugt werden, so ist sind das eingebaute Überdruckventil durch eine geschlossenen Schraube zu ersetzen.  
In Tabelle 1 ist die Schmiermenge und das empfohlene Schmiermittel angegeben.  
In Tabelle 2 sind die zulässigen Radial - und Axialbelastungen des Getriebes aufgeführt.

**F** Le réducteur de type **FC71** est fourni sans lubrification et avec un bouchon de remplissage, de niveau et d'évacuation de l'huile. L'utilisateur peut y verser de l'huile minérale en conservant les bouchons existants. S'il y versera de l'huile synthétique, il devra substituer les bouchons existants avec d'autres bouchons de type fermé.  
Voir tableau 1 concernant les huiles et les quantités conseillées.  
Voir tableau 2 concernant les charges radiales et axiales applicables au réducteur

**E** El reductor tamaño **FC71** se suministra sin lubricante, provisto de tapones de respiración, nivel y descarga de aceite. El usuario puede utilizar aceite mineral, manteniendo los tapones existentes. Si prefiere utilizar aceite sintético deberá sustituir los tapones existentes por tapones ciegos. La prerreducción se suministra con tapones ciegos, lubricado de por vida con aceite sintético. Ver tabla 1, para cantidades y aceites recomendados. En la tabla 2, se encuentran las cargas radiales y axiales admitidas por el reductor.

H1	H4	H3	H2	H5	H6
3.30 LT	1.90 LT	1.90 LT	1.80 LT	3.30 LT	1.90 LT

**AGIP** Blasias 460

For all details on lubrication and plugs check our website **tab. 1**  
Per maggiori dettagli su lubrificazione e tappi olio vedi il nostro sito web

### RADIAL AND AXIAL LOADS

**Output shaft**  
Albero di uscita

$F_{eq} = F_R \cdot \frac{174.5}{X+134.5}$

$n_2$	$F_A$	$F_R$	$n_2$	$F_A$	$F_R$	$n_2$	$F_A$	$F_R$
<b>300</b>	740	3700	<b>140</b>	860	4300	<b>70</b>	1020	5100
<b>250</b>	800	4000	<b>120</b>	900	4500	<b>40</b>	1300	6500
<b>200</b>	830	4150	<b>85</b>	970	4850	<b>15</b>	1700	8500

**On request reinforced bearings to increase loads.**  
A richiesta cuscinetti rinforzati per aumentare i carichi.

**tab. 2**

**PFC71C...** Basic gearbox  
Riduttore base

Gearbox weight  
peso riduttore **35.0 kg**

- Available torque arms, see our web site  
Bracci di reazione disponibili, consulta il nostro sito web

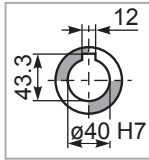

**Standard**  
Hollow shaft

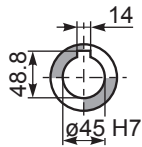

**On request**  
A richiesta

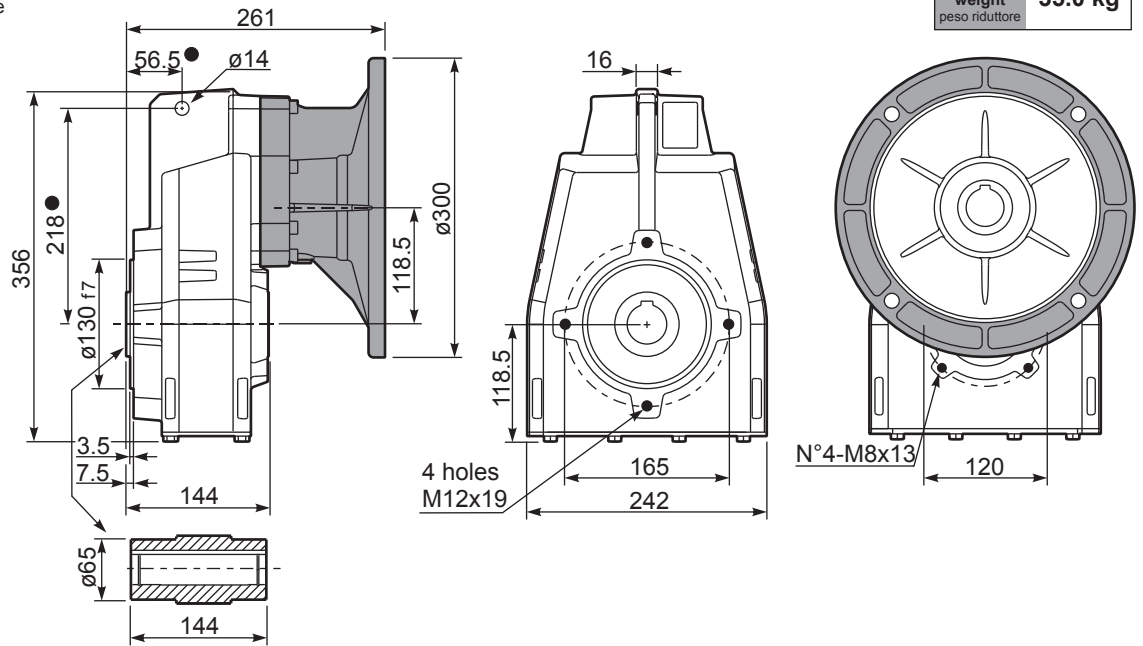

**PFC71...-F...** Output flange  
Flangia uscita

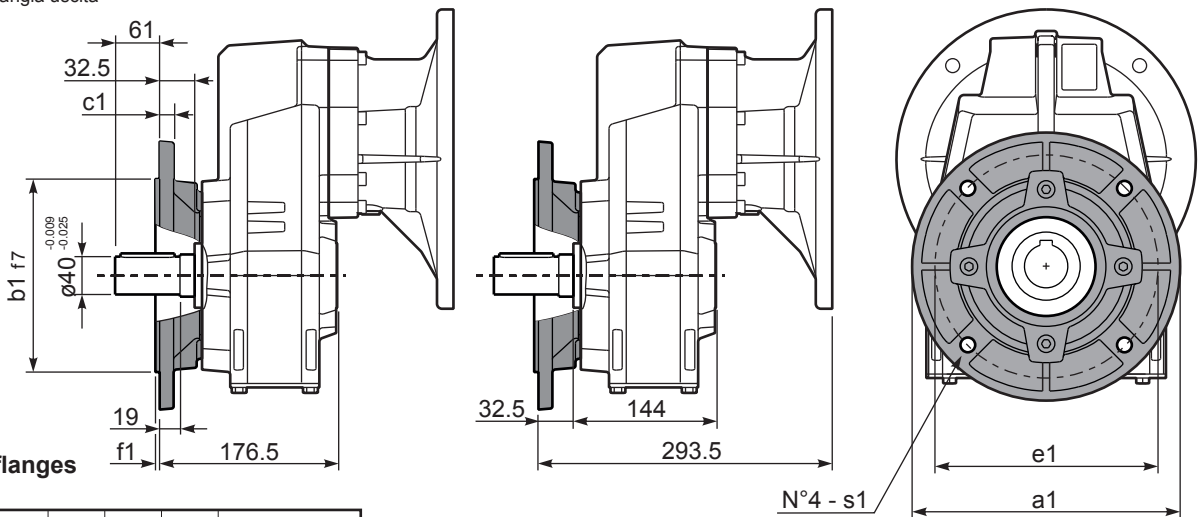

**Available output flanges**  
Flange di uscita

a1	ø	b1	c1	e1	f1	s1	Kit code
250		180	13	215	3	14	KF70.9.011
300		230	16	265	4	14	KF70.9.012
350		250	18	300	4	18	KF70.9.013

**PFC71 A...** Single output shaft  
Albero uscita semplice

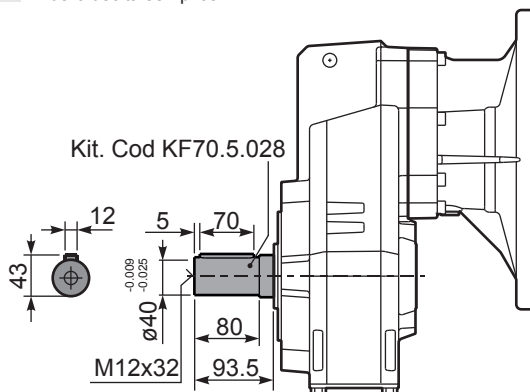

Kit. Cod KF70.5.028



### QUICK SELECTION / Selezione veloce

input speed ( $n_1$ ) = 1400 min<sup>-1</sup>

Output Speed $n_2$ [min <sup>-1</sup> ]	Ratio $i$	Motor power $P_{1M}$ [kW]	Output torque $M_{2M}$ [Nm]	Service factor f.s.	Nominal power $P_{1R}$ [kW]	Nominal torque $M_{2R}$ [Nm]	Available B5 motor flanges					Available B14 motor flanges				Output Shaft 	Ratios code 	
							-C	-D	-E	-F	-G	-R	-T	-U	-V			
							71	80	90	100 112	132	80	90	100 112	132			
175	<b>8.02</b>	9	473	1.1	<b>9.9</b>	<b>520</b>	B										3018	01
152	<b>9.18</b>	9	541	1.1	<b>9.8</b>	<b>590</b>	B										3016	02
131	<b>10.68</b>	9	630	1.1	<b>9.7</b>	<b>680</b>	B										3014	03
93	<b>15.11</b>	7.5	717	1.1	<b>7.8</b>	<b>775</b>	B										2018	04
81	<b>17.30</b>	7.5	821	1.1	<b>7.8</b>	<b>885</b>	B										2016	05
70	<b>20.13</b>	7.5	955	0.9	<b>6.8</b>	<b>900</b>	B										2014	06
60	<b>23.39</b>	5.5	820	1.1	<b>5.9</b>	<b>900</b>	B										1616	07
51	<b>27.21</b>	5.5	954	0.9	<b>5.1</b>	<b>900</b>	B										1614	08
46.0	<b>30.42</b>	4	780	1.2	<b>4.5</b>	<b>900</b>	B										1316	09
39.6	<b>35.38</b>	4	907	1.0	<b>3.9</b>	<b>900</b>	B										1314	10
37.6	<b>37.24</b>	3	719	1.2	<b>3.7</b>	<b>895</b>	B										1116	11
32.3	<b>43.31</b>	3	836	1.1	<b>3.2</b>	<b>900</b>	B										1114	12
29.8	<b>47.02</b>	2.2	668	1.1	<b>2.3</b>	<b>705</b>	B										818	13
26.0	<b>53.85</b>	2.2	765	1.1	<b>2.3</b>	<b>810</b>	B										816	14
22.4	<b>62.63</b>	2.2	890	1.0	<b>2.2</b>	<b>900</b>	B										814	15
18.9	<b>74.16</b>	1.1	531	1.1	<b>1.2</b>	<b>585</b>	B										616	16
16.2	<b>86.25</b>	1.1	617	1.1	<b>1.2</b>	<b>680</b>	B										614	17

The dynamic efficiency is **0.96** for all ratios

**Motor Flanges Available**  
Flange Motore Disponibili

**B) Supplied with Reduction Bushing**  
Fornito con Bussola di Riduzione

**B) Available on Request without reduction bushing**  
Disponibile a Richiesta senza Bussola di Riduzione

**C) Motor Flange Holes Position**  
Posizione Fori Flangia Motore

**EN** Unit **FC72** is supplied without lubricant and equipped with a breather, level and drain plugs. User can add mineral oil keeping existing plugs. Should the user wish to fill it with synthetic oil, it is recommended to replace the existing plugs with a closed plug. See table 1 for lubrication and recommended quantity. In table 2 please see possible radial loads and axial loads on the gearbox.

**I** Il riduttore tipo **FC72** è fornito privo di lubrificazione con tappi di sfiato, livello e scarico olio. L'utente può immettere olio minerale mantenendo i tappi esistenti. Se immetterà olio sintetico, dovrà sostituire i tappi esistenti con altri tipo chiuso. Tab.1 per oli e quantità consigliati. Tab.2 carichi radiali e assiali applicabili al riduttore.

**D** Das Getriebe der Baugröße **FC72** wird ohne Schmiermittel geliefert. Es ist jedoch mit Einfüllschraube, Überdruckventil und Ablassschraube ausgerüstet. Das benötigte mineralische Öl kann über die Einfüllschraube eingefüllt werden. Sollte synthetisches Öl bevorzugt werden, so ist sind das eingebaute Überdruckventil durch eine geschlossenen Schraube zu ersetzen. In Tabelle 1 ist die Schmiermenge und das empfohlene Schmiermittel angegeben. In Tabelle 2 sind die zulässigen Radial - und Axialbelastungen des Getriebes aufgeführt.

**F** Le réducteur de type **FC72** est fourni sans lubrification et avec un bouchon de remplissage, de niveau et d'évacuation de l'huile. L'utilisateur peut y verser de l'huile minérale en conservant les bouchons existants. S'il y versera de l'huile synthétique, il devra substituer les bouchons existants avec d'autres bouchons de type fermé. Voir tableau 1 concernant les huiles et les quantités conseillées. Voir tableau 2 concernant les charges radiales et axiales applicables au réducteur.

**E** El reductor tamaño **FC72** se suministra sin lubricante, provisto de tapones de respiración, nivel y descarga de aceite. El usuario puede utilizar aceite mineral, manteniendo los tapones existentes. Si prefiere utilizar aceite sintético deberá sustituir los tapones existentes por tapones ciegos. La prerreducción se suministra con tapones ciegos, lubricado de por vida con aceite sintético. Ver tabla 1, para cantidades y aceites recomendados. En la tabla 2, se encuentran las cargas radiales y axiales admitidas por el reductor.

H1	H4	H3	H2	H5	H6
3.50 LT	1.90 LT	1.90 LT	1.80 LT	3.60 LT	1.90 LT

**AGIP Blasias 460**

For all details on lubrication and plugs check our website **tab. 1**  
Per maggiori dettagli su lubrificazione e tappi olio vedi il nostro sito web

### RADIAL AND AXIAL LOADS

**Output shaft**  
Albero di uscita

$F_{eq} = F_R \cdot \frac{174.5}{X+134.5}$

$n_2$	FA	FR	$n_2$	FA	FR	$n_2$	FA	FR
300	740	3700	140	860	4300	70	1020	5100
250	800	4000	120	900	4500	40	1300	6500
200	830	4150	85	970	4850	15	1700	8500

**On request reinforced bearings to increase loads.**  
A richiesta cuscinetti rinforzati per aumentare i carichi.

**Input shaft**  
Albero in entrata

$n_1$	FA	FR
1400	450	2250
900	500	2500
500	600	3000

**tab. 2**

**PFC72C...**

Basic gearbox  
Riduttore base

M. flanges	Kit code	øF	A
71B5	K023.4.041	160	238.5
80/90B5	K023.4.042	200	240.5
100/112B5	K023.4.043	250	249.5
132B5	KC50.4.043	300	267.5
80B14	K085.4.046	120	240.5
90B14	K085.4.045	140	240.5
100/112B14	K085.4.047	160	249.5
132B14	KC50.4.041	200	267.5

● Available torque arms,  
see our web site  
Bracci di reazione disponibili,  
consulta il nostro sito web

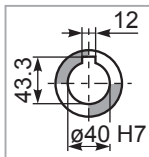

**Standard**  
Hollow shaft

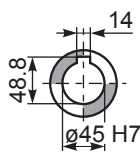

**On request**  
A richiesta

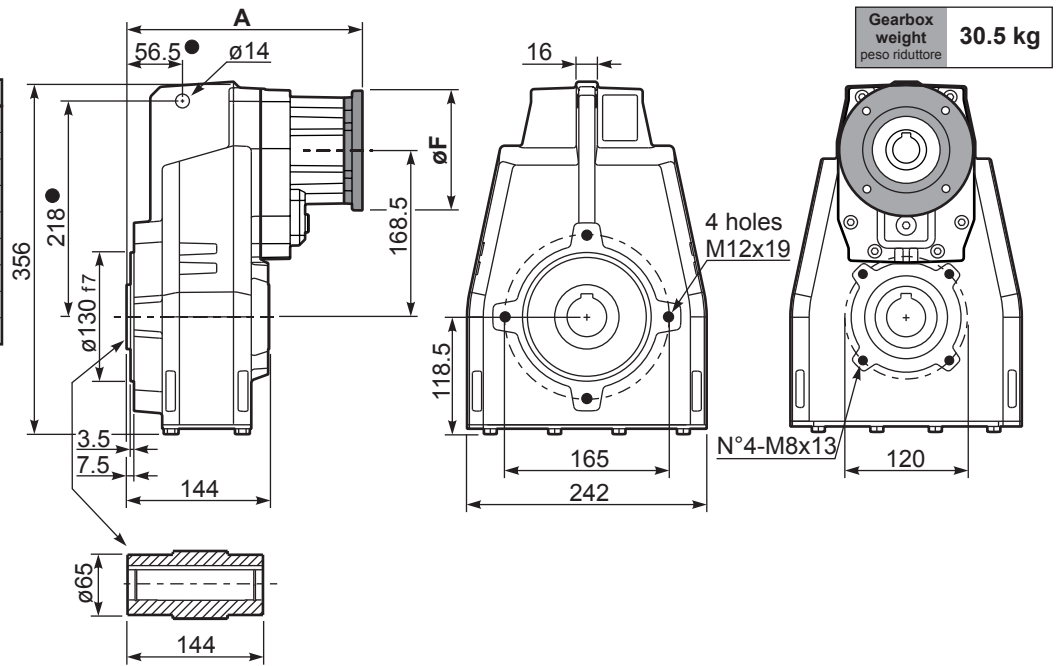

**PFC72...-F...**

Output flange  
Flangia uscita

M. flanges	k1
71B5	271
80/90B5	273
100/112B5	279
132B5	300.5
80B14	271
90B14	271
100/112B14	282
132B14	300.5

Available output flanges  
Flange di uscita

a1 ø	b1	c1	e1	f1	s1	Kit code
250	180	13	215	3	14	KF70.9.011
300	230	16	265	4	14	KF70.9.012
350	250	18	300	4	18	KF70.9.013

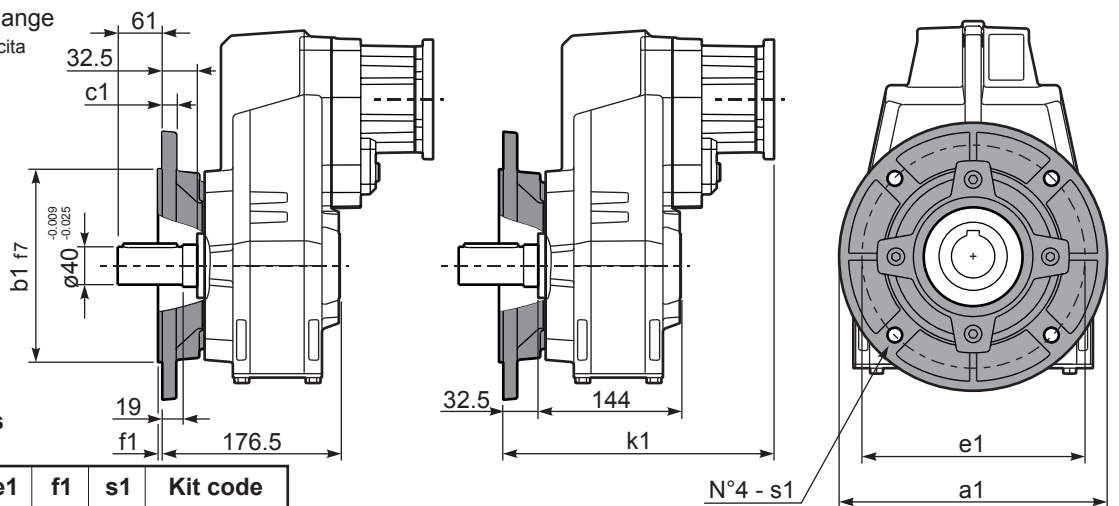

**RFC72C...**

Input Shaft  
Albero in entrata

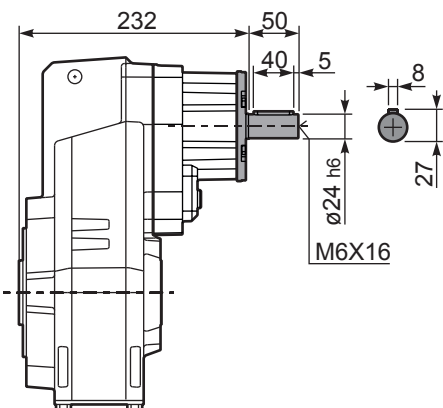

**PFC72 A...**

Single output shaft  
Albero uscita semplice

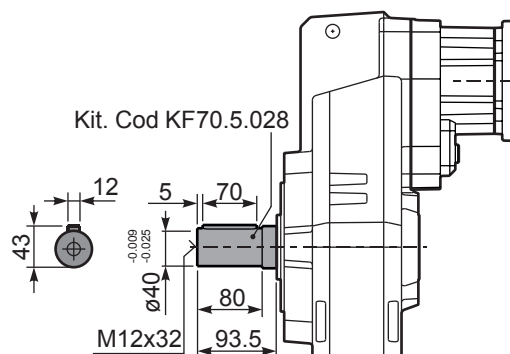

**PFC72D...**

Shrink disk  
Calettatore

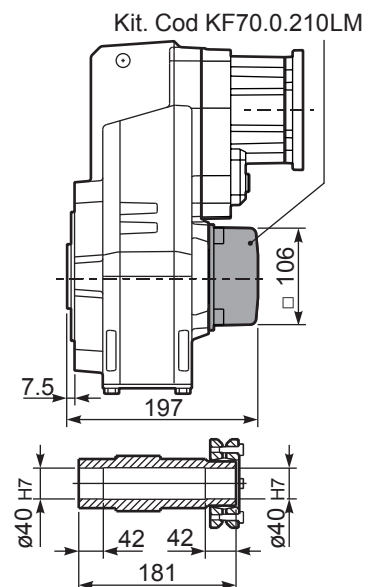



### QUICK SELECTION / Selezione veloce

input speed ( $n_1$ ) = 1400 min<sup>-1</sup>

Output Speed $n_2$ [min <sup>-1</sup> ]	Ratio $i$	Motor power $P_{1M}$ [kW]	Output torque $M_{2M}$ [Nm]	Service factor $f.s.$	Nominal power $P_{1R}$ [kW]	Nominal torque $M_{2R}$ [Nm]	Available B5 motor flanges				Available B14 motor flanges			Output Shaft 	Ratios code
							-B	-C	-D	-E	-Q	-R	-T		
							63	71	80	90	71	80	90		
18.5	<b>75.50</b>	1.5	725	1.1	1.7	825	B				C	C		191318	01
16.2	<b>86.47</b>	1.5	830	1.1	1.6	900	B				C	C		191316	02
14.0	<b>100.22</b>	1.5	962	0.9	1.4	900	B				C	C		171316	03
12.0	<b>116.56</b>	1.1	817	1.1	1.2	900	B				C	C		171314	04
10.2	<b>136.82</b>	1.1	959	0.9	1.0	900	B				C	C		151314	05
9.1	<b>153.05</b>	0.75	736	1.1	0.83	810	B				C	C		190816	06
8.6	<b>163.31</b>	0.75	785	1.1	0.86	900	B				C	C		131314	07
7.9	<b>178.01</b>	0.75	856	1.1	0.79	900	B				C	C		190814	08
7.3	<b>191.67</b>	0.75	922	1.0	0.73	900	B				C	C		101316	09
6.8	<b>206.32</b>	0.75	992	0.9	0.68	900	B				C	C		170814	10
6.3	<b>222.92</b>	0.55	791	1.1	0.63	900	B				C	C		101314	11
5.8	<b>242.18</b>	0.55	859	1.0	0.58	900	B				C	C		150814	12
5.6	<b>250.15</b>	0.55	888	1.0	0.56	900	B				C	C		91316	13
4.8	<b>289.08</b>	0.55	1026	0.9	0.49	900	B				C	C		130814	14
4.2	<b>330.31</b>	0.37	783	1.1	0.42	890	B				C	C		71316	15
3.5	<b>394.59</b>	0.37	936	1.0	0.36	900	B				C	C		100814	16
2.7	<b>514.99</b>	0.25	824	1.1	0.27	900	B				C	C		90814	17
2.1	<b>680.03</b>	0.18	832	1.1	0.21	900	B				C	C		70814	18

The dynamic efficiency is **0.94** for all ratios

**Motor Flanges Available**  
Flange Motore Disponibili

**B) Supplied with Reduction Bushing**  
Fornito con Bussola di Riduzione

**B) Available on Request without reduction bushing**  
Disponibile a Richiesta senza Bussola di Riduzione

**C) Motor Flange Holes Position**  
Posizione Fori Flangia Motore

**EN** Unit FC73 is supplied without lubricant and equipped with a breather, level and drain plugs. User can add mineral oil keeping existing plugs. Should the user wish to fill it with synthetic oil, it is recommended to replace the existing plugs with a closed plug. See table 1 for lubrication and recommended quantity. In table 2 please see possible radial loads and axial loads on the gearbox.

**I** Il riduttore tipo FC73 è fornito privo di lubrificazione con tappi di sfiato, livello e scarico olio. L'utente può immettere olio minerale mantenendo i tappi esistenti. Se immetterà olio sintetico, dovrà sostituire i tappi esistenti con altri tipo chiuso. Tab.1 per oli e quantità consigliati. Tab.2 carichi radiali e assiali applicabili al riduttore.

**D** Das Getriebe der Baugröße FC73 wird ohne Schmiermittel geliefert. Es ist jedoch mit Einfüllschraube, Überdruckventil und Ablaßschraube ausgerüstet. Das benötigte mineralische Öl kann über die Einfüllschraube eingefüllt werden. Sollte synthetisches Öl bevorzugt werden, so ist sind das eingebaute Überdruckventil durch eine geschlossenen Schraube zu ersetzen. In Tabelle 1 ist die Schmiermenge und das empfohlene Schmiermittel angegeben. In Tabelle 2 sind die zulässigen Radial - und Axialbelastungen des Getriebes aufgeführt.

**F** Le réducteur de type FC73 est fourni sans lubrification et avec un bouchon de remplissage, de niveau et d'évacuation de l'huile. L'utilisateur peut y verser de l'huile minérale en conservant les bouchons existants. S'il y versera de l'huile synthétique, il devra substituer les bouchons existants avec d'autres bouchons de type fermé. Voir tableau 1 concernant les huiles et les quantités conseillées. Voir tableau 2 concernant les charges radiales et axiales applicables au réducteur

**E** El reductor tamaño FC73 se suministra sin lubricante, provisto de tapones de respiración, nivel y descarga de aceite. El usuario puede utilizar aceite mineral, manteniendo los tapones existentes. Si prefiere utilizar aceite sintético deberá sustituir los tapones existentes por tapones ciegos. La prerreducción se suministra con tapones ciegos, lubricado de por vida con aceite sintético. Ver tabla 1, para cantidades y aceites recomendados. En la tabla 2, se encuentran las cargas radiales y axiales admitidas por el reductor.

H1	H4	H3	H2	H5	H6
3.55 LT	1.95 LT	1.95 LT	1.95 LT	3.75 LT	2.00 LT

**AGIP** Blasias 460

For all details on lubrication and plugs check our website **tab. 1**  
Per maggiori dettagli su lubrificazione e tappi olio vedi il nostro sito web

### RADIAL AND AXIAL LOADS

**Output shaft**  
Albero di uscita

$F_{eq} = F_R \cdot 174.5$   
 $X + 134.5$

$n_2$	FA	FR	$n_2$	FA	FR	$n_2$	FA	FR
300	740	3700	140	860	4300	70	1020	5100
250	800	4000	120	900	4500	40	1300	6500
200	830	4150	85	970	4850	15	1700	8500

**On request reinforced bearings to increase loads.**  
A richiesta cuscinetti rinforzati per aumentare i carichi.

**Input shaft**  
Albero in entrata

$n_1$	FA	FR
1400	400	2000
900	440	2200
500	440	2200

**tab. 2**



**PFC73C...** Basic gearbox  
Riduttore base

Gearbox weight  
peso riduttore **30.5 kg**

M. flanges	Kit code	øF	A
63B5	K063.4.041	140	250.5
71B5	K063.4.042	160	248.5
80/90B5	K063.4.043	200	250.5
71B14	K063.4.047	105	248.5
80B14	K063.4.046	120	250.5
90B14	K063.4.041	140	250.5

● Available torque arms,  
see our web site  
Bracci di reazione disponibili,  
consulta il nostro sito web

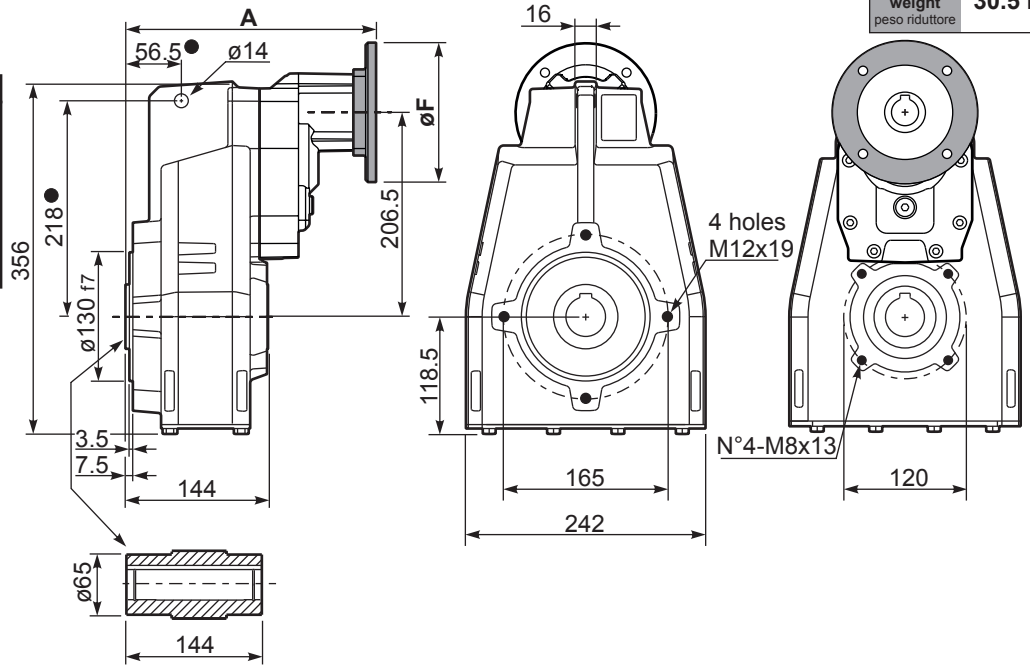
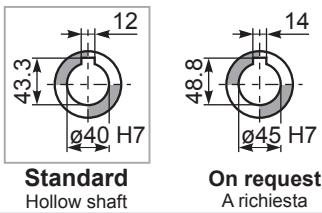

**PFC73...-F...** Output flange  
Flangia uscita

M. flanges	k1
63B5	283
71B5	281
80/90B5	283
71B14	281
80B14	282
90B14	283

Available output flanges  
Flange di uscita

a1 ø	b1	c1	e1	f1	s1	Kit code
250	180	13	215	3	14	KF70.9.011
300	230	16	265	4	14	KF70.9.012
350	250	18	300	4	18	KF70.9.013

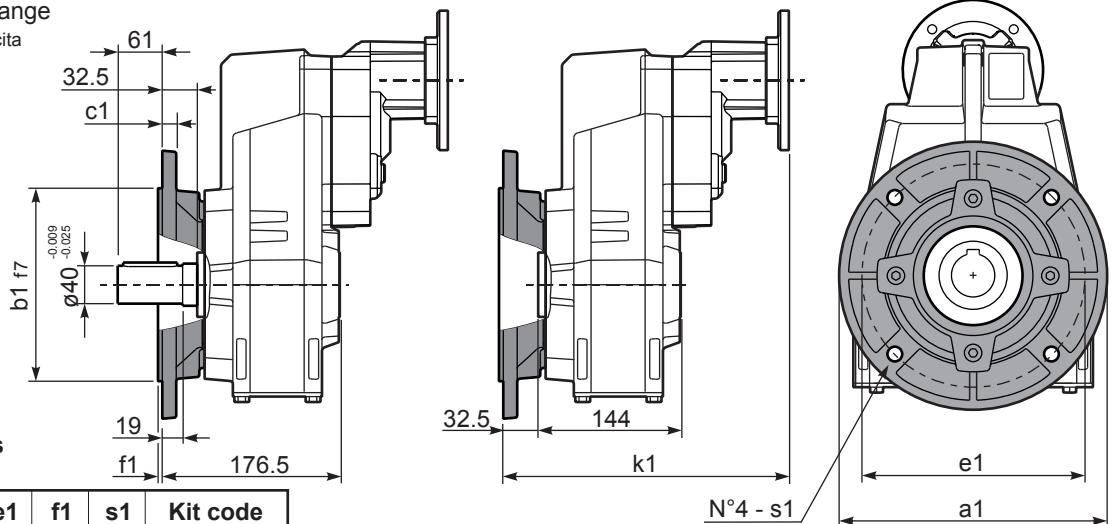

**RFC73C...** Input Shaft  
Albero in entrata

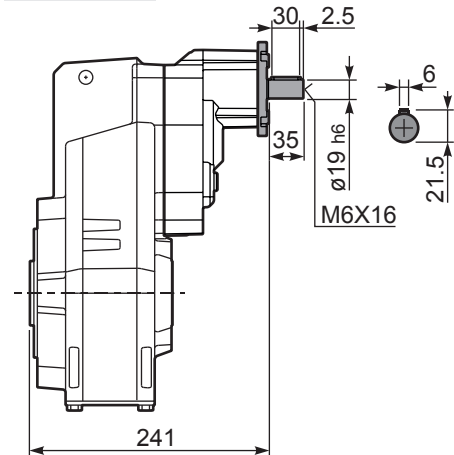

**PFC73 A...** Single output shaft  
Albero uscita semplice

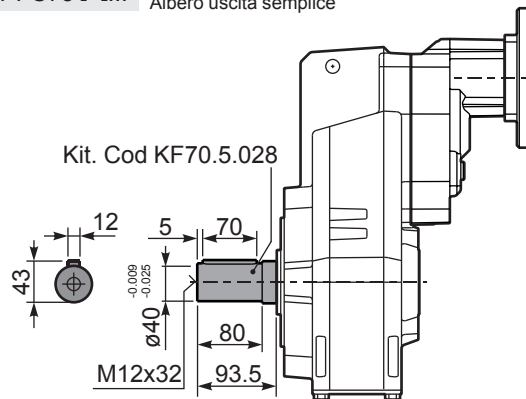

**PFC73D...** Shrink disk  
Calettatore

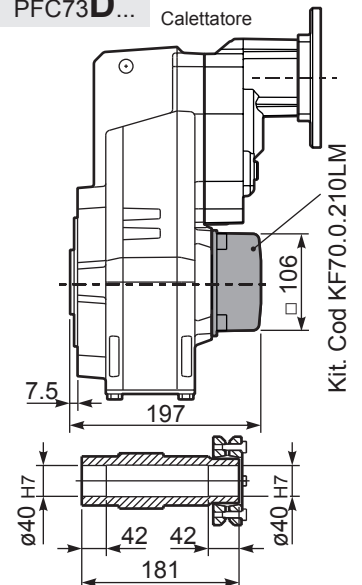





### QUICK SELECTION / Selezione veloce

input speed ( $n_1$ ) = 1400 min<sup>-1</sup>

Output Speed $n_2$ [min <sup>-1</sup> ]	Ratio $i$	Motor power $P_{1M}$ [kW]	Output torque $M_{2M}$ [Nm]	Service factor f.s.	Nominal power $P_{1R}$ [kW]	Nominal torque $M_{2R}$ [Nm]	Available B5 motor flanges		B14 motor flanges				Output Shaft 	Ratios code	
							-H	-I	-	-	-	-			
							160	180	-	-	-	-			
528	<b>2.65</b>	22	374	1.7	<b>36.7</b>	<b>650</b>			<b>not available</b>				2361	<b>standard</b>	01
409	<b>3.42</b>	22	483	1.6	<b>32.8</b>	<b>750</b>							1965	<b>ø50</b>	02
304	<b>4.60</b>	22	649	1.5	<b>30.9</b>	<b>950</b>							1569		03
256	<b>5.46</b>	22	771	1.3	<b>27.4</b>	<b>1000</b>							1371	<b>ø55</b>	04
211	<b>6.64</b>	22	937	1.3	<b>26.5</b>	<b>1175</b>							1173	On request	05

The dynamic efficiency is **0.98** for all ratios

**Motor Flanges Available**  
Flange Motore Disponibili

**B) Supplied with Reduction Bushing**  
Fornito con Bussola di Riduzione

**B) Available on Request without reduction bushing**  
Disponibile a Richiesta senza Bussola di Riduzione

**C) Motor Flange Holes Position**  
Posizione Fori Flangia Motore

**EN** Unit **FC81** is supplied without lubricant and equipped with a breather, level and drain plugs. User can add mineral oil keeping existing plugs. Should the user wish to fill it with synthetic oil, it is recommended to replace the existing plugs with a closed plug. See table 1 for lubrication and recommended quantity. In table 2 please see possible radial loads and axial loads on the gearbox.

**I** Il riduttore tipo **FC81** è fornito privo di lubrificazione con tappi di sfiato, livello e scarico olio. L'utente può immettere olio minerale mantenendo i tappi esistenti. Se immetterà olio sintetico, dovrà sostituire i tappi esistenti con altri tipo chiuso. Tab.1 per oli e quantità consigliati. Tab.2 carichi radiali e assiali applicabili al riduttore.

**D** Das Getriebe der Baugröße **FC81** wird ohne Schmiermittel geliefert. Es ist jedoch mit Einfüllschraube, Überdruckventil und Ablassschraube ausgerüstet. Das benötigte mineralische Öl kann über die Einfüllschraube eingefüllt werden. Sollte synthetisches Öl bevorzugt werden, so ist sind das eingebaute Überdruckventil durch eine geschlossenen Schraube zu ersetzen. In Tabelle 1 ist die Schmiermenge und das empfohlene Schmiermittel angegeben. In Tabelle 2 sind die zulässigen Radial - und Axialbelastungen des Getriebes aufgeführt.

**F** Le réducteur de type **FC81** est fourni sans lubrification et avec un bouchon de remplissage, de niveau et d'évacuation de l'huile. L'utilisateur peut y verser de l'huile minérale en conservant les bouchons existants. S'il y versera de l'huile synthétique, il devra substituer les bouchons existants avec d'autres bouchons de type fermé. Voir tableau 1 concernant les huiles et les quantités conseillées. Voir tableau 2 concernant les charges radiales et axiales applicables au réducteur

**E** El reductor tamaño **FC81** se suministra sin lubricante, provisto de tapones de respiración, nivel y descarga de aceite. El usuario puede utilizar aceite mineral, manteniendo los tapones existentes. Si prefiere utilizar aceite sintético deberá sustituir los tapones existentes por tapones ciegos. La prerreducción se suministra con tapones ciegos, lubricado de por vida con aceite sintético. Ver tabla 1, para cantidades y aceites recomendados. En la tabla 2, se encuentran las cargas radiales y axiales admitidas por el reductor.

H1	H4	H3	H2	H5	H6
5.50 LT	3.50 LT	3.50 LT	3.50 LT	6.20 LT	4.40 LT
<b>AGIP Blasias 460</b>					

For all details on lubrication and plugs check our website **tab. 1**  
Per maggiori dettagli su lubrificazione e tappi olio vedi il nostro sito web

### RADIAL AND AXIAL LOADS

**Output shaft**  
Albero di uscita

$F_{eq} = F_R \cdot \frac{227.5}{X+177.5}$

$n_2$	FA	FR	$n_2$	FA	FR	$n_2$	FA	FR
300	920	4600	140	1120	5600	70	1400	7000
250	1000	5000	120	1140	5700	40	1800	9000
200	1060	5300	85	1300	6500	15	2400	12000

**On request reinforced bearings to increase loads.**  
A richiesta cuscinetti rinforzati per aumentare i carichi.

**tab. 2**

**PFC81C...**

Basic gearbox  
Riduttore base

Gearbox weight  
peso riduttore **78.0 kg**

- Available torque arms, see our web site  
Bracci di reazione disponibili, consulta il nostro sito web

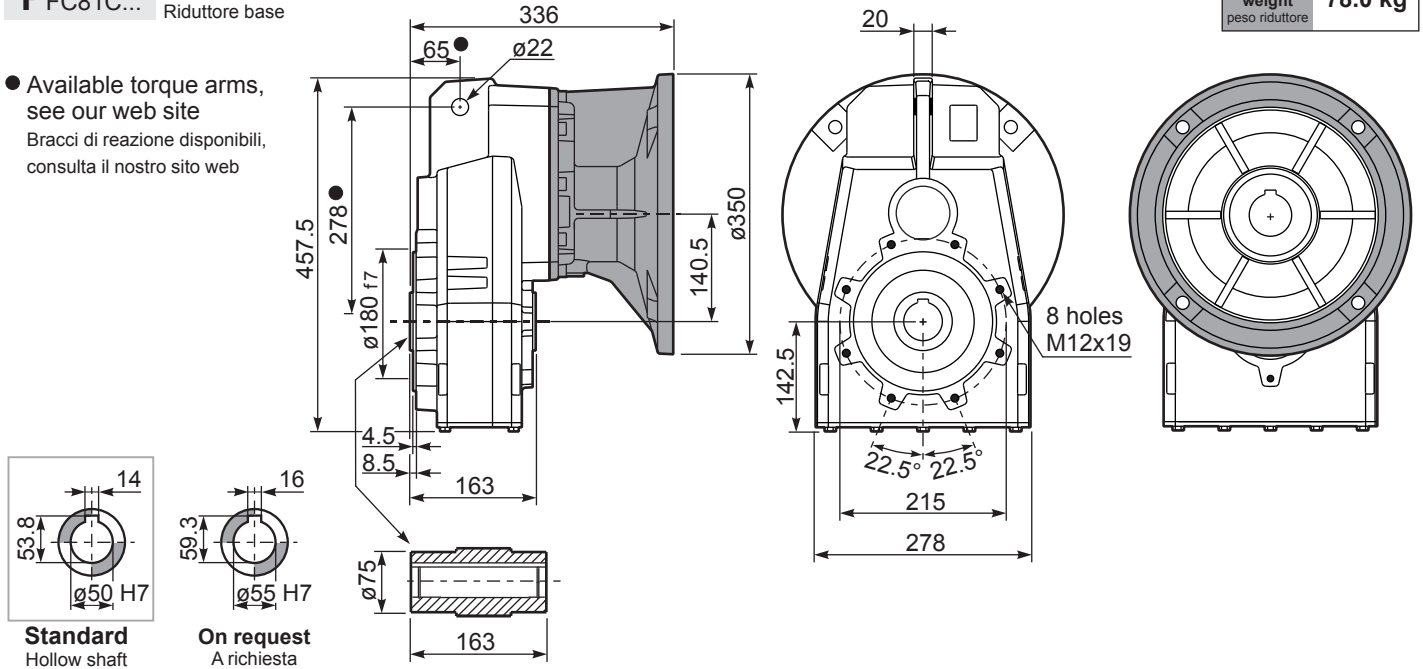

**PFC81...-F...**

Output flange  
Flangia uscita

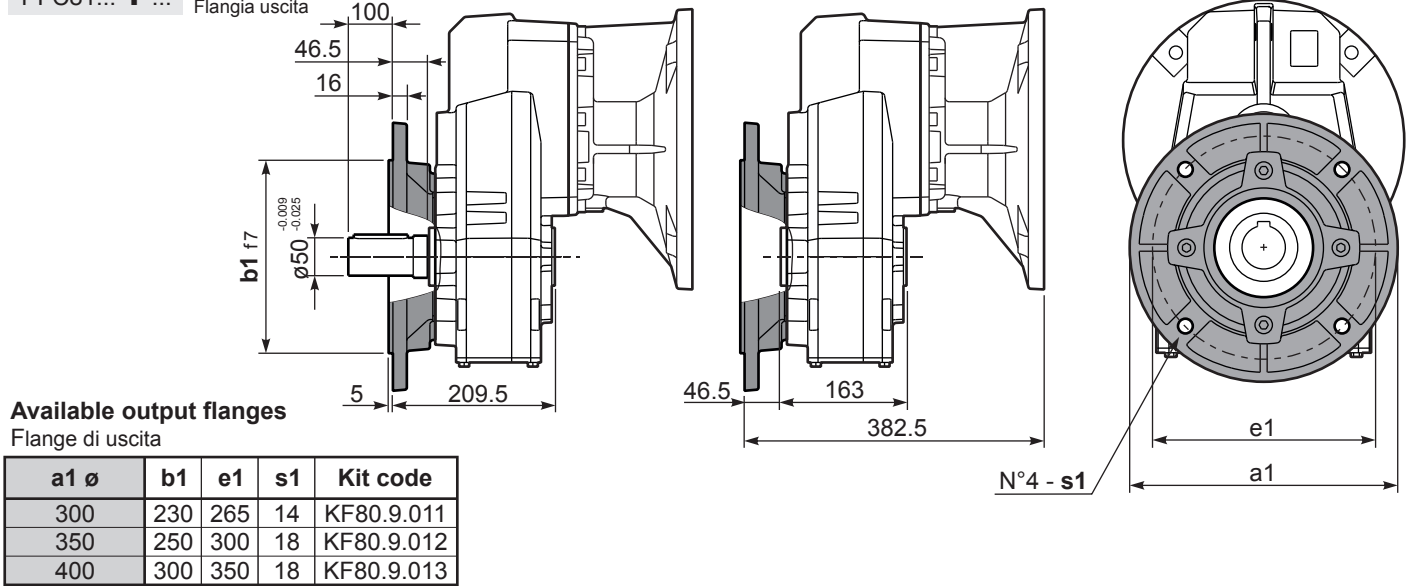

Available output flanges  
Flange di uscita

**PFC81A...**

Single output shaft  
Albero uscita semplice

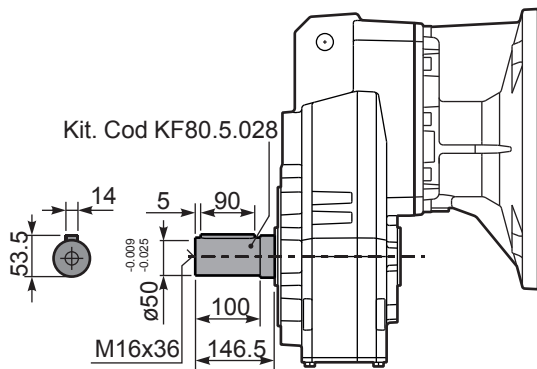



### QUICK SELECTION / Selezione veloce

input speed ( $n_1$ ) = 1400 min<sup>-1</sup>

Output Speed $n_2$ [min <sup>-1</sup> ]	Ratio $i$	Motor power $P_{1M}$ [kW]	Output torque $M_{2M}$ [Nm]	Service factor f.s.	Nominal power $P_{1R}$ [kW]	Nominal torque $M_{2R}$ [Nm]	B5 motor flanges				B14 motor flanges				Output Shaft 	Ratios code 
							-F	-G	-H	-I	-	-	-	-		
							100 112	132	160	180	-	-	-	-		
234	<b>5.98</b>	22	827	1.2	<b>25.5</b>	<b>1000</b>	B							3015	01	
197	<b>7.10</b>	22	982	1.2	<b>25.3</b>	<b>1175</b>	B							3013	02	
162	<b>8.63</b>	22	1193	1.1	<b>23.9</b>	<b>1350</b>	B							3011	03	
124	<b>11.27</b>	18.5	1310	1.1	<b>20.3</b>	<b>1500</b>	B							2015	04	
105	<b>13.38</b>	18.5	1555	1.1	<b>19.4</b>	<b>1700</b>	B							2013	05	
92	<b>15.24</b>	18.5	1771	1.1	<b>19.0</b>	<b>1900</b>	B							1615	06	
86	<b>16.26</b>	18.5	1889	1.1	<b>19.7</b>	<b>2100</b>	B							2011	07	
77	<b>18.09</b>	18.5	2102	1.0	<b>17.7</b>	<b>2100</b>	B							1613	08	
71	<b>19.82</b>	15	1865	1.1	<b>15.9</b>	<b>2060</b>	B							1315	09	
64	<b>21.98</b>	15	2069	1.0	<b>14.6</b>	<b>2100</b>	B							1611	10	
60	<b>23.53</b>	15	2214	0.9	<b>13.6</b>	<b>2100</b>	B							1313	11	
58	<b>24.25</b>	11	1677	1.2	<b>12.2</b>	<b>1940</b>	B							1115	12	
48.6	<b>28.80</b>	11	1991	1.1	<b>11.1</b>	<b>2100</b>	B							1113	13	
40.0	<b>34.99</b>	9	2063	1.0	<b>9.2</b>	<b>2100</b>	B							1111	14	
33.6	<b>41.64</b>	7.5	1976	1.0	<b>7.2</b>	<b>1960</b>	B							813	15	
27.7	<b>50.60</b>	5.5	1774	1.2	<b>6.3</b>	<b>2100</b>	B							811	16	

The dynamic efficiency is **0.96** for all ratios

- Motor Flanges Available Flange Motore Disponibili
- Supplied with Reduction Bushing Fornito con Bussola di Riduzione
- Available on Request without reduction bushing Disponibile a Richiesta senza Bussola di Riduzione
- Motor Flange Holes Position Posizione Fori Flangia Motore

**EN** Unit **FC82** is supplied without lubricant and equipped with a breather, level and drain plugs. User can add mineral oil keeping existing plugs. Should the user wish to fill it with synthetic oil, it is recommended to replace the existing plugs with a closed plug. See table 1 for lubrication and recommended quantity. In table 2 please see possible radial loads and axial loads on the gearbox.

**I** Il riduttore tipo **FC82** è fornito privo di lubrificazione con tappi di sfiato, livello e scarico olio. L'utente può immettere olio minerale mantenendo i tappi esistenti. Se immetterà olio sintetico, dovrà sostituire i tappi esistenti con altri tipo chiuso. Tab.1 per oli e quantità consigliati. Tab.2 carichi radiali e assiali applicabili al riduttore.

**D** Das Getriebe der Baugröße **FC82** wird ohne Schmiermittel geliefert. Es ist jedoch mit Einfüllschraube, Überdruckventil und Ablassschraube ausgerüstet. Das benötigte mineralische Öl kann über die Einfüllschraube eingefüllt werden. Sollte synthetisches Öl bevorzugt werden, so ist sind das eingebaute Überdruckventil durch eine geschlossenen Schraube zu ersetzen. In Tabelle 1 ist die Schmiermenge und das empfohlene Schmiermittel angegeben. In Tabelle 2 sind die zulässigen Radial - und Axialbelastungen des Getriebes aufgeführt.

**F** Le réducteur de type **FC82** est fourni sans lubrification et avec un bouchon de remplissage, de niveau et d'évacuation de l'huile. L'utilisateur peut y verser de l'huile minérale en conservant les bouchons existants. S'il y versera de l'huile synthétique, il devra substituer les bouchons existants avec d'autres bouchons de type fermé. Voir tableau 1 concernant les huiles et les quantités conseillées. Voir tableau 2 concernant les charges radiales et axiales applicables au réducteur

**E** El reductor tamaño **FC82** se suministra sin lubricante, provisto de tapones de respiración, nivel y descarga de aceite. El usuario puede utilizar aceite mineral, manteniendo los tapones existentes. Si prefiere utilizar aceite sintético deberá sustituir los tapones existentes por tapones ciegos. La prerreducción se suministra con tapones ciegos, lubricado de por vida con aceite sintético. Ver tabla 1, para cantidades y aceites recomendados. En la tabla 2, se encuentran las cargas radiales y axiales admitidas por el reductor.

H1	H4	H3	H2	H5	H6
5.70 LT	3.60 LT	3.60 LT	3.60 LT	6.60 LT	4.50 LT

**AGIP** Blasias 460

For all details on lubrication and plugs check our website [tab. 1](#)  
Per maggiori dettagli su lubrificazione e tappi olio vedi il nostro sito web

### RADIAL AND AXIAL LOADS

**Output shaft**  
Albero di uscita

$F_{eq} = F_R \cdot \frac{227.5}{X+177.5}$

**Input shaft**  
Albero in entrata

$n_2$	FA	FR
300	920	4600
250	1000	5000
200	1060	5300

$n_2$	FA	FR
140	1120	5600
120	1140	5700
85	1300	6500

$n_2$	FA	FR
70	1400	7000
40	1800	9000
15	2400	12000

**On request reinforced bearings to increase loads.**  
A richiesta cuscinetti rinforzati per aumentare i carichi.

$n_1$	FA	FR
1400	700	3500
900	840	4200
500	900	4500

tab. 2

**PFC82C...** Basic gearbox  
Riduttore base

Gearbox weight **82.5 kg**  
peso riduttore

M. flanges	Kit code	øF	A
100/112B5	-	250	337.5
132B5	-	300	341.5
160/180B5	-	350	352.5

● Available torque arms, see our web site  
Bracci di reazione disponibili, consulta il nostro sito web

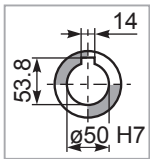

**Standard**  
Hollow shaft

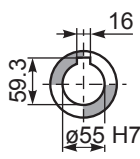

**On request**  
A richiesta

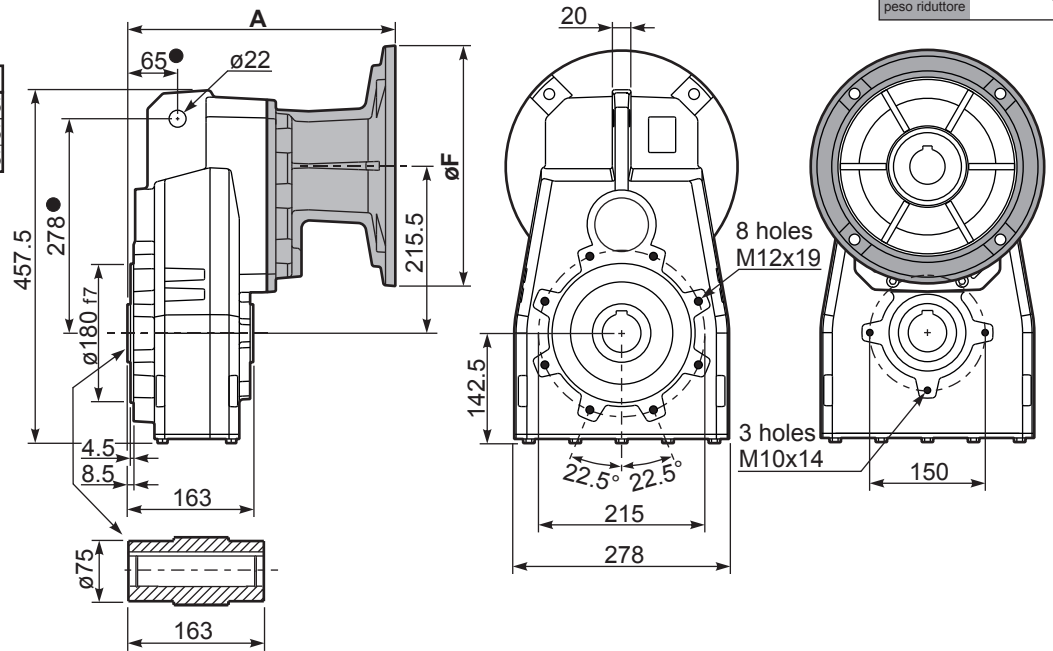

**PFC82...-F...** Output flange  
Flangia uscita

M. flanges	k1
132B5	388
160/180B5	399

Available output flanges  
Flange di uscita

a1 ø	b1	e1	s1	Kit code
300	230	265	14	KF80.9.011
350	250	300	18	KF80.9.012
400	300	350	18	KF80.9.013

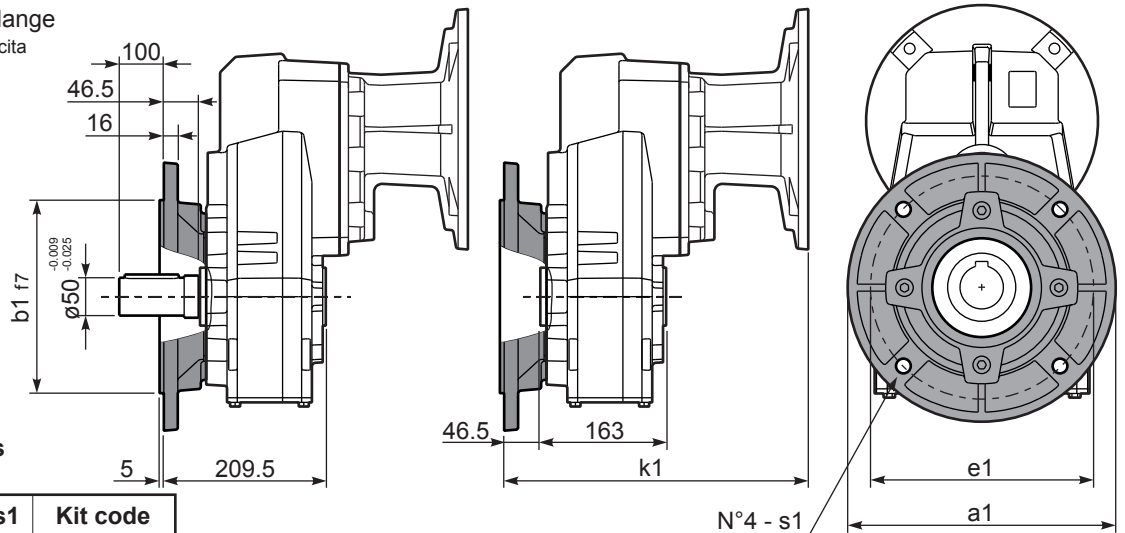

**RFC82C...** Input Shaft  
Albero in entrata

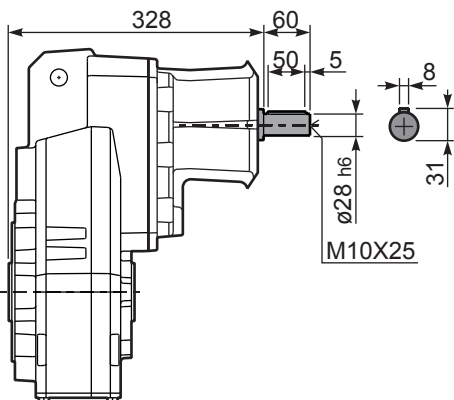

**PFC82 A...** Single output shaft  
Albero uscita semplice

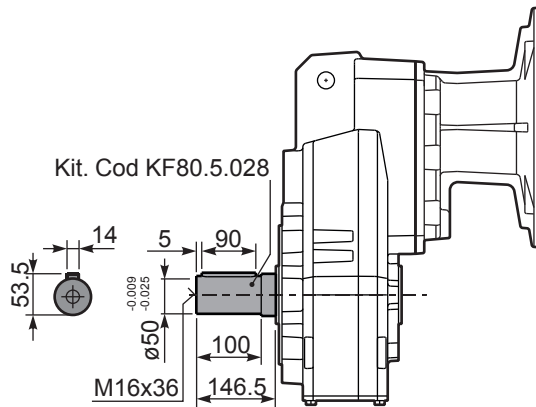

**PFC82 D...** Shrink disk  
Calettatore

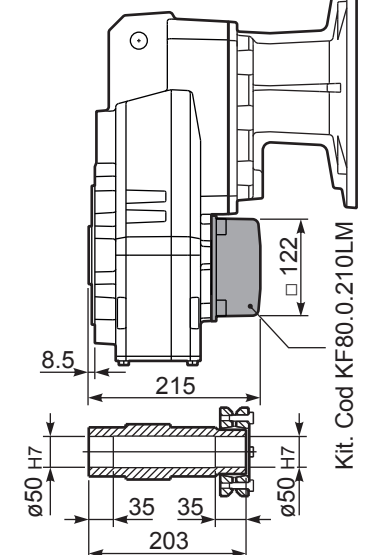



### QUICK SELECTION / Selezione veloce

input speed ( $n_1$ ) = 1400 min<sup>-1</sup>

Output Speed $n_2$ [min <sup>-1</sup> ]	Ratio $i$	Motor power $P_{1M}$ [kW]	Output torque $M_{2M}$ [Nm]	Service factor f.s.	Nominal power $P_{1R}$ [kW]	Nominal torque $M_{2R}$ [Nm]	Available B5 motor flanges					Available B14 motor flanges				Output Shaft 	Ratios code
							-C	-D	-E	-F	-G	-R	-T	-U	-V		
							71	80	90	100 112	132	80	90	100 112	132		
28.8	<b>48.55</b>	7.5	2257	0.9	6.7	2100	B									201315	01
24.3	<b>57.64</b>	5.5	1980	1.1	5.7	2100	B									201313	02
21.3	<b>65.64</b>	5.5	2255	0.9	5.0	2100	B									161315	03
20.0	<b>70.04</b>	4	1760	1.2	4.7	2100	B									201311	04
18.0	<b>77.93</b>	4	1958	1.1	4.2	2100	B									161313	05
16.4	<b>85.36</b>	4	2145	1.0	3.8	2100	B									131315	06
14.8	<b>94.70</b>	4	2380	0.9	3.5	2100	B									161311	07
13.8	<b>101.35</b>	3	1917	1.1	3.2	2100	B									131313	08
11.4	<b>123.15</b>	3	2330	0.9	2.7	2100	B									131311	09
9.3	<b>150.73</b>	2.2	2100	1.0	2.2	2100	B									111311	10
7.8	<b>179.39</b>	1.5	1722	1.2	1.8	2100	B									81313	11
6.4	<b>217.98</b>	1.5	2093	1.0	1.5	2100	B									81311	12
5.7	<b>247.03</b>	1.1	1732	1.1	1.2	1950	B									61313	13
4.7	<b>300.17</b>	1.1	2105	1.0	1.1	2100	B									61311	14

The dynamic efficiency is **0.94** for all ratios

**Motor Flanges Available**  
Flange Motore Disponibili

**B) Supplied with Reduction Bushing**  
Fornito con Bussola di Riduzione

**B) Available on Request without reduction bushing**  
Disponibile a Richiesta senza Bussola di Riduzione

**C) Motor Flange Holes Position**  
Posizione Fori Flangia Motore

**EN** Unit **FC83** is supplied without lubricant and equipped with a breather, level and drain plugs. User can add mineral oil keeping existing plugs. Should the user wish to fill it with synthetic oil, it is recommended to replace the existing plugs with a closed plug. See table 1 for lubrication and recommended quantity. In table 2 please see possible radial loads and axial loads on the gearbox.

**I** Il riduttore tipo **FC83** è fornito privo di lubrificazione con tappi di sfiato, livello e scarico olio. L'utente può immettere olio minerale mantenendo i tappi esistenti. Se immetterà olio sintetico, dovrà sostituire i tappi esistenti con altri tipo chiuso. Tab.1 per oli e quantità consigliati. Tab.2 carichi radiali e assiali applicabili al riduttore.

**D** Das Getriebe der Baugröße **FC83** wird ohne Schmiermittel geliefert. Es ist jedoch mit Einfüllschraube, Überdruckventil und Ablassschraube ausgerüstet. Das benötigte mineralische Öl kann über die Einfüllschraube eingefüllt werden. Sollte synthetisches Öl bevorzugt werden, so ist sind das eingebaute Überdruckventil durch eine geschlossenen Schraube zu ersetzen. In Tabelle 1 ist die Schmiermenge und das empfohlene Schmiermittel angegeben. In Tabelle 2 sind die zulässigen Radial - und Axialbelastungen des Getriebes aufgeführt.

**F** Le réducteur de type **FC83** est fourni sans lubrification et avec un bouchon de remplissage, de niveau et d'évacuation de l'huile. L'utilisateur peut y verser de l'huile minérale en conservant les bouchons existants. S'il y versera de l'huile synthétique, il devra substituer les bouchons existants avec d'autres bouchons de type fermé. Voir tableau 1 concernant les huiles et les quantités conseillées. Voir tableau 2 concernant les charges radiales et axiales applicables au réducteur

**E** El reductor tamaño **FC83** se suministra sin lubricante, provisto de tapones de respiración, nivel y descarga de aceite. El usuario puede utilizar aceite mineral, manteniendo los tapones existentes. Si prefiere utilizar aceite sintético deberá sustituir los tapones existentes por tapones ciegos. La prerreducción se suministra con tapones ciegos, lubricado de por vida con aceite sintético. Ver tabla 1, para cantidades y aceites recomendados. En la tabla 2, se encuentran las cargas radiales y axiales admitidas por el reductor.

H1	H4	H3	H2	H5	H6
5.80 LT	3.90 LT	3.90 LT	3.90 LT	6.80 LT	4.90 LT

**AGIP** Blasias 460

For all details on lubrication and plugs check our website **tab. 1**  
Per maggiori dettagli su lubrificazione e tappi olio vedi il nostro sito web

### RADIAL AND AXIAL LOADS

**Output shaft**  
Albero di uscita

$F_{eq} = F_R \cdot \frac{227.5}{X+177.5}$

$n_2$	FA	FR	$n_2$	FA	FR	$n_2$	FA	FR
300	920	4600	140	1120	5600	70	1400	7000
250	1000	5000	120	1140	5700	40	1800	9000
200	1060	5300	85	1300	6500	15	2400	12000

**On request reinforced bearings to increase loads.**  
A richiesta cuscinetti rinforzati per aumentare i carichi.

**Input shaft**  
Albero in entrata

$n_1$	FA	FR
1400	450	2250
900	500	2500
500	600	3000

**tab. 2**



**PFC83C...**

Basic gearbox  
Riduttore base

Gearbox weight **68.5 kg**  
peso riduttore

M. flanges	Kit code	øF	A
71B5	K023.4.041	160	292.5
80/90B5	K023.4.042	200	294.5
100/112B5	K023.4.043	250	303.5
132B5	KC50.4.043	300	321.5
80B14	K085.4.046	120	294.5
90B14	K085.4.045	140	294.5
100/112B14	K085.4.047	160	303.5
132B14	KC50.4.041	200	321.5

● Available torque arms,  
see our web site  
Bracci di reazione disponibili,  
consulta il nostro sito web

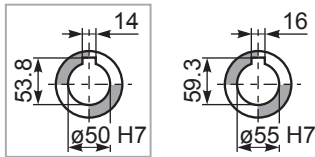

**Standard**  
Hollow shaft

**On request**  
A richiesta

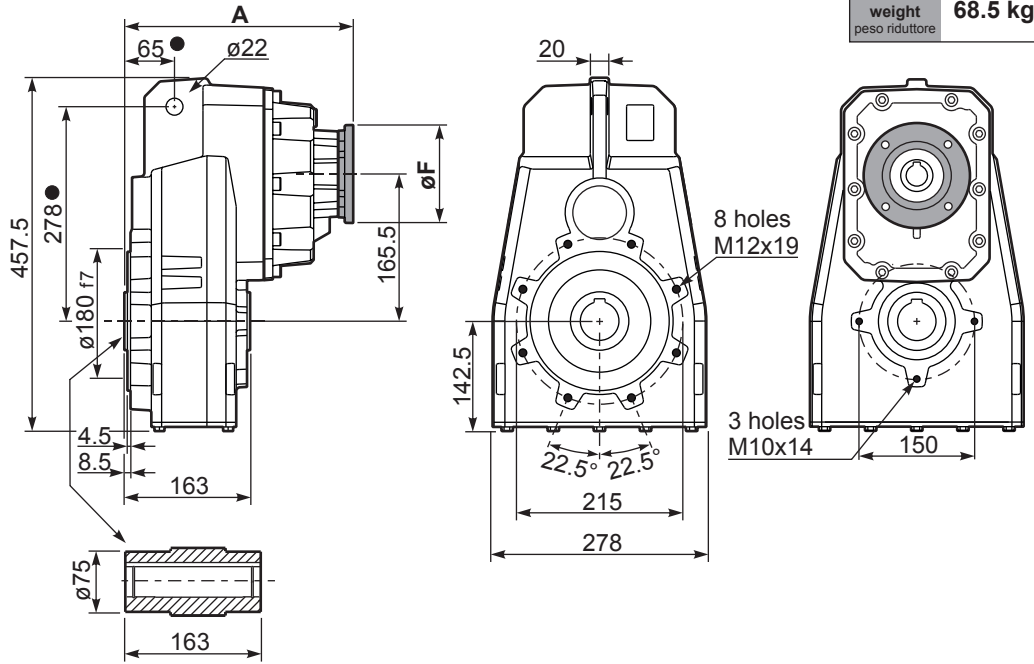

**PFC83...-F...**

Output flange  
Flangia uscita

M. flanges	k1
71B5	339
80/90B5	341
100/112B5	347
132B5	368.5
80B14	339
90B14	339
100/112B14	350
132B14	368.5

Available output flanges  
Flange di uscita

a1 ø	b1	e1	s1	Kit code
300	230	265	14	KF80.9.011
350	250	300	18	KF80.9.012
400	300	350	18	KF80.9.013

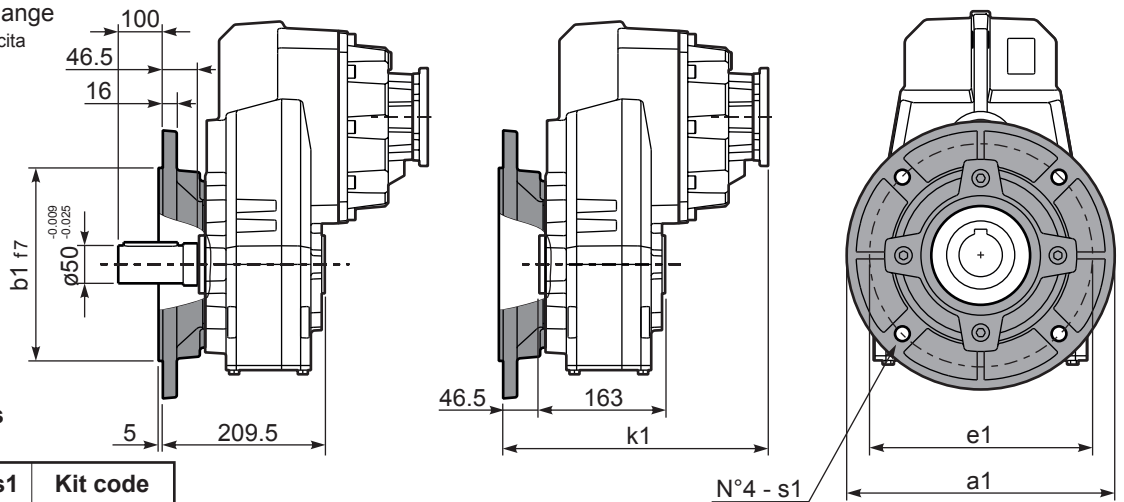

**RFC83C...**

Input Shaft  
Albero in entrata

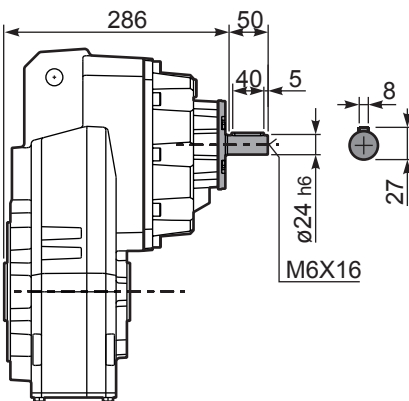

**PFC83 A...**

Single output shaft  
Albero uscita semplice

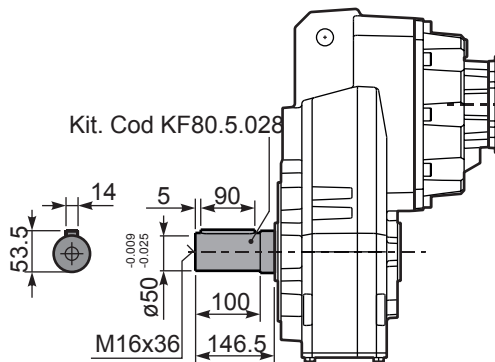

**PFC83D...**

Shrink disk  
Calettatore

Kit. Cod KF80.0.210LM

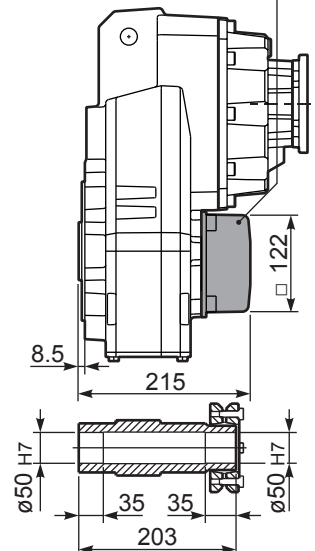



# Cast iron parallel shaft gearboxes

A modular and compact product

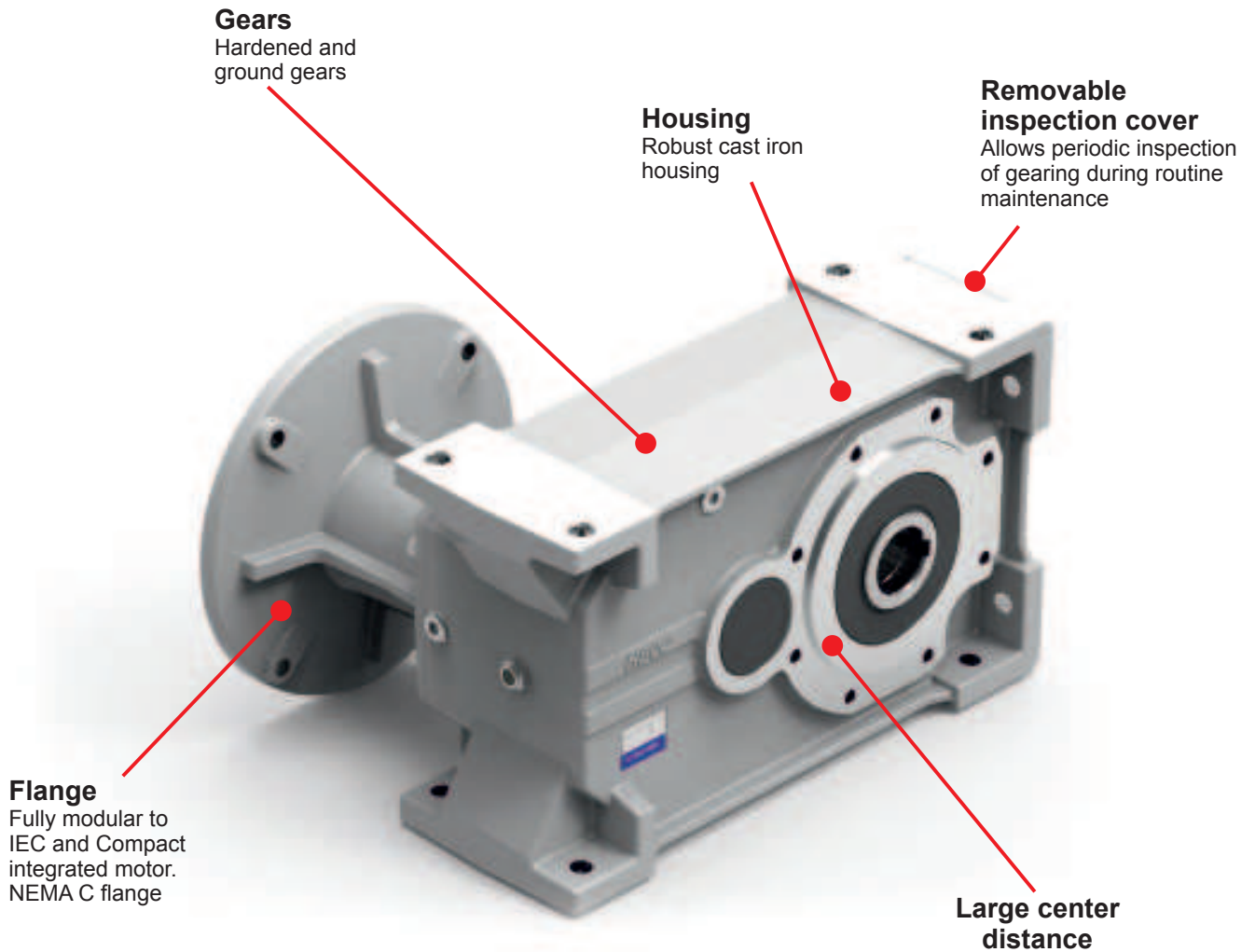

## Single-piece Cast Iron housing

with high tensile strength. Precision machined for alignment of bearings and gearing

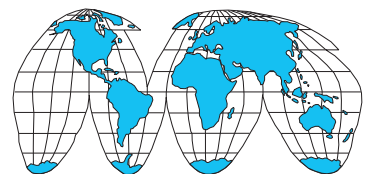
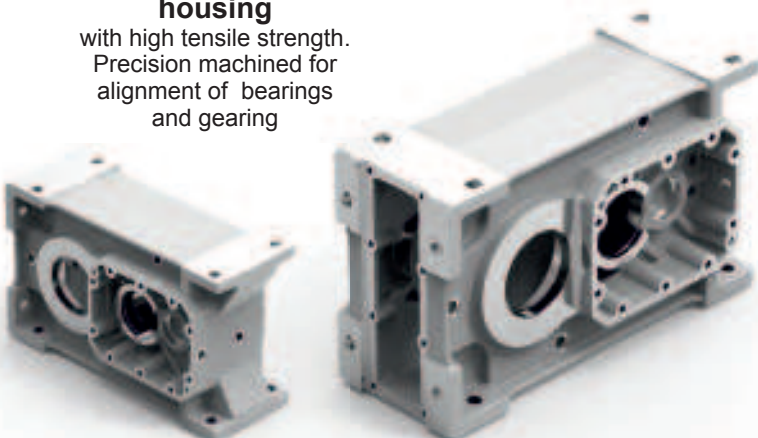

World wide sales network.

# Specific type datasheet on page...

On page / A pagina / Auf Seite / À la page / En la página

1 Stage

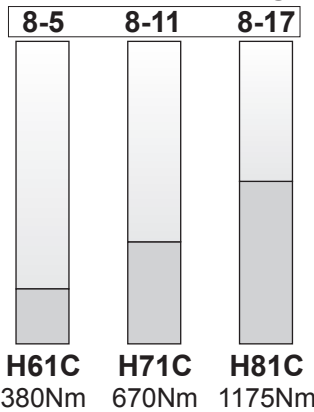
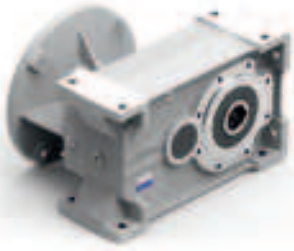

Types / Tipi /  
Tipen / Types /  
Tipos

On page / A pagina / Auf Seite / À la page / En la página

2 and 3 Stage

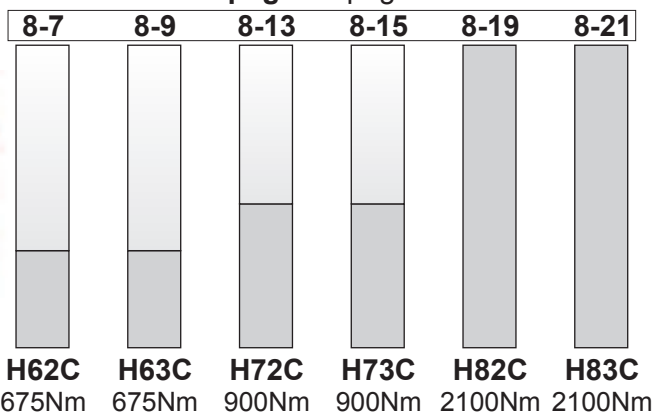

Types / Tipi /  
Tipen / Types /  
Tipos

On page / A pagina / Auf Seite / À la page / En la página

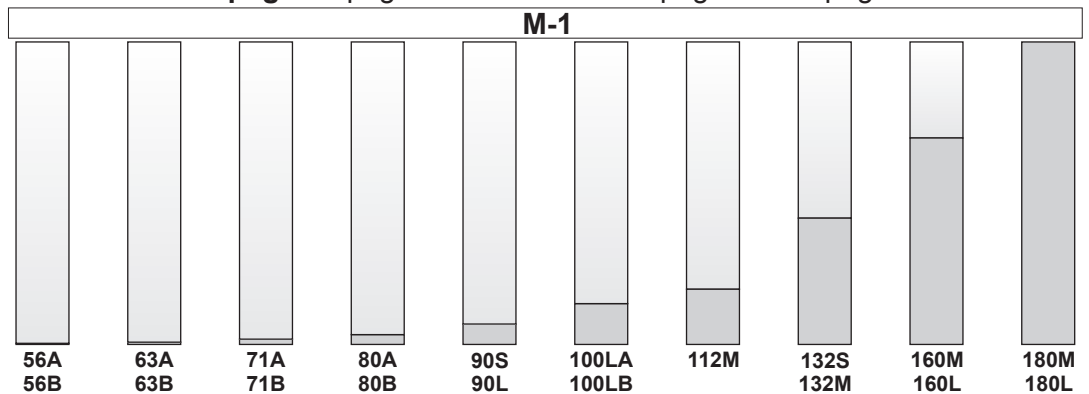



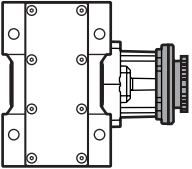
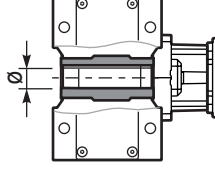
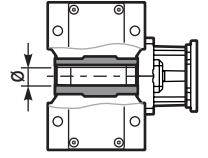
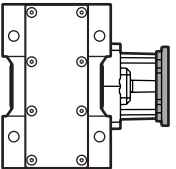
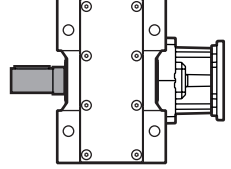
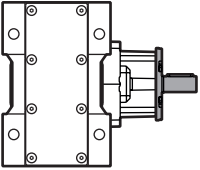
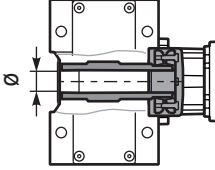
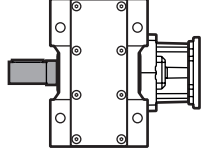
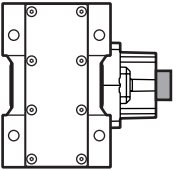
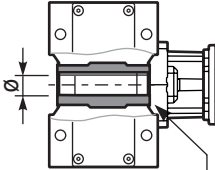
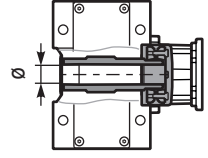





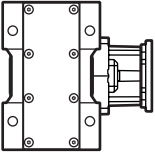
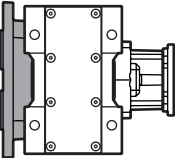

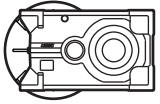

Types / Tipi /  
Tipen / Types /  
Tipos

Type - Tipo - Typ Type - Tipo	Size - Grandezza - Grösse Taille - Tomaño	Mounting - Montaggio Montage - Fixation Tipo de montaje	Rapporto - Ratio Untersetzung Reduction - Relacion	Output shaft Albero uscita Abtriebswelle Arbre de sortie Eje en salida
<b>M</b>	<b>H62C</b>	<b>C</b>	<b>12.39</b>	<b>-E</b>
<p>Parallel shaft helical Riduttori ad assi paralleli</p>  <p>With IEC motor <b>M</b></p>	<p>1 Stage Riduzione Stufe Trains Etapas</p> <p>2 Stages Riduzioni Stufen Trains Etapas</p> <p>3 Stages Riduzioni Stufen Trains Etapas</p> <p>Cast Iron/Ghisa/Grauguss/Fonfe/Fundicion</p>	 <p>Hollow output shaft <b>C</b></p>	<p>See technical data table</p> <p>Vedi tabelle dati tecnici.</p> <p>Technisches Datenblatt beachten</p> <p>Voir Tableau données techniques</p> <p>Ver tabla datos técnicos</p>	 <p><b>STANDARD</b> ⇒ Only on request for Q.ty A richiesta per quantità</p>
 <p>With motor flange <b>P</b></p>	<p><b>H61C</b> <b>H71C</b> <b>H81C</b></p> <p><b>H62C</b> <b>H72C</b> <b>H82C</b></p> <p><b>H63C</b> <b>H73C</b> <b>H83C</b></p>	 <p>Single output shaft <b>A</b></p>		<p>H61C H62C H63C <b>-E</b> ⇒ <math>\varnothing 35</math> <b>-F</b> ⇒ <math>\varnothing 40</math></p> <p>H71C H72C H73C <b>-F</b> ⇒ <math>\varnothing 40</math> <b>-G</b> ⇒ <math>\varnothing 45</math></p> <p>H81C H82C H83C <b>-H</b> ⇒ <math>\varnothing 50</math> <b>-I</b> ⇒ <math>\varnothing 55</math></p>
 <p>With male input shaft <b>R</b></p>		 <p>Shrink Disk <b>D</b></p> <p>Only on request for Q.ty A richiesta per quantità</p>		 <p>Single output shaft</p> <p><b>-N</b> H61/2/3C ⇒ <math>\varnothing 35</math> <b>-O</b> H71/2/3C ⇒ <math>\varnothing 40</math> <b>-K</b> H81/2/3C ⇒ <math>\varnothing 50</math></p>
 <p>Modular base <b>B</b></p> <p>Not available for: H61C, H71C, H81C, H82C</p>		 <p>Stainless steel hub <b>I</b></p> <p>On request for q.ty</p> <p>Stainless steel hub Mozzo in acciaio Inox Edelstahlhohlwelle Moyeu en acier Inox Nucleo corona de acero Inox</p>		 <p>Shrink disk</p> <p><b>-T</b> H62/3C ⇒ <math>\varnothing 35</math> <b>-U</b> H72/3C ⇒ <math>\varnothing 40</math> <b>-V</b> H82/3C ⇒ <math>\varnothing 50</math></p>

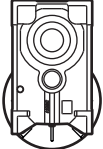
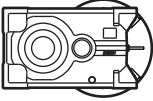
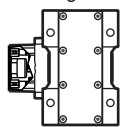
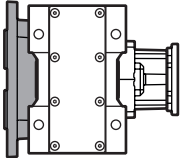

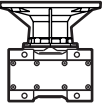
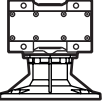
On request we can deliver our products according to the ATEX  
 A richiesta possiamo fornire i nostri prodotti secondo le normative ATEX  
 Auf Anfrage können wir unsere Produkte den Richtlinien ATEX entsprechend liefern  
 Sur demande nos produits peuvent se conformer à la réglementation ATEX  
 A pedido, se pueden enviar nuestros productos de acuerdo con las normas ATEX.

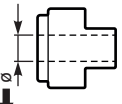
Type - Tipo - Typ Types - Tipo	Output flange Flangia uscita Ausgangsflansch Bride de sortie Brida en salida	Motor size - Grandezza motore Motor Größe Motor Grösse Grandeur moteur - Tamaño motor	Terminal box position Posizione morsettiera Klemmkastenlage Position boîte à bornes Posición caja de bornes	Mounting position Posizione montaggio Einbaulage Position de montage Posición de montaje	Coupling Giunto Kupplung Joint Juntura
<b>-N</b>	<b>N</b>	<b>-C</b>	<b>B</b>	<b>B3</b>	<b>C</b>
 <p><b>-N</b> Senza flangia Without flange</p>	 <p><b>N</b> Senza flangia Without flange H61C H62C H63C <b>4</b> → <b>∅250</b> H71C H72C H73C <b>4</b> → <b>∅250</b> <b>5</b> → <b>∅300</b> H81C H82C H83C <b>5</b> → <b>∅300</b> <b>6</b> → <b>∅350</b> <b>7</b> → <b>∅400</b></p>	<p>Flange Flangia </p> <p>Type R Tipo R </p> <p><b>B5</b> <b>-A</b>=56 (∅120) <b>-B</b>=63 (∅140) <b>-C</b>=71 (∅160) <b>-D</b>=80 (∅200) <b>-E</b>=90 (∅200) <b>-F</b>=100+112 (∅250) <b>-G</b>=132 (∅300) <b>-H</b>=160 (∅350) <b>-I</b>=180 (∅350)</p>	 <p><b>A</b></p>  <p><b>B</b> STANDARD</p>  <p><b>C</b></p>  <p><b>D</b></p>	 <p><b>B3</b> STANDARD</p>  <p><b>B6</b></p>  <p><b>B7</b></p>  <p><b>B8</b></p>	<p><b>0</b> Without coupling Senza giunto</p> 
 <p><b>-F</b> Whit output flange con flangia uscita</p>		<p>Without flange Senza flangia </p> <p><b>-M</b> → With coupling H63C H73C <b>-1</b> → <b>∅14</b> (71B5) <b>-2</b> → <b>∅19</b> (80B5) <b>-3</b> → <b>∅24</b> (90B5) <b>-4</b> → <b>∅28</b> (100B5)</p> <p>H62C H72C H83C <b>-2</b> → <b>∅19</b> (80B5) <b>-3</b> → <b>∅24</b> (90B5) <b>-4</b> → <b>∅28</b> (100B5)</p> <p><b>B14</b> <b>-O</b>=56 (∅80) <b>-P</b>=63 (∅90) <b>-Q</b>=71 (∅105) <b>-R</b>=80 (∅120) <b>-T</b>=90 (∅140) <b>-U</b>=100+112 (∅160) <b>-V</b>=132 (∅200)</p>		 <p><b>V5</b></p>  <p><b>V6</b></p>  <p><b>V8</b></p>	<p><b>-</b> Nothing indication: standard bore Nessuna indicazione: foro standard</p> <p>COUPLING</p>  <p><b>A</b> = 9mm <b>B</b> = 11mm <b>C</b> = 14mm <b>D</b> = 19mm <b>E</b> = 24mm <b>F</b> = 28mm</p>

POTENZA RICHIESTA / REQUIRED POWER / ERFORDERLICHE LEISTUNG / PUISSANCE NECESSAIRE / POTENCIA NECESARIA

Lifting / sollevamento / hubantriebe / levage / elevación

$$P \text{ [KW]} = \frac{M \text{ [Kg]} \cdot g \text{ [9.81]} \cdot v \text{ [m / s]}}{1000}$$

Rotation / rotazione / drehung / rotation / rotação

$$P \text{ [KW]} = \frac{M \text{ [Nm]} \cdot n \text{ [rpm]}}{9550}$$

Linear movement / traslazione / linearbewegung / translation / translación

$$P \text{ [KW]} = \frac{F \text{ [N]} \cdot v \text{ [m / s]}}{1000}$$

TORQUE / COPPIA / DREHMOMENT / COUPLE / PAR

$$M \text{ [Nm]} = \frac{9550 \cdot P \text{ [KW]}}{n \text{ [rpm]}}$$

$$M \text{ [lb in]} = \frac{63030 \cdot P \text{ [HP]}}{n \text{ [rpm]}}$$

RADIAL LOADS / CARICHI RADIALI / RADIALE - UND AXIALLASTEN / CHARGES RADIALES / CARGA RADIAL Y AXIAL

- Radial load generated by external transmissions keyed onto input and/or output shafts.
- Forza radiale generata da organi di trasmissione calettati sugli alberi di ingresso e/o uscita.
- Belastungen der Antriebs- bzw. Abtriebswellen durch von aussen eingebrachte Radiallasten.
- Charge radiale générée par la transmissions calés sur les entrées et / ou des arbres de sortie
- Cargas radiales, generada por transmisiones externas, aplicadas sobre los ejes de entrada y/o salida

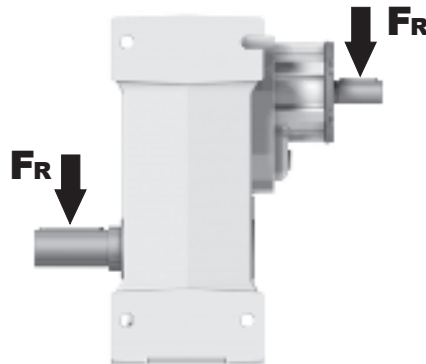

	$F_R \text{ [N]} = \frac{M \text{ [Nm]} \cdot 2000}{d \text{ [mm]}} \cdot f_k$	$F_R \text{ [N]} = \frac{M \text{ [lb in]} \cdot 8.9}{d \text{ [in]}} \cdot f_k$
<b>M</b>	Momento torcente / Output torque / Abtriebsdrehmoment / Couple / Par torsion	
<b>d</b>	Diametro primitivo / Diam. of driving element / Durchmesser der Abtriebseinheit / Diamètre primitif / Diámetro primitivo	
<b>f<sub>k</sub></b>	Coefficiente di trasformazione / Factor / Faktor / Coefficient de transmission / Coeficiente de transmisión <b>1.15</b> Ingranaggi / Gearwheels / Zahnrad / Engrenage / Engranaje <b>1.25</b> Catena / Chain sprockets / Antriebskette / Chaîne / Cadena <b>1.75</b> Cinghia Trapezoidale / Narrow v-belt pulley / Keilriemen / Courroie trap. / Correa trapezoidal <b>2.50</b> Cinghia piatta / Flat-belt pulley / Flachzahnriem. / Courroie crantée / Correa plana	

- If your application requires higher radial loads, contact our technical office. Higher load may be possible.
- Nel caso la vostra applicazione richieda carichi radiali superiori consultare il nostro ufficio tecnico, valori maggiori possono essere accettati.
- Wenn Ihre Anwendung höhere Radialbelastungen erfordert, so wenden Sie sich bitte an unser technischen Büro.
- Si votre application demande des charges radiales supérieures, s'adresser à notre bureau technique.
- En el caso en que una aplicación exija una carga radial superior a la especificada en el catálogo, consultar a nuestra oficinas técnica.

How to select a gearbox / Come selezionare un riduttore / Wie wählt man ein Getriebe  
Comment sélectionner un réducteur / Cómo seleccionar un reductor

**B** Output speed  
Velocità in uscita  
Abtriebsdrehzahl  
Vitesse de sortie  
Velocidad de salida

Nominal power  
Potenza nominale  
Max. mögliche Leistung  
Poissance nominale  
Potencia nominal

**A** Nominal torque  
Momento torcente nominale  
Nenn Drehmoment  
Couple nominal  
Par de torsión nominal

Flange code  
Codice flangia  
Flanschtype  
Code bride  
Código bridas

Input speed  
Velocità in entrata  
Eintriebsdrehzahl  
Vitesse en entrée  
Velocidad de entrada

Gear size  
Grandezza riduttore  
Getriebegröße  
Taille réducteur  
Tamaño reductor

Motor power  
Potenza motore  
Motorleistung  
Puisseance moteur  
Potencia motor

# H62C

**Cube gear 675Nm**

Rating - Cast Iron  
**PARALLEL SHAFT GEARBOXES**

QUICK SELECTION / Selezione veloce										input speed (n <sub>1</sub> ) = 1400 min <sup>-1</sup>							
Output Speed n <sub>2</sub> [min <sup>-1</sup> ]	Ratio i	Motor power P <sub>1M</sub> [kW]	Output torque M <sub>2M</sub> [Nm]	Service factor f.s.	Nominal power P <sub>1R</sub> [kW]	Nominal torque M <sub>2R</sub> [Nm]	Available B5 motor flanges					Available B14 motor flanges				Output Shaft 	Ratios code 
							-C	-D	-E	-F	-G	-R	-T	-U	-V		
213	<b>6.57</b>	7.5	312	1.2	8.8	380	B									3018	01
185	<b>7.56</b>	7.5	358	1.1	7.9	390	B									3016	02
159	<b>8.82</b>	7.5	419	1.0	7.1	410	B									3014	03
113	<b>12.39</b>	7.5	588	1.0	7.2	580	B									2018	04

**C** Ratio  
Rapporto  
Untersetzung  
Rapport de réduction  
Relación

Transmitted torque  
Momento torcente trasmesso  
Mögliche Drehmomente  
Couple de sortie  
Par transmitido

Service factor  
Fattore di servizio  
Betriebsfaktor  
Facteur de service  
Factor de servicio

Output shaft diam.  
Diam. albero uscita  
Durchmesser abtriebswelle  
Diametre arbre lent  
Diametro eje de salida

Notes  
Note  
Anmerkungen  
Note  
Notas

Type of load and starts per hour Tipo di carico e avviamenti per ora		Oper. hours per day Ore di funz. giorn.		
		3 h	10 h	24 h
Continuous or intermittent appl. with start / hour Applicazione cont. o interm. con n.ro operazioni/ora	Uniform / Uniforme	0.8	1	1.25
	Moderate / Moderato	1	1.25	1.5
	Heavy / Forte	1.25	1.5	1.75
Intermittent application with start / hour Applicazione intermittente con n.ro operazioni/ora	Uniform / Uniforme	1	1.25	1.5
	Moderate / Moderato	1.25	1.5	1.75
	Heavy / Forte	1.5	1.75	2.15

D Motor flange available Flange disponibili Erhältliche Motorflansche Brides disponibles Bridas disponibles	
B)	Mounting with reduction ring Montaggio con boccia di riduzione Reduzierhülsen Montage avec douille de réduction Montaje con casquillo de reducción
C)	Motor flangeholes position/terminal box position Posizione fori flangia/basetta motore Bohrungsposition am Motorflansch/-socket Position trous bride/barrette à bornes moteur Posición agujeros brida / base motor
B)	Available without reduction bushes Disponibile anche senza boccia Auch ohne Reduzierbuchse verfügbar Disponible aussi sans douille de réduction Disponible tambien sin casquillo

<b>A</b>	Select required torque (according to service factor)	Seleziona la coppia desiderata (comprensiva del fattore di servizio)	Max. Drehmoment in Bezug zum Betriebsfaktor	Sélectionner le couple souhaité (comprenant le facteur de service)	Seleccionar el par deseado (incluyendo el factor de servicio)
<b>B</b>	Select output speed	Seleziona la velocità in uscita	Ausgewählte Abtriebsdrehzahl	Sélectionner la vitesse de sortie	Seleccionar la velocidad de salida
<b>C</b>	On the same line of selected geared motor, you can find the gear ratio	Sulla riga corrispondente alla motorizzazione prescelta si può rilevare il rapporto di riduzione	Auf der gleichen Linie wie die ausgewählte Motorleistung steht auch die Getriebeuntersetzung	Sur la ligne correspondante à la motorisation pré-choisie on peut relever le rapport de réduction	En la línea correspondiente al motor preseleccionado es posible encontrar la relación de reducción
<b>D</b>	Select motor flange available (if requested)	Scegli la flangia disponibile (se richiesta)	Erhältliche Motorflansche (auf Anfrage)	Choisir la bride disponible (si elle est demandée)	Seleccionar la brida disponible (sobre pedido)





▪ **QUICK SELECTION** / Selezione veloce

input speed ( $n_1$ ) = 1400 min<sup>-1</sup>

Output Speed $n_2$ [min <sup>-1</sup> ]	Ratio $i$	Motor power $P_{1M}$ [kW]	Output torque $M_{2M}$ [Nm]	Service factor f.s.	Nominal power $P_{1R}$ [kW]	Nominal torque $M_{2R}$ [Nm]	Available B5 motor flanges		B14 motor flanges				Output Shaft		
							-G	132	-	-	-	-	-	-	-
507	<b>2.76</b>	9	166	1.6	<b>14.4</b>	<b>265</b>			<b>not available</b>				2980	<b>standard</b>	01
395	<b>3.54</b>	9	213	1.3	<b>11.6</b>	<b>275</b>							2485	<b>ø35</b>	02
277	<b>5.06</b>	9	304	1.0	<b>8.6</b>	<b>290</b>							1891		03
241	<b>5.81</b>	7.5	281	1.2	<b>8.5</b>	<b>330</b>							1693	ø40	04
206	<b>6.79</b>	7.5	329	1.2	<b>8.4</b>	<b>380</b>							1495	On request	05

The dynamic efficiency is **0.98** for all ratios

**A) Motor Flanges Available**  
Flange Motore Disponibili

**B) Supplied with Reduction Bushing**  
Fornito con Bussola di Riduzione

**B) Available on Request without reduction bushing**  
Disponibile a Richiesta senza Bussola di Riduzione

**C) Motor Flange Holes Position**  
Posizione Fori Flangia Motore

**EN** Unit **H61C** is supplied with synthetic oil for lifetime lubrication, no maintenance is necessary. See table 1 for lubrication and recommended quantity. In table 2 please see possible radial loads and axial loads on the gearbox.

**I** Il riduttore **H61C** viene fornito completo di olio sintetico per la lubrificazione permanente e non necessita di alcuna manutenzione. Vedi tab.1 per oli e quantità consigliati. In tab.2 sono presenti i carichi radiali e assiali applicabili al riduttore.

**D** Das Getriebe **H61C** ist mit synthetischem Öl gefüllt und ist lebensdauergeschmiert. In Tabelle 1 ist die Schmiermenge und das empfohlene Schmiermittel angegeben. In Tabelle 2 sind die zulässigen Radial - und Axialbelastungen des Getriebes aufgeführt.

**F** Le réducteur **H61C** est fourni complet avec de l'huile synthétique pour la lubrification permanente et ne nécessite aucun entretien. Voir tableau 1 concernant les huiles et les quantités conseillées. Les charges radiales et axiales applicables au réducteur sont précisées dans le tableau 2.

**E** El reductor tamaño **H61C** se suministra, lubricado de por vida con aceite sintético y no requieren mantenimiento alguna. Ver tabla 1, para cantidades y aceites recomendados. En la tabla 2, se encuentran las cargas radiales y axiales admitidas por el reductor.

Standard supplied	For these mounting position specify in the order or add oil							
	Per queste posizioni specificare in fase d'ordine o aggiungere olio							
B3	B6	B7	B8	V5	V6	V8	V8	V8
2.25 LT	3.20 LT	3.00 LT	2.25 LT	4.35 LT	2.35 LT	Ask	Ask	Ask
AGIP Telium VSF 320				SHELL Omala S4 WE 320				

For all details on lubrication and plugs check our website **tab. 1**  
Per maggiori dettagli su lubrificazione e tappi olio vedi il nostro sito web

### RADIAL AND AXIAL LOADS

**Output shaft**  
Albero di uscita

$F_R$  (N)  
 $F_A$  (N)

$F_{eq} = F_R \cdot \frac{149.5}{X+119.5}$

$F_{eq}$  (N)

$n_2$	FA	FR	$n_2$	FA	FR	$n_2$	FA	FR
300	600	3000	140	720	3600	70	940	4700
250	640	3200	120	740	3700	40	1220	6100
200	690	3460	85	860	4300	15	1300	6500

**On request reinforced bearings to increase loads.**  
A richiesta cuscinetti rinforzati per aumentare i carichi.

**tab. 2**

**P**H61C...

Basic gearbox  
Riduttore base

Gearbox weight  
peso riduttore **40.0 kg**

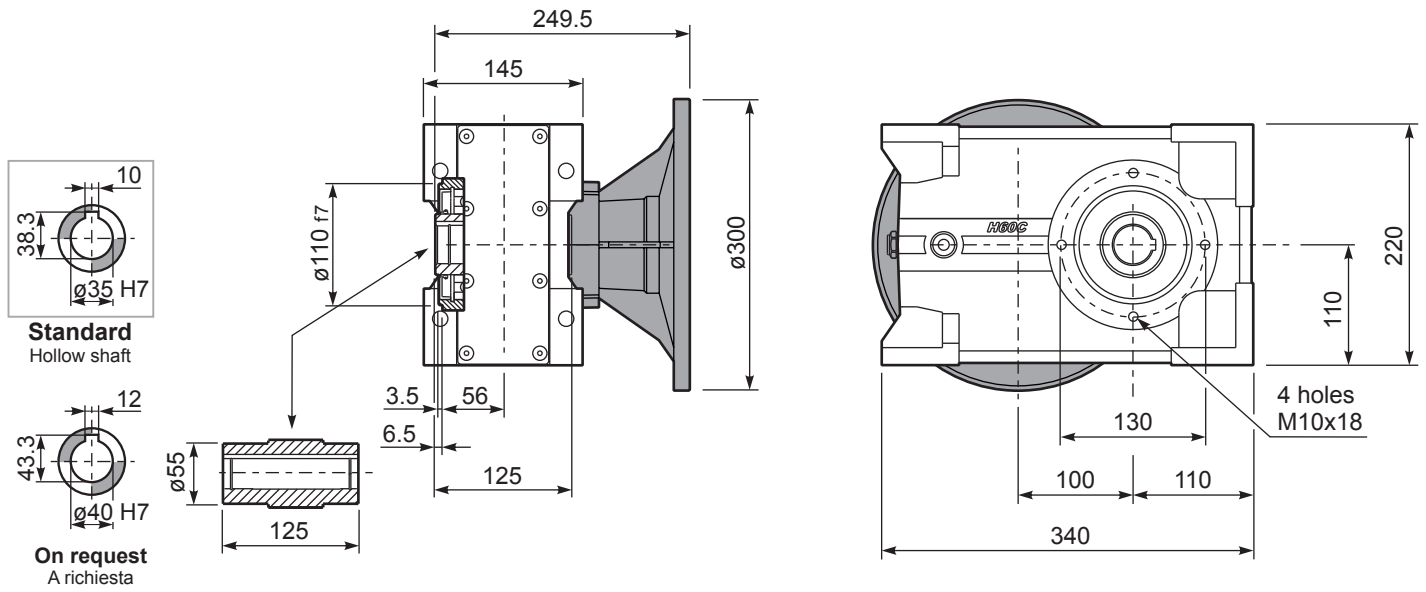

**PH61C...-N**

Feet  
Piedini

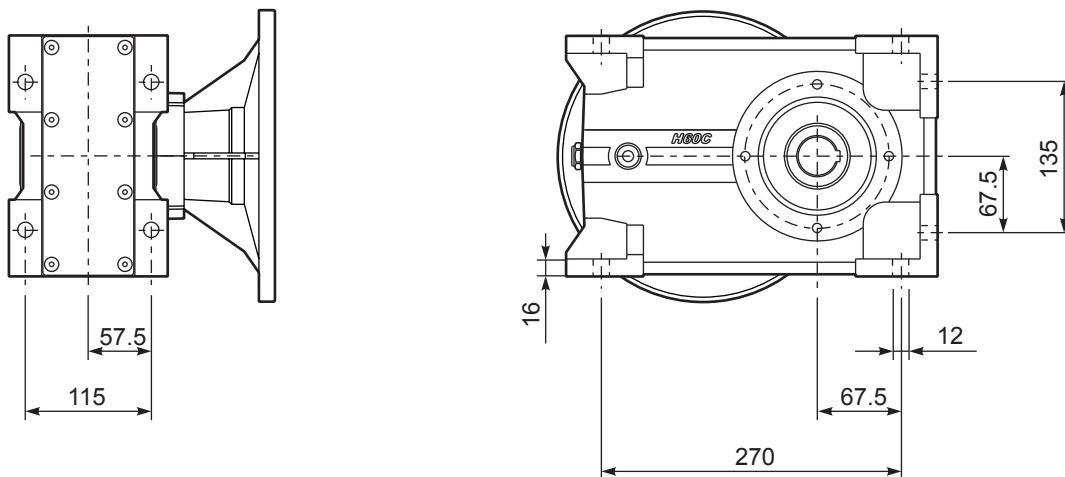

**PH61C...-F**

Output flange  
Flangia uscita

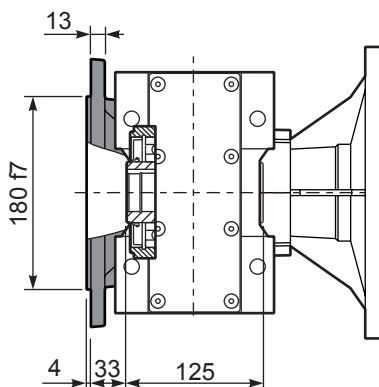

Kit. Cod KF60.9.011

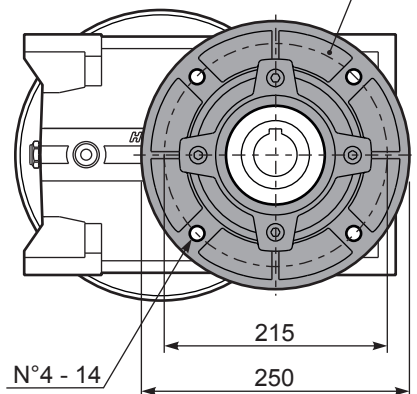

**PH61C A...**

Single output shaft  
Albero uscita semplice

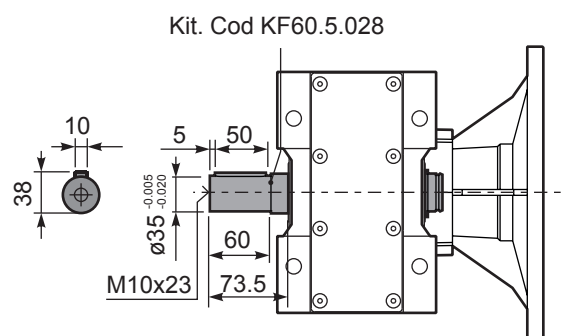

Kit. Cod KF60.5.028

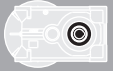

## QUICK SELECTION / Selezione veloce

input speed ( $n_1$ ) = 1400 min<sup>-1</sup>

Output Speed $n_2$ [min <sup>-1</sup> ]	Ratio $i$	Motor power $P_{1M}$ [kW]	Output torque $M_{2M}$ [Nm]	Service factor $f.s.$	Nominal power $P_{1R}$ [kW]	Nominal torque $M_{2R}$ [Nm]	Available B5 motor flanges					Available B14 motor flanges				Output Shaft 	Ratios code	
							-C	-D	-E	-F	-G	-R	-T	-U	-V			
							71	80	90	100 112	132	80	90	100 112	132			
213	<b>6.57</b>	7.5	312	1.2	8.8	380	B										3018	01
185	<b>7.56</b>	7.5	358	1.1	7.9	390	B										3016	02
159	<b>8.82</b>	7.5	419	1.0	7.1	410	B										3014	03
113	<b>12.39</b>	7.5	588	1.0	7.2	580	B										2018	04
98	<b>14.24</b>	5.5	499	1.2	6.4	600	B										2016	05
84	<b>16.75</b>	5.5	587	1.1	6.1	665	B										1618	06
73	<b>19.25</b>	5.5	675	1.0	5.4	675	B										1616	07
64	<b>21.78</b>	4	558	1.2	4.7	675	B										1318	08
56	<b>25.04</b>	4	642	1.1	4.1	675	B										1316	09
47.9	<b>29.23</b>	4	750	0.9	3.5	675	B										1314	10
45.7	<b>30.65</b>	3	592	1.1	3.4	675	B										1116	11
39.1	<b>35.78</b>	3	691	1.0	2.9	675	B										1114	12
36.3	<b>38.55</b>	2.2	548	1.1	2.3	580	B										818	13
31.6	<b>44.32</b>	2.2	630	1.1	2.3	665	B										816	14
27.1	<b>51.74</b>	2.2	735	0.9	2.0	675	B										814	15
22.9	<b>61.03</b>	1.1	437	1.1	1.2	480	B										616	16
19.6	<b>71.25</b>	1.1	510	1.1	1.2	560	B										614	17

The dynamic efficiency is **0.96** for all ratios

**Motor Flanges Available**  
Flange Motore Disponibili

**B) Supplied with Reduction Bushing**  
Fornito con Bussola di Riduzione

**B) Available on Request without reduction bushing**  
Disponibile a Richiesta senza Bussola di Riduzione

**C) Motor Flange Holes Position**  
Posizione Fori Flangia Motore

**EN** Unit **H62C** is supplied with synthetic oil for lifetime lubrication, no maintenance is necessary. See table 1 for lubrication and recommended quantity. In table 2 please see possible radial loads and axial loads on the gearbox.

**I** Il riduttore **H62C** viene fornito completo di olio sintetico per la lubrificazione permanente e non necessita di alcuna manutenzione. Vedi tab.1 per oli e quantità consigliati. In tab.2 sono presenti i carichi radiali e assiali applicabili al riduttore.

**D** Das Getriebe **H62C** ist mit synthetischem Öl gefüllt und ist lebensdauergeschmiert. In Tabelle 1 ist die Schmiermenge und das empfohlene Schmiermittel angegeben. In Tabelle 2 sind die zulässigen Radial - und Axialbelastungen des Getriebes aufgeführt.

**F** Le réducteur **H62C** est fourni complet avec de l'huile synthétique pour la lubrification permanente et ne nécessite aucun entretien. Voir tableau 1 concernant les huiles et les quantités conseillées. Les charges radiales et axiales applicables au réducteur sont précisées dans le tableau 2.

**E** El reductor tamaño **H62C** se suministra, lubricado de por vida con aceite sintético y no requieren mantenimiento alguna. Ver tabla 1, para cantidades y aceites recomendados. En la tabla 2, se encuentran las cargas radiales y axiales admitidas por el reductor.

Standard supplied	For these mounting position specify in the order or add oil					
	Per queste posizioni specificare in fase d'ordine o aggiungere olio					
B3	B6	B7	B8	V5	V6	V8
2.25 LT	3.20 LT	3.00 LT	2.25 LT	4.35 LT	2.35 LT	Ask
AGIP Telium VSF 320			SHELL Omala S4 WE 320			

For all details on lubrication and plugs check our website **tab. 1**  
Per maggiori dettagli su lubrificazione e tappi olio vedi il nostro sito web

### RADIAL AND AXIAL LOADS

**Output shaft**  
Albero di uscita

$F_{eq} = FR \cdot \frac{149.5}{X+119.5}$

$n_2$	FA	FR	$n_2$	FA	FR	$n_2$	FA	FR
300	600	3000	140	720	3600	70	940	4700
250	640	3200	120	740	3700	40	1220	6100
200	690	3460	85	860	4300	15	1300	6500

**On request reinforced bearings to increase loads.**  
A richiesta cuscinetti rinforzati per aumentare i carichi.

**Input shaft**  
Albero in entrata

$n_1$	FA	FR
1400	450	2250
900	500	2500
500	600	3000

tab. 2

**PH62C...** Basic gearbox  
Riduttore base

M. flanges	Kit code	øF	A
<b>71B5</b>	K023.4.041	160	227
<b>80/90B5</b>	K023.4.042	200	229
<b>100/112B5</b>	K023.4.043	250	238
<b>132B5</b>	KC50.4.043	300	256
<b>80B14</b>	K085.4.046	120	229
<b>90B14</b>	K085.4.045	140	229
<b>100/112B14</b>	K085.4.047	160	238
<b>132B14</b>	KC50.4.041	200	256

**Standard**  
Hollow shaft

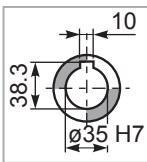

**On request**  
A richiesta

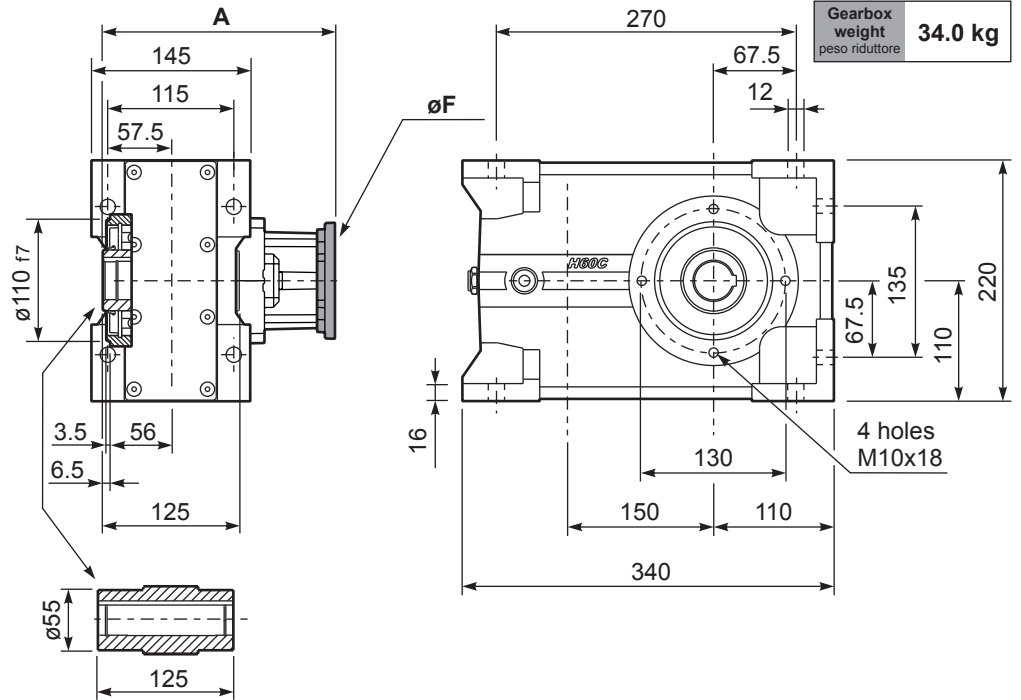
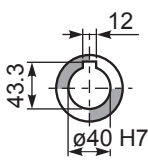

Gearbox weight  
peso riduttore **34.0 kg**

**PH62C...-F** Output flange  
Flangia uscita

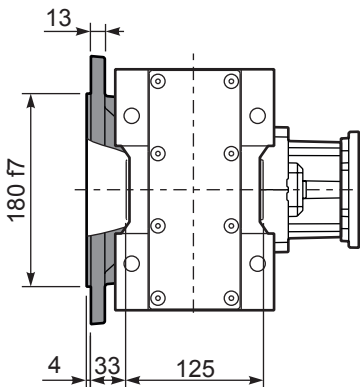

Kit. Cod KF60.9.011

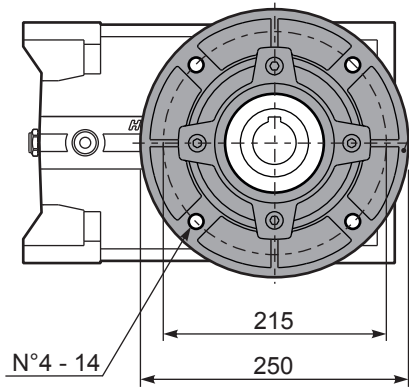

**PH62C D...** Shrink disk  
Calettatore

Kit. Cod KF60.0.210LM

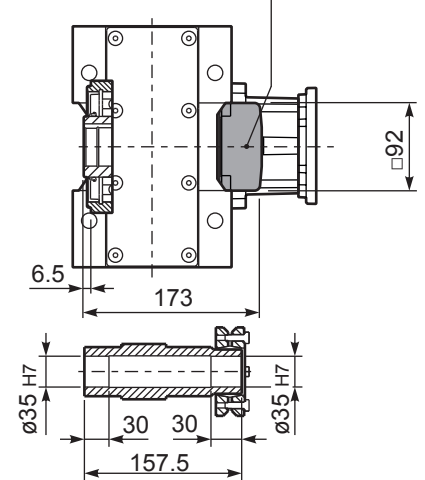

**RH62C...** Input Shaft  
Albero in entrata

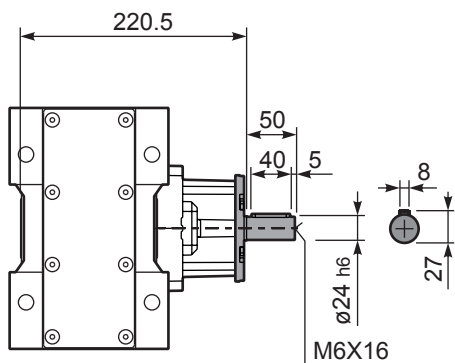

**PH62C A...** Single output shaft  
Albero uscita semplice

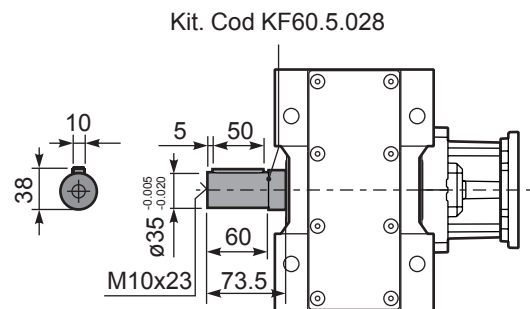



▪ **QUICK SELECTION** / Selezione veloce

input speed ( $n_1$ ) = 1400 min<sup>-1</sup>

Output Speed $n_2$ [min <sup>-1</sup> ]	Ratio $i$	Motor power $P_{1M}$ [kW]	Output torque $M_{2M}$ [Nm]	Service factor f.s.	Nominal power $P_{1R}$ [kW]	Nominal torque $M_{2R}$ [Nm]	Available B5 motor flanges				Available B14 motor flanges			Output Shaft 	Ratios code
							-B	-C	-D	-E	-Q	-R	-T		
							63	71	80	90	71	80	90		
22.6	<b>61.89</b>	1.5	594	1.1	1.7	675	B				C	C		191318	01
19.7	<b>71.16</b>	1.5	683	1.0	1.5	675	B				C	C		191316	02
17.0	<b>82.48</b>	1.5	792	0.9	1.3	675	B				C	C		171316	03
14.5	<b>96.29</b>	1.1	675	1.0	1.1	675	B				C	C		171314	04
13.9	<b>100.51</b>	1.1	705	1.0	1.0	675	B				C	C		131318	05
12.1	<b>115.56</b>	0.75	556	1.2	0.91	675	B				C	C		131316	06
11.1	<b>125.96</b>	0.75	606	1.1	0.82	665	B				C	C		190816	07
10.4	<b>134.91</b>	0.75	649	1.0	0.78	675	B				C	C		131314	08
9.5	<b>147.05</b>	0.75	707	1.0	0.72	675	B				C	C		190814	09
8.2	<b>170.44</b>	0.55	605	1.1	0.62	675	B				C	C		170814	10
7.6	<b>184.15</b>	0.55	653	1.0	0.57	675	B				C	C		101314	11
6.8	<b>205.87</b>	0.55	730	0.9	0.51	675	B				C	C		91316	12
5.8	<b>240.34</b>	0.37	570	1.2	0.44	675	B				C	C		91314	13
5.0	<b>279.22</b>	0.37	662	1.0	0.37	665	B				C	C		100816	14
4.3	<b>325.97</b>	0.37	773	0.9	0.32	675	B				C	C		100814	15
3.8	<b>364.41</b>	0.25	583	1.1	0.28	665	B				C	C		90816	16
3.3	<b>425.43</b>	0.25	681	1.0	0.25	675	B				C	C		90814	17
2.9	<b>481.19</b>	0.18	589	1.1	0.22	665	B				C	C		70816	18
2.5	<b>561.76</b>	0.18	687	1.0	0.19	675	B				C	C		70814	19

The dynamic efficiency is **0.94** for all ratios

Motor Flanges Available Flange Motore Disponibili  
 B) Supplied with Reduction Bushing Fornito con Bussola di Riduzione  
 B) Available on Request without reduction bushing Disponibile a Richiesta senza Bussola di Riduzione  
 C) Motor Flange Holes Position Posizione Fori Flangia Motore

**EN** Unit **H63C** is supplied with synthetic oil for lifetime lubrication, no maintenance is necessary. See table 1 for lubrication and recommended quantity. In table 2 please see possible radial loads and axial loads on the gearbox.

**I** Il riduttore **H63C** viene fornito completo di olio sintetico per la lubrificazione permanente e non necessita di alcuna manutenzione. Vedi tab.1 per oli e quantità consigliati. In tab.2 sono presenti i carichi radiali e assiali applicabili al riduttore.

**D** Das Getriebe **H63C** ist mit synthetischem Öl gefüllt und ist lebensdauergeschmiert. In Tabelle 1 ist die Schmiermenge und das empfohlene Schmiermittel angegeben. In Tabelle 2 sind die zulässigen Radial - und Axialbelastungen des Getriebes aufgeführt.

**F** Le réducteur **H63C** est fourni complet avec de l'huile synthétique pour la lubrification permanente et ne nécessite aucun entretien. Voir tableau 1 concernant les huiles et les quantités conseillées. Les charges radiales et axiales applicables au réducteur sont précisées dans le tableau 2.

**E** El reductor tamaño **H63C** se suministra, lubricado de por vida con aceite sintético y no requieren mantenimiento alguna. Ver tabla 1, para cantidades y aceites recomendados. En la tabla 2, se encuentran las cargas radiales y axiales admitidas por el reductor.

Standard supplied	For these mounting position specify in the order or add oil Per queste posizioni specificare in fase d'ordine o aggiungere olio							
B3	B6	B7	B8	V5	V6	V8	V8	V8
2.35 LT	3.85 LT	3.15 LT	2.35 LT	4.55 LT	2.50 LT	Ask	Ask	Ask
AGIP Telium VSF 320				SHELL Omala S4 WE 320				

For all details on lubrication and plugs check our website **tab. 1**  
Per maggiori dettagli su lubrificazione e tappi olio vedi il nostro sito web

### RADIAL AND AXIAL LOADS

**Output shaft**  
Albero di uscita

$F_{eq} = FR \cdot \frac{149.5}{X+119.5}$

$n_2$	FA	FR	$n_2$	FA	FR	$n_2$	FA	FR
300	600	3000	140	720	3600	70	940	4700
250	640	3200	120	740	3700	40	1220	6100
200	690	3460	85	860	4300	15	1300	6500

**On request reinforced bearings to increase loads.**  
A richiesta cuscinetti rinforzati per aumentare i carichi.

**Input shaft**  
Albero in entrata

$n_1$	FA	FR
1400	240	1200
900	280	1400
500	340	1700

tab. 2

**PH63C...** Basic gearbox  
Riduttore base

M. flanges	Kit code	øF	A
<b>63B5</b>	K063.4.041	140	239
<b>71B5</b>	K063.4.042	160	237
<b>80/90B5</b>	K063.4.043	200	239
<b>71B14</b>	K063.4.047	105	237
<b>80B14</b>	K063.4.046	120	239
<b>90B14</b>	K063.4.041	140	239

**Standard**  
Hollow shaft

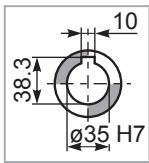

**On request**  
A richiesta

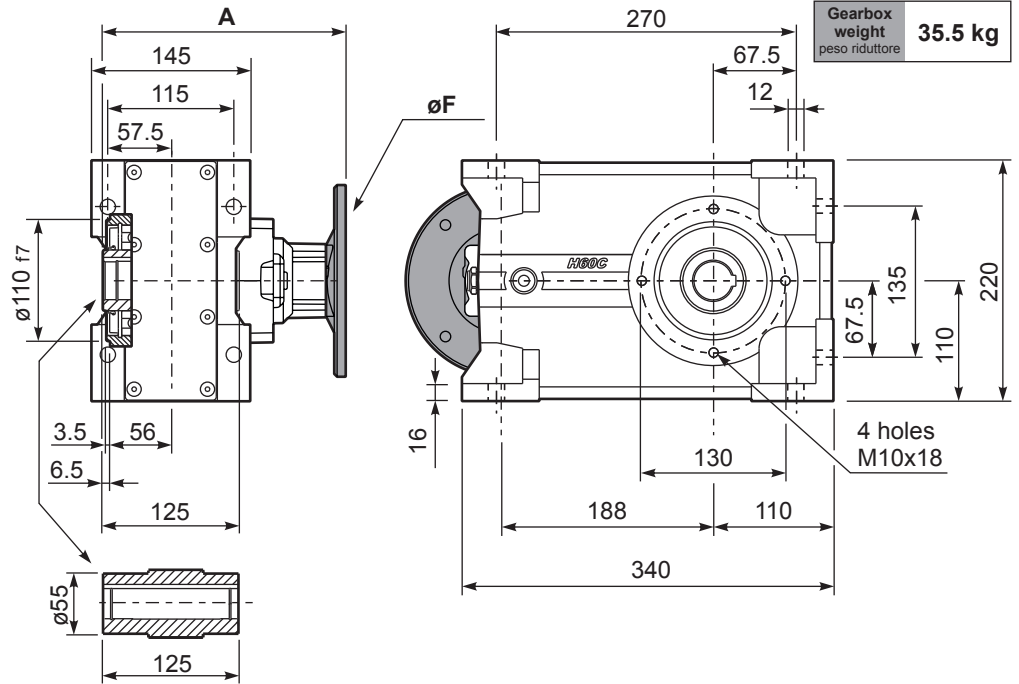
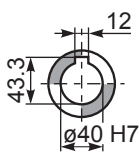

**PH63C...-F** Output flange  
Flangia uscita

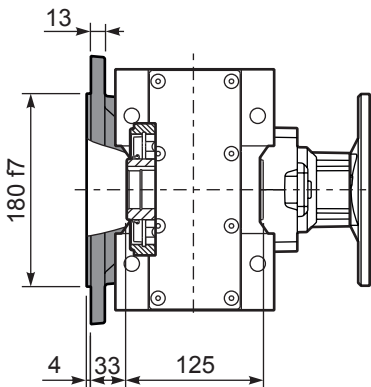

Kit. Cod KF60.9.011

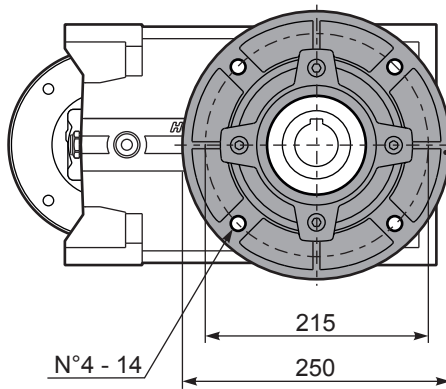

**PH63C D...** Shrink disk  
Calettatore

Kit. Cod KF60.0.210LM

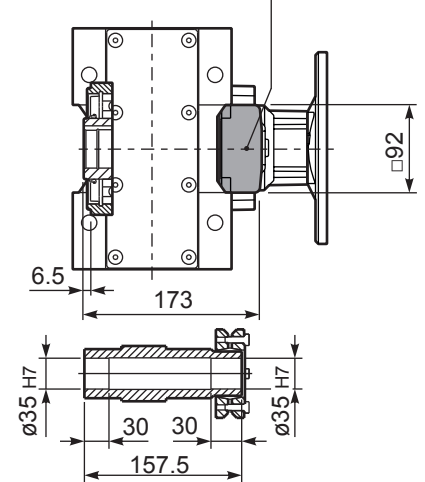

**RH63C...** Input Shaft  
Albero in entrata

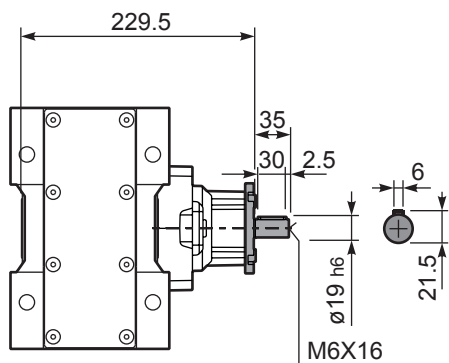

**PH63C A...** Single output shaft  
Albero uscita semplice

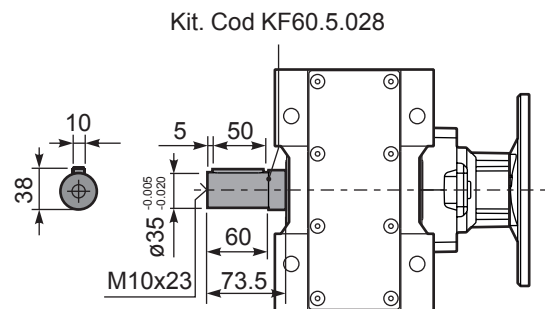



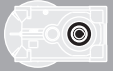

## QUICK SELECTION / Selezione veloce

input speed ( $n_1$ ) = 1400 min<sup>-1</sup>

Output Speed $n_2$ [min <sup>-1</sup> ]	Ratio $i$	Motor power $P_{1M}$ [kW]	Output torque $M_{2M}$ [Nm]	Service factor f.s.	Nominal power $P_{1R}$ [kW]	Nominal torque $M_{2R}$ [Nm]	Available B5 motor flanges				B14 motor flanges				Output Shaft		
							-G				-	-	-	-	-	-	-
227	<b>6.17</b>	9	371	1.2	<b>10.9</b>	<b>450</b>					<b>not available</b>				18111	<b>standard</b>	01
198	<b>7.06</b>	9	425	1.4	<b>12.7</b>	<b>600</b>									16113	<b>ø40</b>	02
170	<b>8.21</b>	9	494	1.4	<b>12.2</b>	<b>670</b>									14115	<b>ø45</b>	03
															On request		

The dynamic efficiency is **0.98** for all ratios

**A) Motor Flanges Available**  
Flange Motore Disponibili

**B) Supplied with Reduction Bushing**  
Fornito con Bussola di Riduzione

**B) Available on Request without reduction bushing**  
Disponibile a Richiesta senza Bussola di Riduzione

**C) Motor Flange Holes Position**  
Posizione Fori Flangia Motore

**EN** Unit **H71C** is supplied without lubricant and equipped with a breather, level and drain plugs. User can add mineral oil keeping existing plugs. Should the user wish to fill it with synthetic oil, it is recommended to replace the existing plugs with a closed plug.  
See table 1 for lubrication and recommended quantity.  
In table 2 please see possible radial loads and axial loads on the gearbox.

**I** Il riduttore tipo **H71C** è fornito privo di lubrificazione con tappi di sfiato, livello e scarico olio. L'utente può immettere olio minerale mantenendo i tappi esistenti. Se immetterà olio sintetico, dovrà sostituire i tappi esistenti con altri tipo chiuso.  
Tab.1 per oli e quantità consigliati.  
Tab.2 carichi radiali e assiali applicabili al riduttore.

**D** Das Getriebe der Baugröße **H71C** wird ohne Schmiermittel geliefert. Es ist jedoch mit Einfüllschraube, Überdruckventil und Ablassschraube ausgerüstet. Das benötigte mineralische Öl kann über die Einfüllschraube eingefüllt werden. Sollte synthetisches Öl bevorzugt werden, so ist sind das eingebaute Überdruckventil durch eine geschlossenen Schraube zu ersetzen.  
In Tabelle 1 ist die Schmiermenge und das empfohlene Schmiermittel angegeben  
In Tabelle 2 sind die zulässigen Radial - und Axialbelastungen des Getriebes aufgeführt.

**F** Le réducteur de type **H71C** est fourni sans lubrification et avec un bouchon de remplissage, de niveau et d'évacuation de l'huile. L'utilisateur peut y verser de l'huile minérale en conservant les bouchons existants. S'il y versera de l'huile synthétique, il devra substituer les bouchons existants avec d'autres bouchons de type fermé.  
Voir tableau 1 concernant les huiles et les quantités conseillées.  
Voir tableau 2 concernant les charges radiales et axiales applicables au réducteur

**E** El reductor tamaño **H71C** se suministra sin lubricante, provisto de tapones de respiración, nivel y descarga de aceite. El usuario puede utilizar aceite mineral, manteniendo los tapones existentes. Si prefiere utilizar aceite sintético deberá sustituir los tapones existentes por tapones ciegos. La prerreducción se suministra con tapones ciegos, lubricado de por vida con aceite sintético.  
Ver tabla 1, para cantidades y aceites recomendados.  
En la tabla 2, se encuentran las cargas radiales y axiales admitidas por el reductor.

B3	B6	B7	B8	V5	V6	V8
3.20 LT	4.65 LT	4.00 LT	3.20 LT	6.00 LT	3.10 LT	Ask
AGIP Blasia 460						

For all details on lubrication and plugs check our website **tab. 1**  
Per maggiori dettagli su lubrificazione e tappi olio vedi il nostro sito web

RADIAL AND AXIAL LOADS								
Output shaft			$F_{eq} = F_R \cdot \frac{174.5}{X+134.5}$					
Albero di uscita								
$n_2$	$F_A$	$F_R$	$n_2$	$F_A$	$F_R$	$n_2$	$F_A$	$F_R$
300	740	3700	140	860	4300	70	1020	5100
250	800	4000	120	900	4500	40	1300	6500
200	830	4150	85	970	4850	15	1700	8500
<b>On request reinforced bearings to increase loads.</b> A richiesta cuscinetti rinforzati per aumentare i carichi.								

**tab. 2**

**PH71C...** Basic gearbox  
Riduttore base

Gearbox weight  
peso riduttore **51.0 kg**

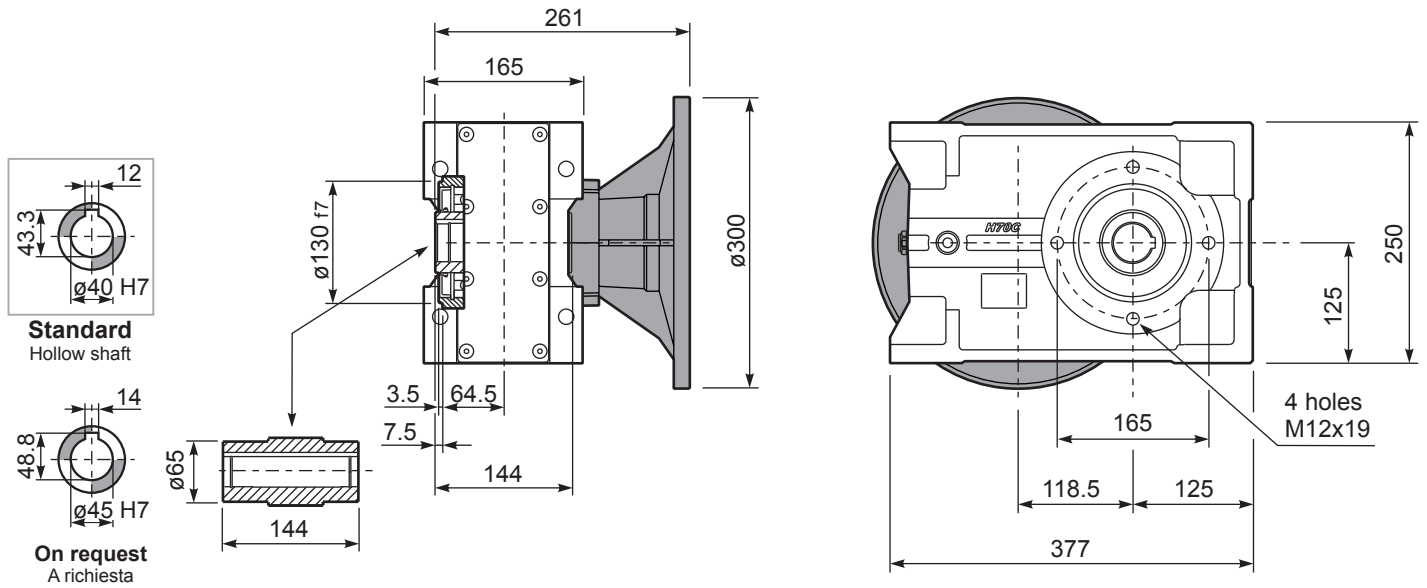

**PH71C...-F** Output flange  
Flangia uscita

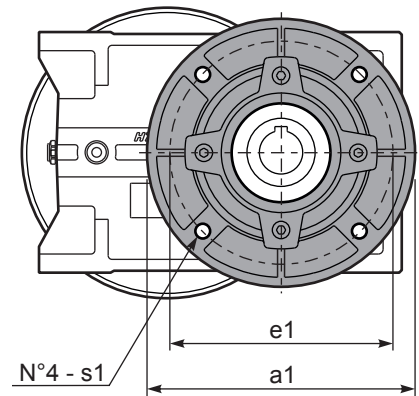
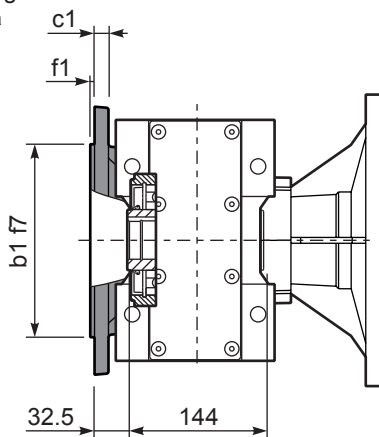

Available output flanges  
Flange di uscita

a1 ø	b1	c1	e1	f1	s1	Kit code
250	180	13	215	3	14	KF70.9.011
300	230	16	265	4	14	KF70.9.012

**PH71C...-N** Feet  
Piedini

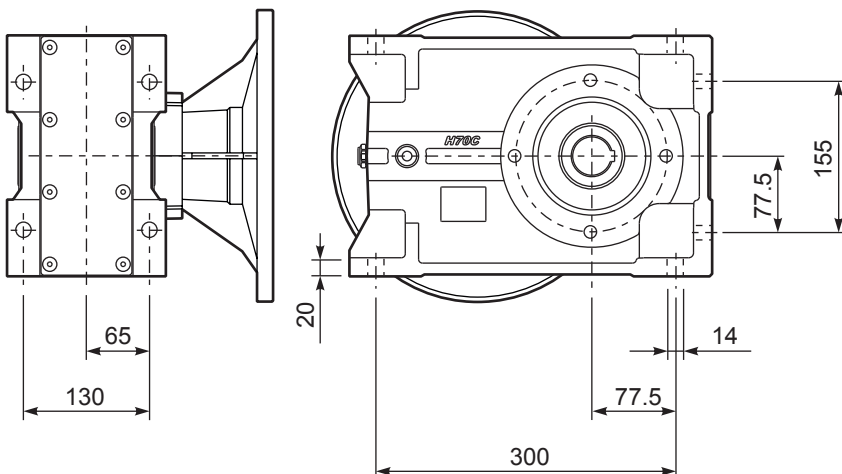

**PH71C A...** Single output shaft  
Albero uscita semplice

Kit. Cod KF70.5.028

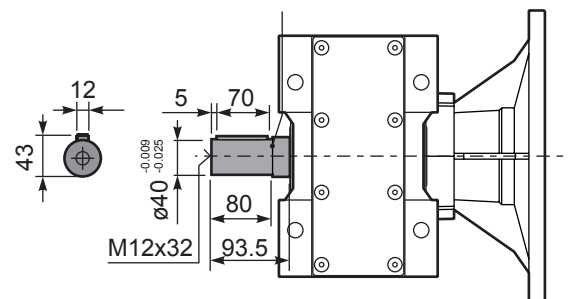

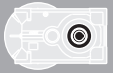

## QUICK SELECTION / Selezione veloce

input speed ( $n_1$ ) = 1400 min<sup>-1</sup>

Output Speed $n_2$ [min <sup>-1</sup> ]	Ratio $i$	Motor power $P_{1M}$ [kW]	Output torque $M_{2M}$ [Nm]	Service factor f.s.	Nominal power $P_{1R}$ [kW]	Nominal torque $M_{2R}$ [Nm]	Available B5 motor flanges					Available B14 motor flanges				Output Shaft 	Ratios code 	
							-C	-D	-E	-F	-G	-R	-T	-U	-V			
							71	80	90	100 112	132	80	90	100 112	132			
175	<b>8.02</b>	9	473	1.1	<b>9.9</b>	<b>520</b>	B										3018	01
152	<b>9.18</b>	9	541	1.1	<b>9.8</b>	<b>590</b>	B										3016	02
131	<b>10.68</b>	9	630	1.1	<b>9.7</b>	<b>680</b>	B										3014	03
93	<b>15.11</b>	7.5	717	1.1	<b>7.8</b>	<b>775</b>	B										2018	04
81	<b>17.30</b>	7.5	821	1.1	<b>7.8</b>	<b>885</b>	B										2016	05
70	<b>20.13</b>	7.5	955	0.9	<b>6.8</b>	<b>900</b>	B										2014	06
60	<b>23.39</b>	5.5	820	1.1	<b>5.9</b>	<b>900</b>	B										1616	07
51	<b>27.21</b>	5.5	954	0.9	<b>5.1</b>	<b>900</b>	B										1614	08
46.0	<b>30.42</b>	4	780	1.2	<b>4.5</b>	<b>900</b>	B										1316	09
39.6	<b>35.38</b>	4	907	1.0	<b>3.9</b>	<b>900</b>	B										1314	10
37.6	<b>37.24</b>	3	719	1.2	<b>3.7</b>	<b>895</b>	B										1116	11
32.3	<b>43.31</b>	3	836	1.1	<b>3.2</b>	<b>900</b>	B										1114	12
29.8	<b>47.02</b>	2.2	668	1.1	<b>2.3</b>	<b>705</b>	B										818	13
26.0	<b>53.85</b>	2.2	765	1.1	<b>2.3</b>	<b>810</b>	B										816	14
22.4	<b>62.63</b>	2.2	890	1.0	<b>2.2</b>	<b>900</b>	B										814	15
18.9	<b>74.16</b>	1.1	531	1.1	<b>1.2</b>	<b>585</b>	B										616	16
16.2	<b>86.25</b>	1.1	617	1.1	<b>1.2</b>	<b>680</b>	B										614	17

The dynamic efficiency is **0.96** for all ratios

**Motor Flanges Available**  
Flange Motore Disponibili

**B) Supplied with Reduction Bushing**  
Fornito con Bussola di Riduzione

**B) Available on Request without reduction bushing**  
Disponibile a Richiesta senza Bussola di Riduzione

**C) Motor Flange Holes Position**  
Posizione Fori Flangia Motore

**EN** Unit **H72C** is supplied without lubricant and equipped with a breather, level and drain plugs. User can add mineral oil keeping existing plugs. Should the user wish to fill it with synthetic oil, it is recommended to replace the existing plugs with a closed plug. See table 1 for lubrication and recommended quantity. In table 2 please see possible radial loads and axial loads on the gearbox.

**I** Il riduttore tipo **H72C** è fornito privo di lubrificazione con tappi di sfiato, livello e scarico olio. L'utente può immettere olio minerale mantenendo i tappi esistenti. Se immetterà olio sintetico, dovrà sostituire i tappi esistenti con altri tipo chiuso. Tab.1 per oli e quantità consigliati. Tab.2 carichi radiali e assiali applicabili al riduttore.

**D** Das Getriebe der Baugröße **H72C** wird ohne Schmiermittel geliefert. Es ist jedoch mit Einfüllschraube, Überdruckventil und Ablassschraube ausgerüstet. Das benötigte mineralische Öl kann über die Einfüllschraube eingefüllt werden. Sollte synthetisches Öl bevorzugt werden, so ist sind das eingebaute Überdruckventil durch eine geschlossenen Schraube zu ersetzen. In Tabelle 1 ist die Schmiermenge und das empfohlene Schmiermittel angegeben. In Tabelle 2 sind die zulässigen Radial - und Axialbelastungen des Getriebes aufgeführt.

**F** Le réducteur de type **H72C** est fourni sans lubrification et avec un bouchon de remplissage, de niveau et d'évacuation de l'huile. L'utilisateur peut y verser de l'huile minérale en conservant les bouchons existants. S'il y versera de l'huile synthétique, il devra substituer les bouchons existants avec d'autres bouchons de type fermé. Voir tableau 1 concernant les huiles et les quantités conseillées. Voir tableau 2 concernant les charges radiales et axiales applicables au réducteur.

**E** El reductor tamaño **H72C** se suministra sin lubricante, provisto de tapones de respiración, nivel y descarga de aceite. El usuario puede utilizar aceite mineral, manteniendo los tapones existentes. Si prefiere utilizar aceite sintético deberá sustituir los tapones existentes por tapones ciegos. La prerreducción se suministra con tapones ciegos, lubricado de por vida con aceite sintético. Ver tabla 1, para cantidades y aceites recomendados. En la tabla 2, se encuentran las cargas radiales y axiales admitidas por el reductor.

B3	B6	B7	B8	V5	V6	V8
3.20 LT	4.65 LT	4.00 LT	3.20 LT	6.20 LT	3.10 LT	Ask

AGIP Blasias 460

For all details on lubrication and plugs check our website **tab. 1**  
Per maggiori dettagli su lubrificazione e tappi olio vedi il nostro sito web

### RADIAL AND AXIAL LOADS

**Output shaft**  
Albero di uscita

$F_{eq} = F_R \cdot \frac{174.5}{X+134.5}$

$n_2$	FA	FR	$n_2$	FA	FR	$n_2$	FA	FR
300	740	3700	140	860	4300	70	1020	5100
250	800	4000	120	900	4500	40	1300	6500
200	830	4150	85	970	4850	15	1700	8500

**On request reinforced bearings to increase loads.**  
A richiesta cuscinetti rinforzati per aumentare i carichi.

**Input shaft**  
Albero in entrata

$n_1$	FA	FR
1400	450	2250
900	500	2500
500	600	3000

tab. 2

**PH72C...**

Basic gearbox  
Riduttore base

M. flanges	Kit code	øF	A
71B5	K023.4.041	160	238.5
80/90B5	K023.4.042	200	240.5
100/112B5	K023.4.043	250	249.5
132B5	KC50.4.043	300	267.5
80B14	K085.4.046	120	240.5
90B14	K085.4.045	140	240.5
100/112B14	K085.4.047	160	249.5
132B14	KC50.4.041	200	267.5

**Standard**  
Hollow shaft

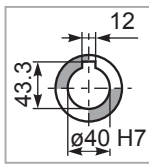

**On request**  
A richiesta

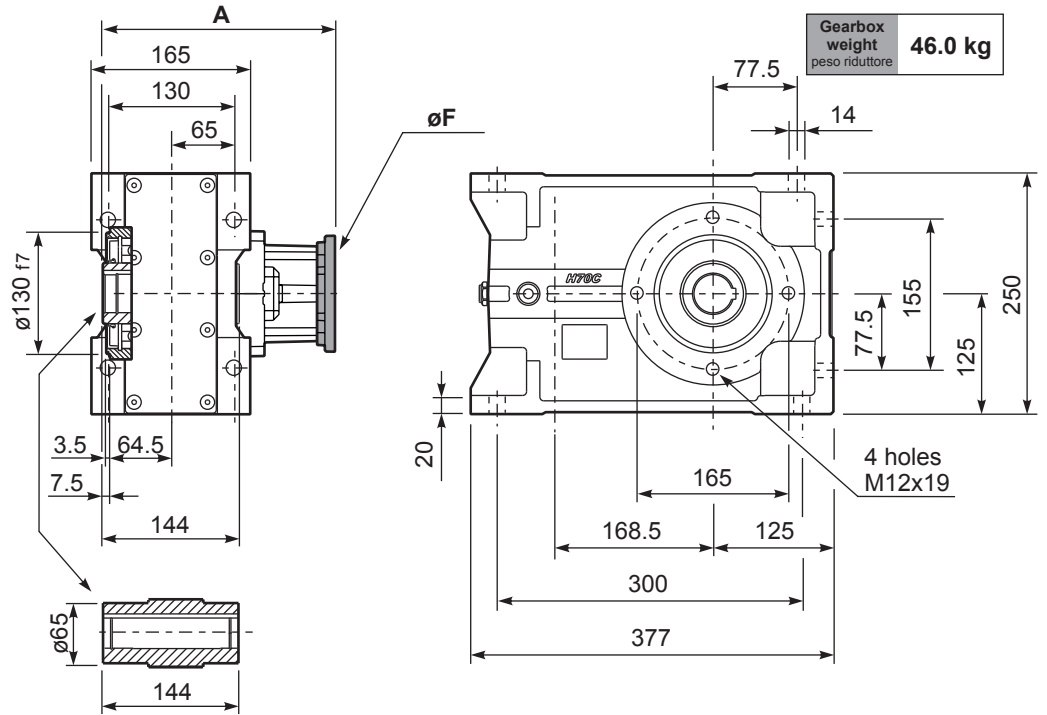
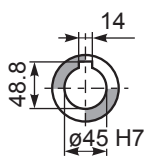

**PH72C...-F**

Output flange  
Flangia uscita

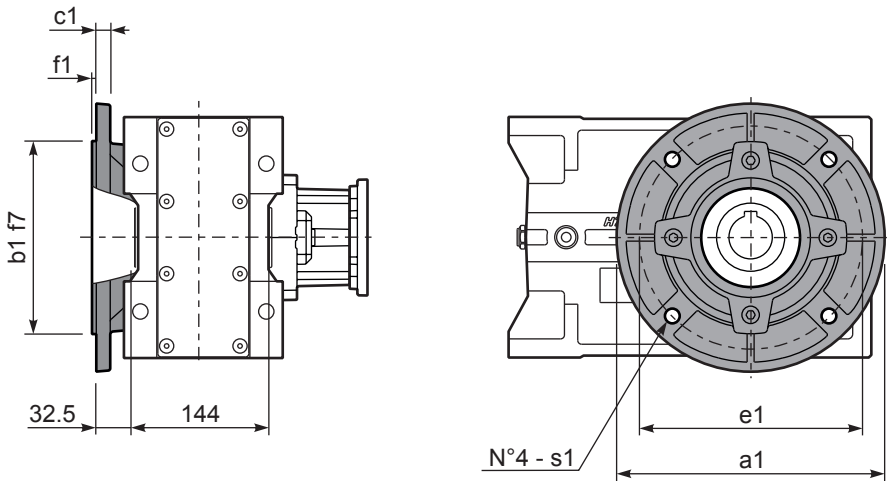

**Available output flanges**

Flange di uscita

a1 ø	b1	c1	e1	f1	s1	Kit code
250	180	13	215	3	14	KF70.9.011
300	230	16	265	4	14	KF70.9.012

**PH72C D...**

Shrink disk  
Calettatore

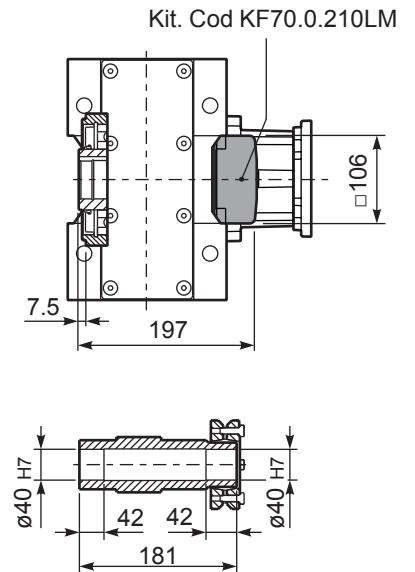

**RH72C...**

Input Shaft  
Albero in entrata

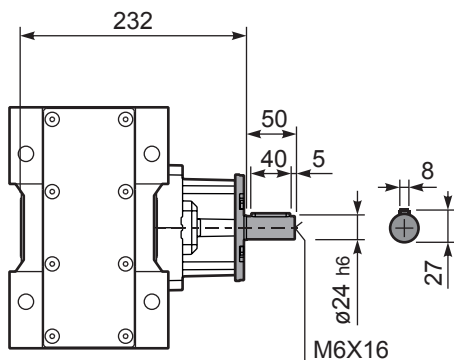

**PH72C A...**

Single output shaft  
Albero uscita semplice

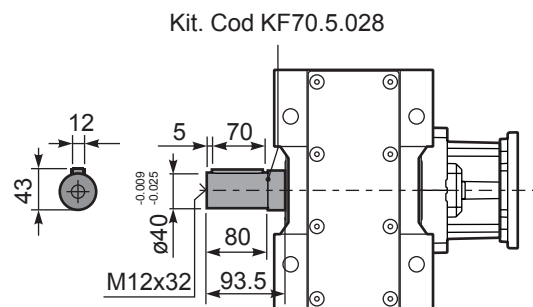



**QUICK SELECTION / Selezione veloce**

input speed ( $n_1$ ) = 1400 min<sup>-1</sup>

Output Speed $n_2$ [min <sup>-1</sup> ]	Ratio $i$	Motor power $P_{1M}$ [kW]	Output torque $M_{2M}$ [Nm]	Service factor $f.s.$	Nominal power $P_{1R}$ [kW]	Nominal torque $M_{2R}$ [Nm]	Available B5 motor flanges				Available B14 motor flanges			Output Shaft  $\varnothing$	Ratios code 
							-B	-C	-D	-E	-Q	-R	-T		
							63	71	80	90	71	80	90		
18.5	<b>75.50</b>	1.5	725	1.1	1.7	825	B				C	C		191318	01
16.2	<b>86.47</b>	1.5	830	1.1	1.6	900	B				C	C		191316	02
14.0	<b>100.22</b>	1.5	962	0.9	1.4	900	B				C	C		171316	03
12.0	<b>116.56</b>	1.1	817	1.1	1.2	900	B				C	C		171314	04
10.2	<b>136.82</b>	1.1	959	0.9	1.0	900	B				C	C		151314	05
9.1	<b>153.05</b>	0.75	736	1.1	0.83	810	B				C	C		190816	06
8.6	<b>163.31</b>	0.75	785	1.1	0.86	900	B				C	C		131314	07
7.9	<b>178.01</b>	0.75	856	1.1	0.79	900	B				C	C		190814	08
7.3	<b>191.67</b>	0.75	922	1.0	0.73	900	B				C	C		101316	09
6.8	<b>206.32</b>	0.75	992	0.9	0.68	900	B				C	C		170814	10
6.3	<b>222.92</b>	0.55	791	1.1	0.63	900	B				C	C		101314	11
5.8	<b>242.18</b>	0.55	859	1.0	0.58	900	B				C	C		150814	12
5.6	<b>250.15</b>	0.55	888	1.0	0.56	900	B				C	C		91316	13
4.8	<b>289.08</b>	0.55	1026	0.9	0.49	900	B				C	C		130814	14
4.2	<b>330.31</b>	0.37	783	1.1	0.42	890	B				C	C		71316	15
3.5	<b>394.59</b>	0.37	936	1.0	0.36	900	B				C	C		100814	16
2.7	<b>514.99</b>	0.25	824	1.1	0.27	900	B				C	C		90814	17
2.1	<b>680.03</b>	0.18	832	1.1	0.21	900	B				C	C		70814	18

The dynamic efficiency is **0.94** for all ratios

**Motor Flanges Available**  
Flange Motore Disponibili

**B) Supplied with Reduction Bushing**  
Fornito con Bussola di Riduzione

**B) Available on Request without reduction bushing**  
Disponibile a Richiesta senza Bussola di Riduzione

**C) Motor Flange Holes Position**  
Posizione Fori Flangia Motore

**EN** Unit **H73C** is supplied without lubricant and equipped with a breather, level and drain plugs. User can add mineral oil keeping existing plugs. Should the user wish to fill it with synthetic oil, it is recommended to replace the existing plugs with a closed plug. See table 1 for lubrication and recommended quantity. In table 2 please see possible radial loads and axial loads on the gearbox.

**I** Il riduttore tipo **H73C** è fornito privo di lubrificazione con tappi di sfiato, livello e scarico olio. L'utente può immettere olio minerale mantenendo i tappi esistenti. Se immetterà olio sintetico, dovrà sostituire i tappi esistenti con altri tipo chiuso. Tab.1 per oli e quantità consigliati. Tab.2 carichi radiali e assiali applicabili al riduttore.

**D** Das Getriebe der Baugröße **H73C** wird ohne Schmiermittel geliefert. Es ist jedoch mit Einfüllschraube, Überdruckventil und Ablassschraube ausgerüstet. Das benötigte mineralische Öl kann über die Einfüllschraube eingefüllt werden. Sollte synthetisches Öl bevorzugt werden, so ist sind das eingebaute Überdruckventil durch eine geschlossenen Schraube zu ersetzen. In Tabelle 1 ist die Schmiermenge und das empfohlene Schmiermittel angegeben. In Tabelle 2 sind die zulässigen Radial - und Axialbelastungen des Getriebes aufgeführt.

**F** Le réducteur de type **H73C** est fourni sans lubrification et avec un bouchon de remplissage, de niveau et d'évacuation de l'huile. L'utilisateur peut y verser de l'huile minérale en conservant les bouchons existants. S'il y versera de l'huile synthétique, il devra substituer les bouchons existants avec d'autres bouchons de type fermé. Voir tableau 1 concernant les huiles et les quantités conseillées. Voir tableau 2 concernant les charges radiales et axiales applicables au réducteur.

**E** El reductor tamaño **H73C** se suministra sin lubricante, provisto de tapones de respiración, nivel y descarga de aceite. El usuario puede utilizar aceite mineral, manteniendo los tapones existentes. Si prefiere utilizar aceite sintético deberá sustituir los tapones existentes por tapones ciegos. La prerreducción se suministra con tapones ciegos, lubricado de por vida con aceite sintético. Ver tabla 1, para cantidades y aceites recomendados. En la tabla 2, se encuentran las cargas radiales y axiales admitidas por el reductor.

B3	B6	B7	B8	V5	V6	V8
3.30 LT	5.70 LT	4.15 LT	3.30 LT	6.40 LT	3.25 LT	Ask

AGIP Blasias 460

For all details on lubrication and plugs check our website **tab. 1**  
Per maggiori dettagli su lubrificazione e tappi olio vedi il nostro sito web

### RADIAL AND AXIAL LOADS

**Output shaft**  
Albero di uscita

$F_{eq} = F_R \cdot \frac{174.5}{X+134.5}$

$n_2$	FA	FR	$n_2$	FA	FR	$n_2$	FA	FR
300	740	3700	140	860	4300	70	1020	5100
250	800	4000	120	900	4500	40	1300	6500
200	830	4150	85	970	4850	15	1700	8500

**On request reinforced bearings to increase loads.**  
A richiesta cuscinetti rinforzati per aumentare i carichi.

**Input shaft**  
Albero in entrata

$n_1$	FA	FR
1400	400	2000
900	440	2200
500	440	2200

**tab. 2**



**PH73C...**

Basic gearbox  
Riduttore base

Gearbox weight  
peso riduttore **43.5 kg**

M. flanges	Kit code	øF	A
<b>63B5</b>	K063.4.041	140	250.5
<b>71B5</b>	K063.4.042	160	248.5
<b>80/90B5</b>	K063.4.043	200	250.5
<b>71B14</b>	K063.4.047	105	248.5
<b>80B14</b>	K063.4.046	120	250.5
<b>90B14</b>	K063.4.041	140	250.5

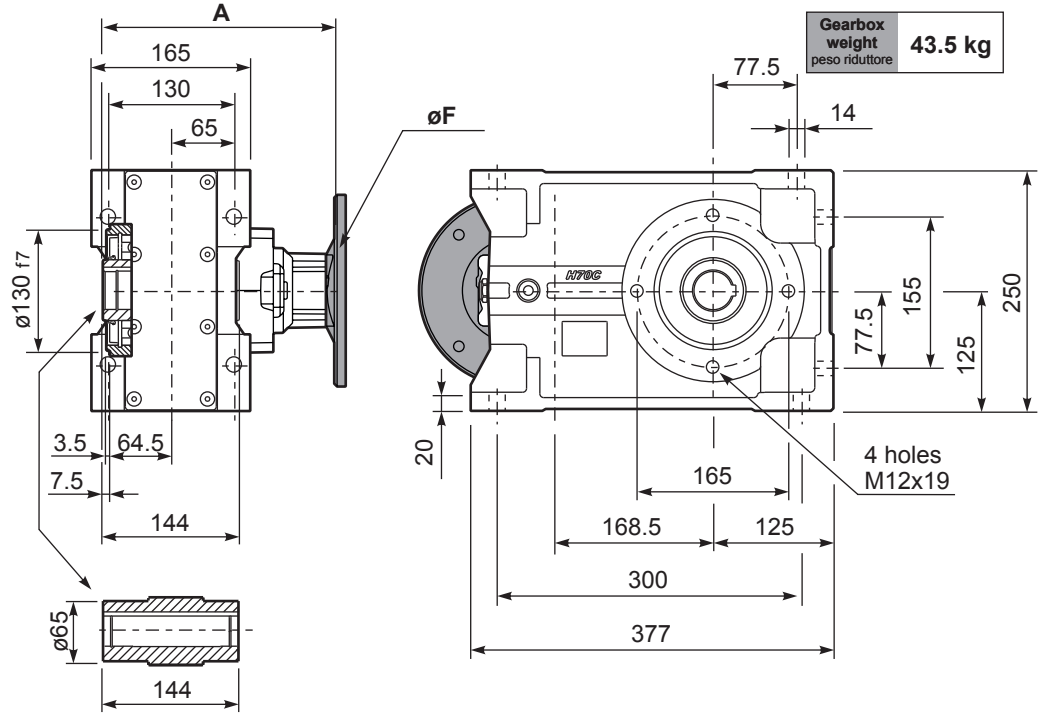

**Standard**  
Hollow shaft

**On request**  
A richiesta

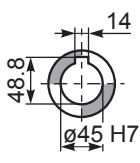
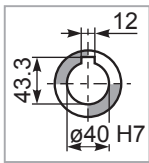

**PH73C...-F**

Output flange  
Flangia uscita

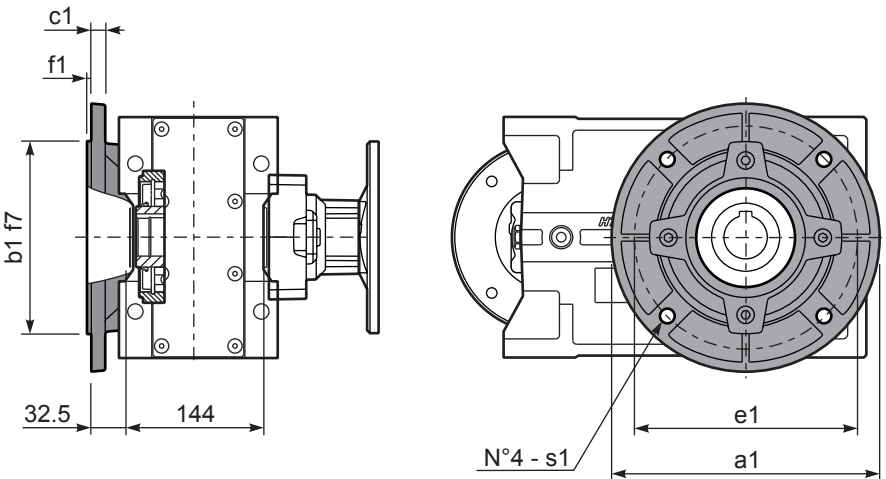

Available output flanges  
Flange di uscita

a1 ø	b1	c1	e1	f1	s1	Kit code
250	180	13	215	3	14	KF70.9.011
300	230	16	265	4	14	KF70.9.012

**PH73C D...**

Shrink disk  
Calettatore

Kit. Cod KF70.0.210LM

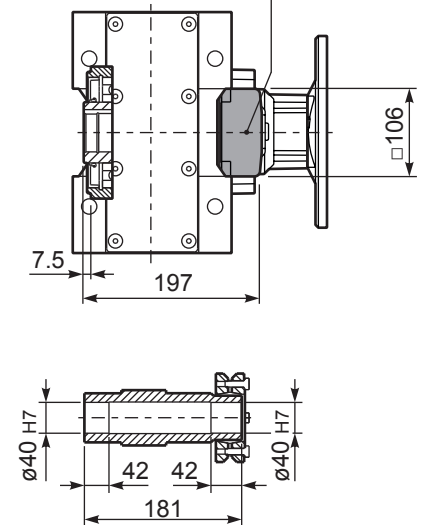

**RH73C...**

Input Shaft  
Albero in entrata

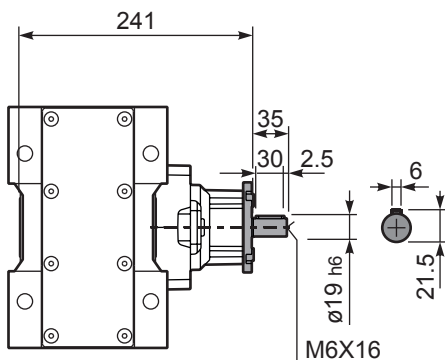

**PH73C A...**

Single output shaft  
Albero uscita semplice

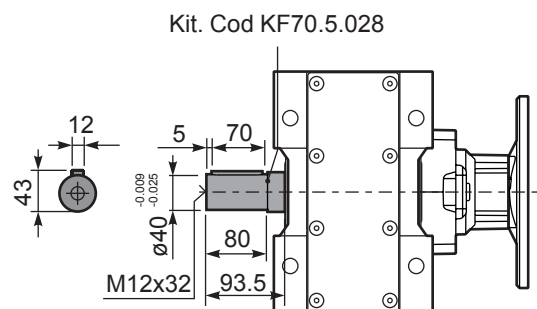





## QUICK SELECTION / Selezione veloce

input speed ( $n_1$ ) = 1400 min<sup>-1</sup>

Output Speed $n_2$ [min <sup>-1</sup> ]	Ratio $i$	Motor power $P_{1M}$ [kW]	Output torque $M_{2M}$ [Nm]	Service factor f.s.	Nominal power $P_{1R}$ [kW]	Nominal torque $M_{2R}$ [Nm]	Available B5 motor flanges		B14 motor flanges				Output Shaft 	Ratios code	
							-H	-I	-	-	-	-			-
528	<b>2.65</b>	22	374	1.7	<b>36.7</b>	<b>650</b>			<b>not available</b>				2361	<b>standard</b>	01
409	<b>3.42</b>	22	483	1.6	<b>32.8</b>	<b>750</b>							1965	<b>ø50</b>	02
304	<b>4.60</b>	22	649	1.5	<b>30.9</b>	<b>950</b>							1569		03
256	<b>5.46</b>	22	771	1.3	<b>27.4</b>	<b>1000</b>							1371	ø55	04
211	<b>6.64</b>	22	937	1.3	<b>26.5</b>	<b>1175</b>							1173	On request	05

The dynamic efficiency is **0.98** for all ratios

**A) Motor Flanges Available**  
Flange Motore Disponibili

**B) Supplied with Reduction Bushing**  
Fornito con Bussola di Riduzione

**B) Available on Request without reduction bushing**  
Disponibile a Richiesta senza Bussola di Riduzione

**C) Motor Flange Holes Position**  
Posizione Fori Flangia Motore

**EN** Unit **H81C** is supplied without lubricant and equipped with a breather, level and drain plugs. User can add mineral oil keeping existing plugs. Should the user wish to fill it with synthetic oil, it is recommended to replace the existing plugs with a closed plug. See table 1 for lubrication and recommended quantity. In table 2 please see possible radial loads and axial loads on the gearbox.

**I** Il riduttore tipo **H81C** è fornito privo di lubrificazione con tappi di sfiato, livello e scarico olio. L'utente può immettere olio minerale mantenendo i tappi esistenti. Se immetterà olio sintetico, dovrà sostituire i tappi esistenti con altri tipo chiuso. Tab.1 per oli e quantità consigliati. Tab.2 carichi radiali e assiali applicabili al riduttore.

**D** Das Getriebe der Baugröße **H81C** wird ohne Schmiermittel geliefert. Es ist jedoch mit Einfüllschraube, Überdruckventil und Ablassschraube ausgerüstet. Das benötigte mineralische Öl kann über die Einfüllschraube eingefüllt werden. Sollte synthetisches Öl bevorzugt werden, so ist sind das eingebaute Überdruckventil durch eine geschlossenen Schraube zu ersetzen. In Tabelle 1 ist die Schmiermenge und das empfohlene Schmiermittel angegeben. In Tabelle 2 sind die zulässigen Radial - und Axialbelastungen des Getriebes aufgeführt.

**F** Le réducteur de type **H81C** est fourni sans lubrification et avec un bouchon de remplissage, de niveau et d'évacuation de l'huile. L'utilisateur peut y verser de l'huile minérale en conservant les bouchons existants. S'il y versera de l'huile synthétique, il devra substituer les bouchons existants avec d'autres bouchons de type fermé. Voir tableau 1 concernant les huiles et les quantités conseillées. Voir tableau 2 concernant les charges radiales et axiales applicables au réducteur

**E** El reductor tamaño **H81C** se suministra sin lubricante, provisto de tapones de respiración, nivel y descarga de aceite. El usuario puede utilizar aceite mineral, manteniendo los tapones existentes. Si prefiere utilizar aceite sintético deberá sustituir los tapones existentes por tapones ciegos. La prerreducción se suministra con tapones ciegos, lubricado de por vida con aceite sintético. Ver tabla 1, para cantidades y aceites recomendados. En la tabla 2, se encuentran las cargas radiales y axiales admitidas por el reductor.

B3	B6	B7	B8	V5	V6	V8
5.70 LT	7.00 LT	7.90 LT	5.70 LT	10.20 LT	5.60 LT	Ask
AGIP Blasias 460						

For all details on lubrication and plugs check our website **tab. 1**  
Per maggiori dettagli su lubrificazione e tappi olio vedi il nostro sito web

RADIAL AND AXIAL LOADS								
Output shaft Albero di uscita			$F_{eq} = F_R \cdot \frac{227.5}{X+177.5}$					
$n_2$	FA	FR	$n_2$	FA	FR	$n_2$	FA	FR
300	920	4600	140	1120	5600	70	1400	7000
250	1000	5000	120	1140	5700	40	1800	9000
200	1060	5300	85	1300	6500	15	2400	12000
<b>On request reinforced bearings to increase loads.</b> A richiesta cuscinetti rinforzati per aumentare i carichi.								

**tab. 2**

**PH81C...**

Basic gearbox  
Riduttore base

Gearbox weight  
peso riduttore **89.0 kg**

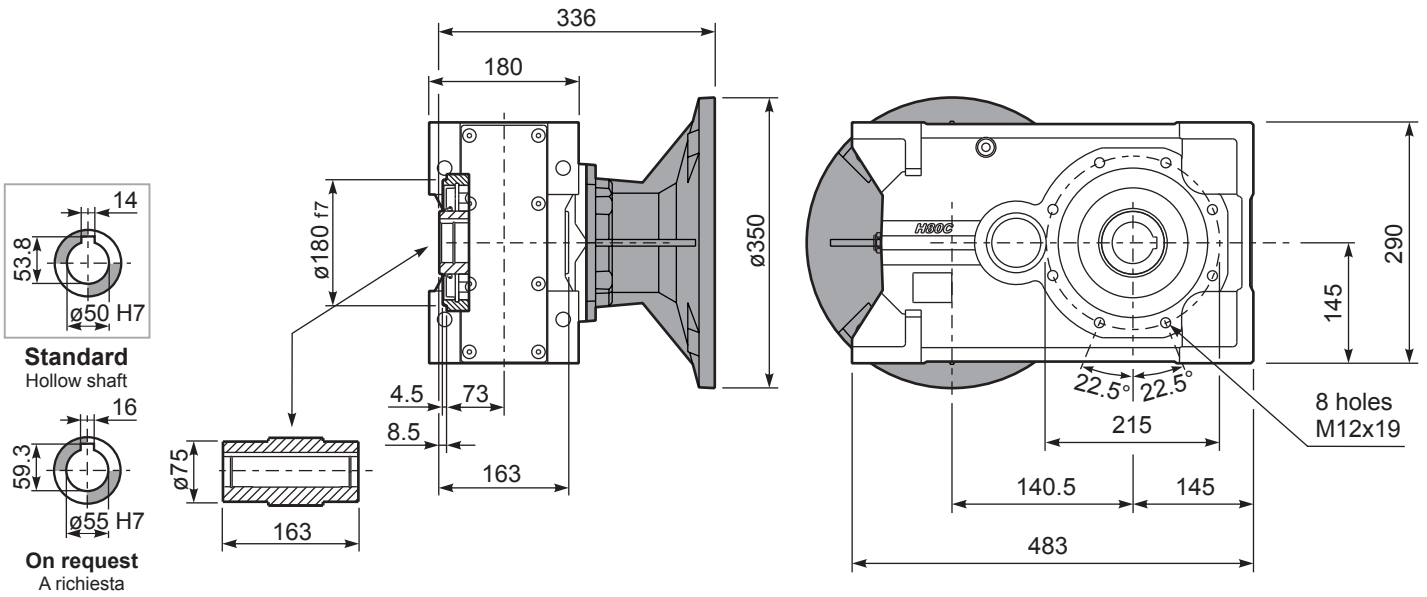

**PH81C...-F**

Output flange  
Flangia uscita

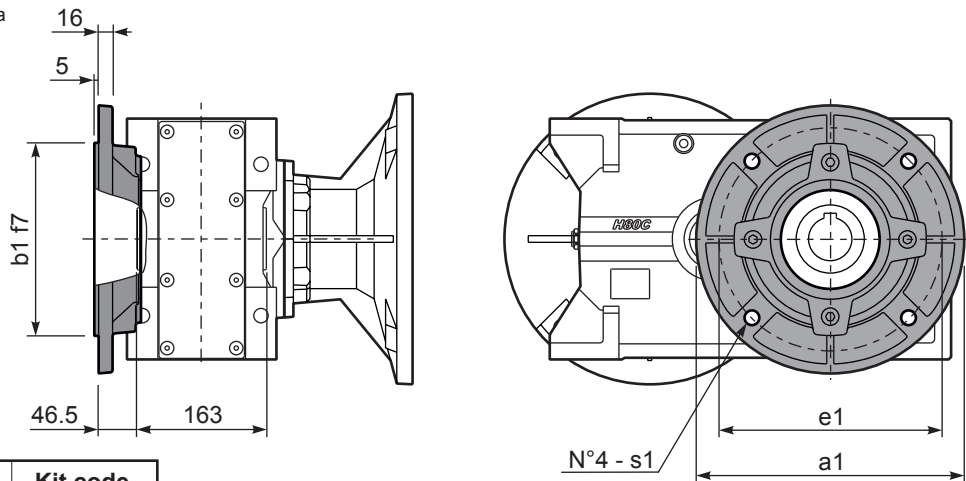

Available output flanges

Flange di uscita

a1 $\phi$	b1	e1	s1	Kit code
300	230	265	14	KF80.9.011
350	250	300	18	KF80.9.012
400	300	350	18	KF80.9.013

**PH81C...-N**

Feet  
Piedini

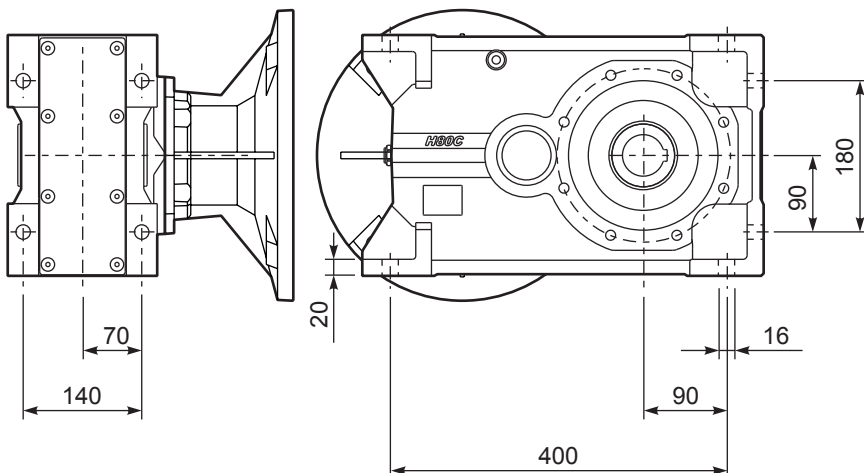

**PH81C A...**

Single output shaft  
Albero uscita semplice

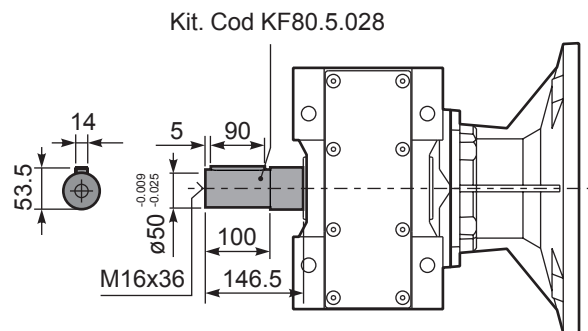

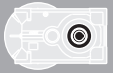

## QUICK SELECTION / Selezione veloce

input speed ( $n_1$ ) = 1400 min<sup>-1</sup>

Output Speed $n_2$ [min <sup>-1</sup> ]	Ratio $i$	Motor power $P_{1M}$ [kW]	Output torque $M_{2M}$ [Nm]	Service factor $f.s.$	Nominal power $P_{1R}$ [kW]	Nominal torque $M_{2R}$ [Nm]	B5 motor flanges				B14 motor flanges				Output Shaft 	Ratios code 
							-F	-G	-H	-I	-	-	-	-		
							100 112	132	160	180	-	-	-	-		
234	<b>5.98</b>	22	827	1.2	<b>25.5</b>	<b>1000</b>	B							3015	standard ø50  ø55 On request	01
197	<b>7.10</b>	22	982	1.2	<b>25.3</b>	<b>1175</b>	B							3013		02
162	<b>8.63</b>	22	1193	1.1	<b>23.9</b>	<b>1350</b>	B							3011		03
124	<b>11.27</b>	18.5	1310	1.1	<b>20.3</b>	<b>1500</b>	B							2015		04
105	<b>13.38</b>	18.5	1555	1.1	<b>19.4</b>	<b>1700</b>	B							2013		05
92	<b>15.24</b>	18.5	1771	1.1	<b>19.0</b>	<b>1900</b>	B							1615		06
86	<b>16.26</b>	18.5	1889	1.1	<b>19.7</b>	<b>2100</b>	B							2011		07
77	<b>18.09</b>	18.5	2102	1.0	<b>17.7</b>	<b>2100</b>	B							1613		08
71	<b>19.82</b>	15	1865	1.1	<b>15.9</b>	<b>2060</b>	B							1315		09
64	<b>21.98</b>	15	2069	1.0	<b>14.6</b>	<b>2100</b>	B							1611		10
60	<b>23.53</b>	15	2214	0.9	<b>13.6</b>	<b>2100</b>	B							1313		11
58	<b>24.25</b>	11	1677	1.2	<b>12.2</b>	<b>1940</b>	B							1115		12
48.6	<b>28.80</b>	11	1991	1.1	<b>11.1</b>	<b>2100</b>	B							1113		13
40.0	<b>34.99</b>	9	2063	1.0	<b>9.2</b>	<b>2100</b>	B							1111		14
33.6	<b>41.64</b>	7.5	1976	1.0	<b>7.2</b>	<b>1960</b>	B							813		15
27.7	<b>50.60</b>	5.5	1774	1.2	<b>6.3</b>	<b>2100</b>	B							811		16

The dynamic efficiency is **0.96** for all ratios

Motor Flanges Available  
Flange Motore Disponibili

Supplied with Reduction Bushing  
Fornito con Bussola di Riduzione

Available on Request without reduction bushing  
Disponibile a Richiesta senza Bussola di Riduzione

Motor Flange Holes Position  
Posizione Fori Flangia Motore

**EN** Unit **H82C** is supplied without lubricant and equipped with a breather, level and drain plugs. User can add mineral oil keeping existing plugs. Should the user wish to fill it with synthetic oil, it is recommended to replace the existing plugs with a closed plug.  
See table 1 for lubrication and recommended quantity. In table 2 please see possible radial loads and axial loads on the gearbox.

**I** Il riduttore tipo **H82C** è fornito privo di lubrificazione con tappi di sfiato, livello e scarico olio. L'utente può immettere olio minerale mantenendo i tappi esistenti. Se immetterà olio sintetico, dovrà sostituire i tappi esistenti con altri tipo chiuso.  
Tab.1 per oli e quantità consigliati.  
Tab.2 carichi radiali e assiali applicabili al riduttore.

**D** Das Getriebe der Baugröße **H82C** wird ohne Schmiermittel geliefert. Es ist jedoch mit Einfüllschraube, Überdruckventil und Ablassschraube ausgerüstet. Das benötigte mineralische Öl kann über die Einfüllschraube eingefüllt werden. Sollte synthetisches Öl bevorzugt werden, so ist sind das eingebaute Überdruckventil durch eine geschlossenen Schraube zu ersetzen.  
In Tabelle 1 ist die Schmiermenge und das empfohlene Schmiermittel angegeben  
In Tabelle 2 sind die zulässigen Radial - und Axialbelastungen des Getriebes aufgeführt.

**F** Le réducteur de type **H82C** est fourni sans lubrification et avec un bouchon de remplissage, de niveau et d'évacuation de l'huile. L'utilisateur peut y verser de l'huile minérale en conservant les bouchons existants. S'il y versera de l'huile synthétique, il devra substituer les bouchons existants avec d'autres bouchons de type fermé.  
Voir tableau 1 concernant les huiles et les quantités conseillées.  
Voir tableau 2 concernant les charges radiales et axiales applicables au réducteur

**E** El reductor tamaño **H82C** se suministra sin lubricante, provisto de tapones de respiración, nivel y descarga de aceite. El usuario puede utilizar aceite mineral, manteniendo los tapones existentes. Si prefiere utilizar aceite sintético deberá sustituir los tapones existentes por tapones ciegos. La prerreducción se suministra con tapones ciegos, lubricado de por vida con aceite sintético. Ver tabla 1, para cantidades y aceites recomendados. En la tabla 2, se encuentran las cargas radiales y axiales admitidas por el reductor.

B3	B6	B7	B8	V5	V6	V8
5.60 LT	6.80 LT	7.80 LT	5.60 LT	10.00 LT	5.50 LT	Ask

AGIP Blasia 460

For all details on lubrication and plugs check our website **tab. 1**  
Per maggiori dettagli su lubrificazione e tappi olio vedi il nostro sito web

### RADIAL AND AXIAL LOADS

**Output shaft**  
Albero di uscita

$F_{eq} = F_R \cdot \frac{227.5}{X+177.5}$

$n_2$	FA	FR	$n_2$	FA	FR	$n_2$	FA	FR
<b>300</b>	920	4600	<b>140</b>	1120	5600	<b>70</b>	1400	7000
<b>250</b>	1000	5000	<b>120</b>	1140	5700	<b>40</b>	1800	9000
<b>200</b>	1060	5300	<b>85</b>	1300	6500	<b>15</b>	2400	12000

**On request reinforced bearings to increase loads.**  
A richiesta cuscinetti rinforzati per aumentare i carichi.

**Input shaft**  
Albero in entrata

$n_1$	FA	FR
<b>1400</b>	700	3500
<b>900</b>	840	4200
<b>500</b>	900	4500

tab. 2

**PH82C...**

Basic gearbox  
Riduttore base

Gearbox weight  
peso riduttore **86.0 kg**

M. flanges	Kit code	øF	A
100/112B5	-	250	337.5
132B5	-	300	341.5
160/180B5	-	350	352.5

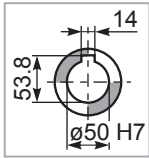

**Standard**  
Hollow shaft

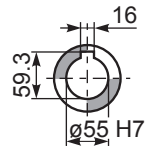

**On request**  
A richiesta

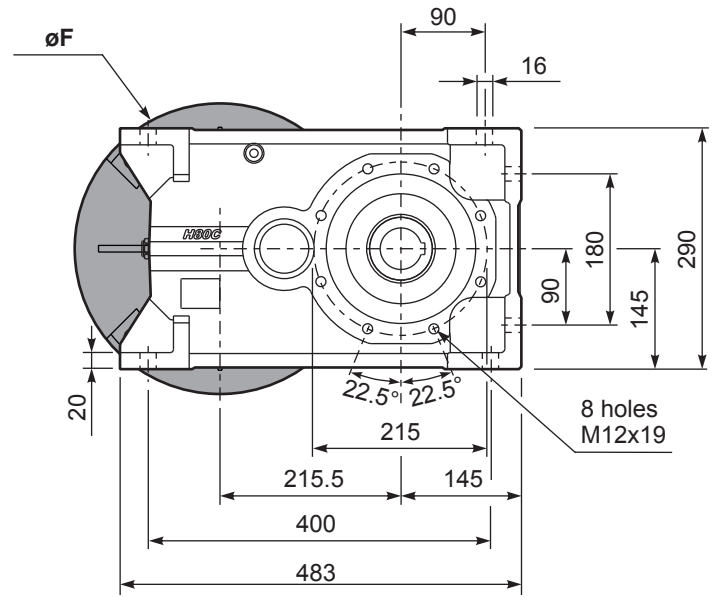
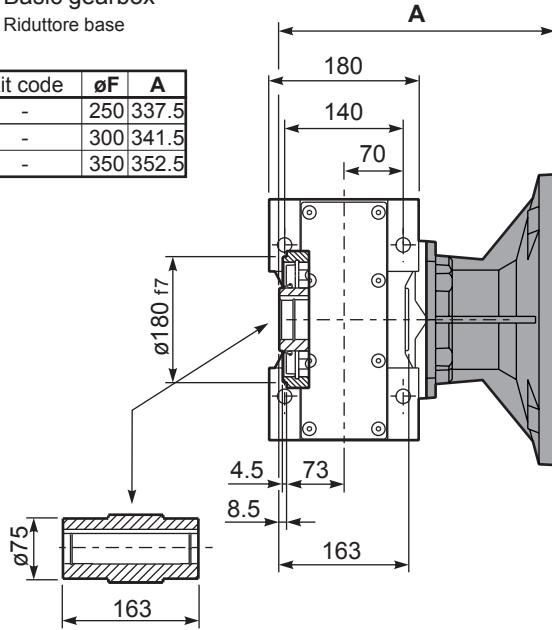

**PH82C...-F**

Output flange  
Flangia uscita

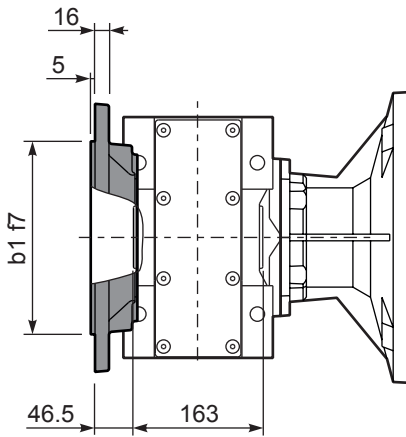

**Available output flanges**

Flange di uscita

a1 ø	b1	e1	s1	Kit code
300	230	265	14	KF80.9.011
350	250	300	18	KF80.9.012
400	300	350	18	KF80.9.013

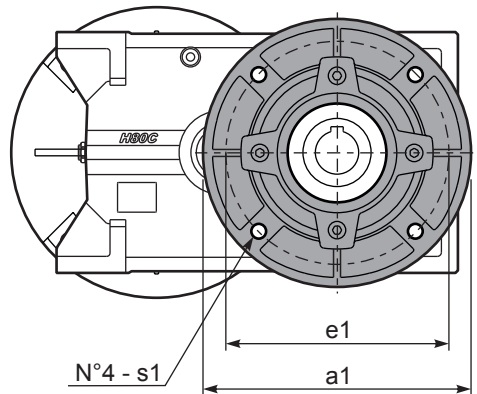

**PH82C D...**

Shrink disk  
Calettatore

Kit. Cod KF80.0.210LM

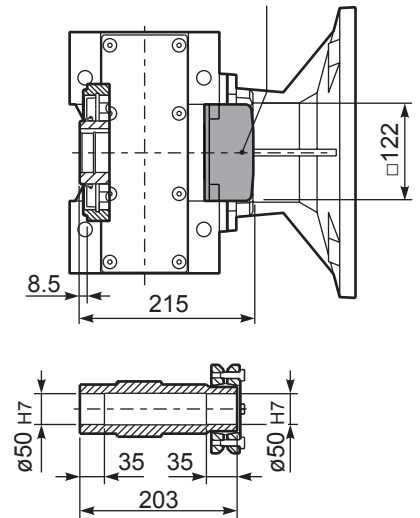

**RH82C...**

Input Shaft  
Albero in entrata

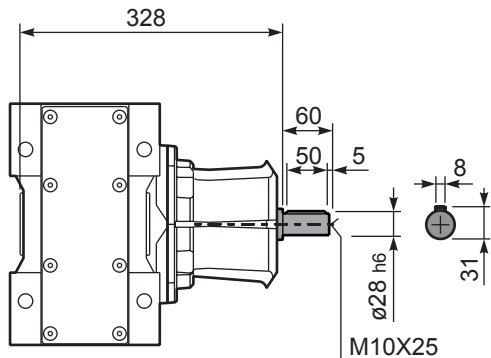

**PH82C A...**

Single output shaft  
Albero uscita semplice

Kit. Cod KF80.5.028

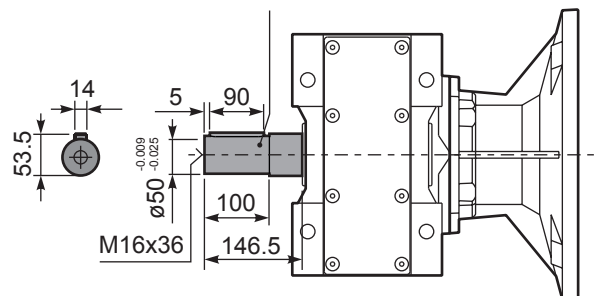



## QUICK SELECTION / Selezione veloce

input speed ( $n_1$ ) = 1400 min<sup>-1</sup>

Output Speed $n_2$ [min <sup>-1</sup> ]	Ratio $i$	Motor power $P_{1M}$ [kW]	Output torque $M_{2M}$ [Nm]	Service factor f.s.	Nominal power $P_{1R}$ [kW]	Nominal torque $M_{2R}$ [Nm]	Available B5 motor flanges					Available B14 motor flanges				Output Shaft 	Ratios code
							-C	-D	-E	-F	-G	-R	-T	-U	-V		
							71	80	90	100 112	132	80	90	100 112	132		
28.8	<b>48.55</b>	7.5	2257	0.9	6.7	2100	B									201315	01
24.3	<b>57.64</b>	5.5	1980	1.1	5.7	2100	B									201313	02
21.3	<b>65.64</b>	5.5	2255	0.9	5.0	2100	B									161315	03
20.0	<b>70.04</b>	4	1760	1.2	4.7	2100	B									201311	04
18.0	<b>77.93</b>	4	1958	1.1	4.2	2100	B									161313	05
16.4	<b>85.36</b>	4	2145	1.0	3.8	2100	B									131315	06
14.8	<b>94.70</b>	4	2380	0.9	3.5	2100	B									161311	07
13.8	<b>101.35</b>	3	1917	1.1	3.2	2100	B									131313	08
11.4	<b>123.15</b>	3	2330	0.9	2.7	2100	B									131311	09
9.3	<b>150.73</b>	2.2	2100	1.0	2.2	2100	B									111311	10
7.8	<b>179.39</b>	1.5	1722	1.2	1.8	2100	B									81313	11
6.4	<b>217.98</b>	1.5	2093	1.0	1.5	2100	B									81311	12
5.7	<b>247.03</b>	1.1	1732	1.1	1.2	1950	B									61313	13
4.7	<b>300.17</b>	1.1	2105	1.0	1.1	2100	B									61311	14

The dynamic efficiency is **0.94** for all ratios

Motor Flanges Available  
Flange Motore Disponibili

B) Supplied with Reduction Bushing  
Fornito con Bussola di Riduzione

B) Available on Request without reduction bushing  
Disponibile a Richiesta senza Bussola di Riduzione

C) Motor Flange Holes Position  
Posizione Fori Flangia Motore

**EN** Unit H83C is supplied without lubricant and equipped with a breather, level and drain plugs. User can add mineral oil keeping existing plugs. Should the user wish to fill it with synthetic oil, it is recommended to replace the existing plugs with a closed plug.  
See table 1 for lubrication and recommended quantity. In table 2 please see possible radial loads and axial loads on the gearbox.

**I** Il riduttore tipo H83C è fornito privo di lubrificazione con tappi di sfiato, livello e scarico olio. L'utente può immettere olio minerale mantenendo i tappi esistenti. Se immetterà olio sintetico, dovrà sostituire i tappi esistenti con altri tipo chiuso.  
Tab.1 per oli e quantità consigliati.  
Tab.2 carichi radiali e assiali applicabili al riduttore.

**D** Das Getriebe der Baugröße H83C wird ohne Schmiermittel geliefert. Es ist jedoch mit Einfüllschraube, Überdruckventil und Ablassschraube ausgerüstet. Das benötigte mineralische Öl kann über die Einfüllschraube eingefüllt werden. Sollte synthetisches Öl bevorzugt werden, so ist sind das eingebaute Überdruckventil durch eine geschlossenen Schraube zu ersetzen.  
In Tabelle 1 ist die Schmiermenge und das empfohlene Schmiermittel angegeben  
In Tabelle 2 sind die zulässigen Radial - und Axialbelastungen des Getriebes aufgeführt.

**F** Le réducteur de type H83C est fourni sans lubrification et avec un bouchon de remplissage, de niveau et d'évacuation de l'huile. L'utilisateur peut y verser de l'huile minérale en conservant les bouchons existants. S'il y versera de l'huile synthétique, il devra substituer les bouchons existants avec d'autres bouchons de type fermé.  
Voir tableau 1 concernant les huiles et les quantités conseillées.  
Voir tableau 2 concernant les charges radiales et axiales applicables au réducteur

**E** El reductor tamaño H83C se suministra sin lubricante, provisto de tapones de respiración, nivel y descarga de aceite. El usuario puede utilizar aceite mineral, manteniendo los tapones existentes. Si prefiere utilizar aceite sintético deberá sustituir los tapones existentes por tapones ciegos. La prerreducción se suministra con tapones ciegos, lubricado de por vida con aceite sintético. Ver tabla 1, para cantidades y aceites recomendados. En la tabla 2, se encuentran las cargas radiales y axiales admitidas por el reductor.

B3	B6	B7	B8	V5	V6	V8
5.80 LT	7.10 LT	8.20 LT	5.80 LT	10.80 LT	6.00 LT	Ask

**AGIP Blasias 460**

For all details on lubrication and plugs check our website **tab. 1**  
Per maggiori dettagli su lubrificazione e tappi olio vedi il nostro sito web

### RADIAL AND AXIAL LOADS

**Output shaft**  
Albero di uscita

$F_{eq} = F_R \cdot \frac{227.5}{X+177.5}$

$n_2$	FA	FR	$n_2$	FA	FR	$n_2$	FA	FR
300	920	4600	140	1120	5600	70	1400	7000
250	1000	5000	120	1140	5700	40	1800	9000
200	1060	5300	85	1300	6500	15	2400	12000

**On request reinforced bearings to increase loads.**  
A richiesta cuscinetti rinforzati per aumentare i carichi.

**Input shaft**  
Albero in entrata

$n_1$	FA	FR
1400	450	2250
900	500	2500
500	600	3000

**tab. 2**



**PH83C...**

Basic gearbox  
Riduttore base

Gearbox weight  
peso riduttore **81.0 kg**

M. flanges	Kit code	øF	A
71B5	K023.4.041	160	292.5
80/90B5	K023.4.042	200	294.5
100/112B5	K023.4.043	250	303.5
132B5	KC50.4.043	300	321.5
80B14	K085.4.046	120	294.5
90B14	K085.4.045	140	294.5
100/112B14	K085.4.047	160	303.5
132B14	KC50.4.041	200	321.5

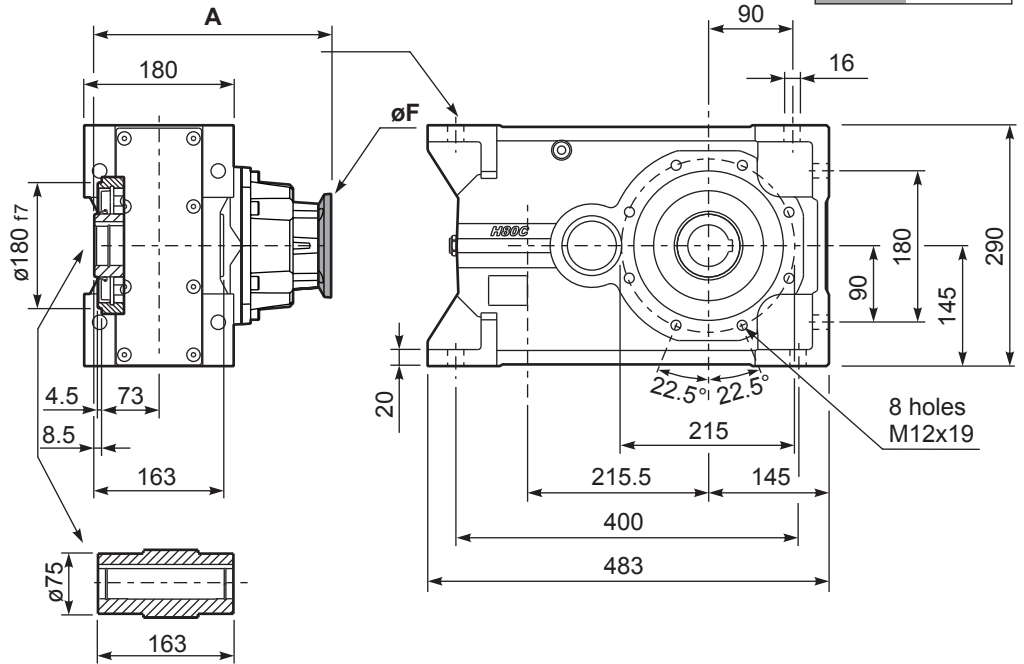

**Standard**  
Hollow shaft

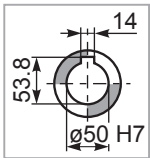

**On request**  
A richiesta

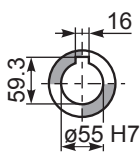

**PH83C...-F**

Output flange  
Flangia uscita

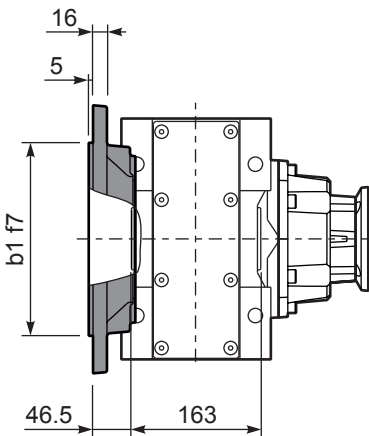

**Available output flanges**  
Flange di uscita

a1 ø	b1	e1	s1	Kit code
300	230	265	14	KF80.9.011
350	250	300	18	KF80.9.012
400	300	350	18	KF80.9.013

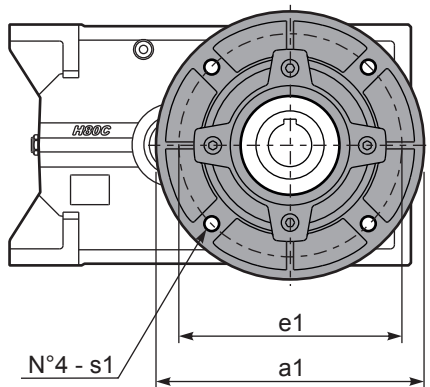

**PH83C D...**

Shrink disk  
Calettatore

Kit. Cod KF80.0.210LM

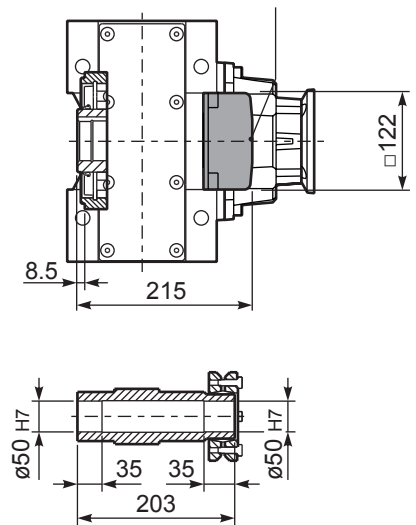

**RH83C...**

Input Shaft  
Albero in entrata

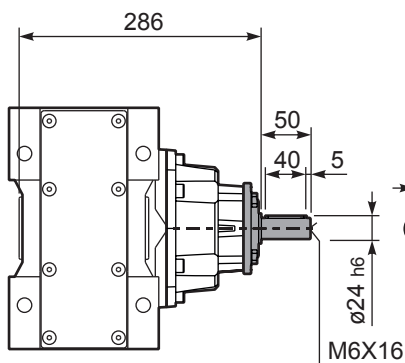

**PH83C A...**

Single output shaft  
Albero uscita semplice

Kit. Cod KF80.5.028

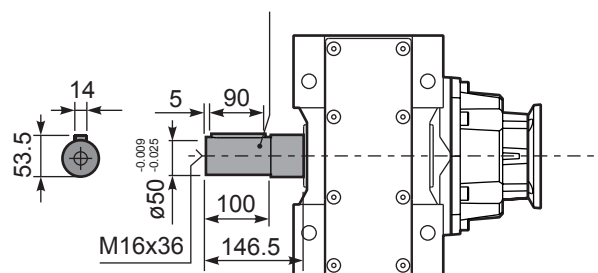





- 1) 230/400V - 50Hz three-phase asynchronous induction motor
- 2) Class F insulation
- 3) S1 duty
- 4) IP 55 protection
- 5) Not painted
- 6) Hard plastic sleeve to protect output shaft during the transportation

- 1) 230/400V - 50Hz motore trifase asincrono
- 2) Isolamento Classe F
- 3) S1 servizio continuo
- 4) Protezione IP 55
- 5) Non verniciato
- 6) Manicotto di protezione per l'albero motore

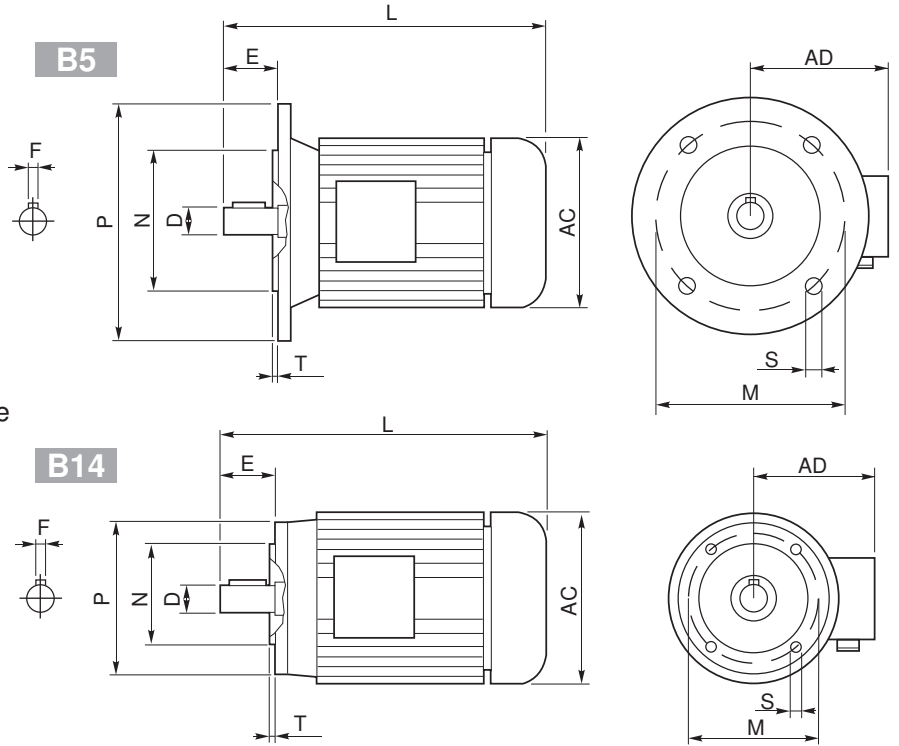

Outside dimensions and weight may be different according to manufacturers.  
 Le dimensioni esterne e il peso sono indicative, possono variare tra i vari costruttori.

	2 poli / poles			4 poli / poles			6 poli / poles			B5-B14					B5					B14					Kg	
	kW	Nm	A <sub>(400V)</sub>	kW	Nm	A <sub>(400V)</sub>	kW	Nm	A <sub>(400V)</sub>	D	F	E	L	AC	AD	N	M	P	S	T	N	M	P	S		T
56 A	0.09	0.32	0.38	0.06	0.44	0.27	—	—	—	9	3	20	199	108	96	80	100	120	7	2.5	50	65	80	M5	2.5	2.7
56 B	0.12	0.42	0.46	0.09	0.67	0.37	—	—	—	9	3	20	199	108	96	80	100	120	7	2.5	50	65	80	M5	2.5	2.9
63 A	0.18	0.63	0.60	0.12	0.84	0.50	0.09	0.99	0.57	11	4	23	208	120	99	95	115	140	9.5	3	60	75	90	M5	2.5	3.8
63 B	0.25	0.87	0.76	0.18	1.30	0.69	0.12	1.32	0.74	11	4	23	208	120	99	95	115	140	9.5	3	60	75	90	M5	2.5	4.2
71 A	0.37	1.30	1.00	0.25	1.70	0.91	0.18	1.90	0.80	14	5	30	-	130	104	110	130	160	9.5	3.5	70	85	105	M6	2.5	5.9
71 B	0.55	1.90	1.54	0.37	2.52	1.14	0.25	2.72	1.10	14	5	30	255	141	107	110	130	160	9.5	3.5	70	85	105	M6	2.5	6.5
80 A	0.75	2.60	1.85	0.55	3.77	1.51	0.37	3.84	1.18	19	6	40	296	159	127	130	165	200	11.5	3.5	80	100	120	M6	3	8.5
80 B	1.1	3.90	2.64	0.75	5.11	2.57	0.55	5.84	1.80	19	6	40	296	159	127	130	165	200	11.5	3.5	80	100	120	M6	3	10
90 S	1.5	5.00	3.31	1.1	7.45	2.78	0.75	7.92	2.32	24	8	50	-	170	135	130	165	200	11.5	3.5	95	115	140	M8	3	12.5
90 L	2.2	7.50	4.46	1.5	10.2	3.61	1.1	11.6	3.45	24	8	50	330	170	135	130	165	200	11.5	3.5	95	115	140	M8	3	15
100 LA	3.0	10.0	6.28	2.2	14.8	5.07	1.5	15.4	3.88	28	8	60	-	190	148	180	215	250	13	4	110	130	160	M8	3.5	20
100 LB	—	—	—	3.0	20.1	6.66	—	—	—	28	8	60	-	190	148	180	215	250	13	4	110	130	160	M8	3.5	22
112 M	4.0	13.4	8.10	4.0	26.7	8.55	2.2	22.6	5.30	28	8	60	381	210	164	180	215	250	13	4	110	130	160	M8	3.5	35
132 S	5.5	18.3	11.2	5.5	36.5	11.4	3.0	30.2	7.20	38	10	80	455	244	180	230	265	300	14	4	130	165	200	M10	4	41
	7.5	24.9	15.3																							51
132 M	—	—	—	7.5	49.4	15.0	4.0	40.0	9.13	38	10	80	500	244	180	230	265	300	14	4	130	165	200	M10	4	51
	9	61.4	18.5	51																						
160 M	—	—	—	11	72	21.5	—	—	—	42	12	110	613	335	246	250	300	350	18	5	—	—	—	—	—	79.2
160 L	—	—	—	15	98	29	—	—	—	42	12	110	657	335	246	250	300	350	18	5	—	—	—	—	—	97.5
180 M	—	—	—	18.5	121	35.5	—	—	—	48	14	110	712	366	266	250	300	350	19	5	—	—	—	—	—	170
180 L	—	—	—	22	144	42	—	—	—	48	14	110	712	366	266	250	300	350	19	5	—	—	—	—	—	170
200 L	—	—	—	30	196	53	—	—	—	55	16	110	780	405	341	300	350	400	19	5	—	—	—	—	—	240
225 S	—	—	—	37	240	69	—	—	—	60	18	140	888	463	360	350	400	450	19	5	—	—	—	—	—	305
225 M	—	—	—	45	292	84	—	—	—	60	18	140	888	463	360	350	400	450	19	5	—	—	—	—	—	310



**Protection**

Standard IP55  
Please specify on purchase orders if you need a higher IP protection class.

**Grado di protezione**

IP55 Standard  
Specificare in sede di ordinazione per IP superiore.

**Schutzart**

IP55 Standard.  
Höheren IP Grad bitte im Auftrag angeben.

**Degré de protection**

IP55 standard.  
Au moment de la commande, spécifiez si vous souhaitez IP supérieur.

**Grado de protección**  
IP55 standard.  
Especificar en el pedido cuando necesiten protección IP superior.

**Insulation**

Standard Cl.F  
To be specified upon placing the order if different insulation is required.

**Isolamento**

Cl.F Standard  
Specificare in sede di ordinazione classe di isolamento diversa.

**Isolierung**

Cl.F Standard.  
Davon abweichende Isolierungsklasse im Auftrag angeben.

**Isolement**

Cl.F Standard.  
Au moment de la commande, spécifiez si vous souhaitez une classe d'isolement différente.

**Aislamiento**

Cl.F standard.  
Especificar al efectuar el pedido la clase diferente de aislamiento.

Insulation / Isolamento Isolierung /Aislamiento		E	B	F	H
Max. temp.	C°	120°	130°	155°	175°
	F*	248°	266°	311°	347°

**Connections**

**Collegamenti**

**Verbindungselemente**

**Branchements**

**Conexiones**

Threephase asynchronous single polarity  
Asincrono trifase singola polarità  
Asynchronmotor 3-ph eine Drehzahl  
Moteur triphasé à une vitesse  
Asincrono trifasico de una velocidad

Threephase asynchronous double polarity  
Asincrono trifase doppia polarità  
Asynchronmotor 3-ph doppelte Drehzahl  
Moteur triphasé à deux vitesses  
Asincrono trifasico de dos velocidades

Single phase asynchronous  
Asincrono monofase  
Einphasen-Asynchronmotor  
Moteur monophasé  
Asincrono monofasico

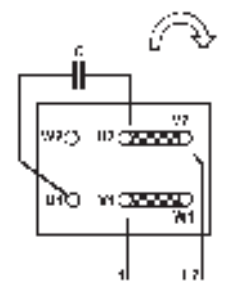
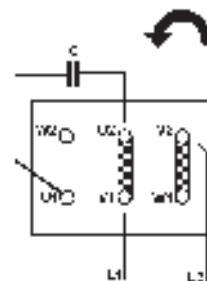
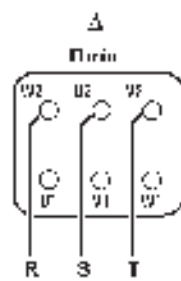
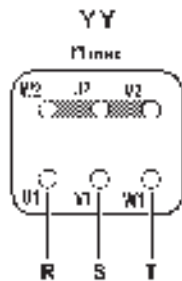
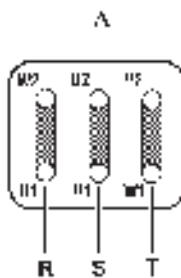
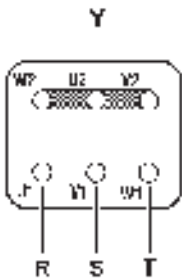





### Please Read Carefully

The following WARNING and CAUTION information is supplied to you for your protection and to provide you with many years of trouble free and safe operation of your product.

Read ALL instructions prior to operating reducer. Injury to personnel or reducer failure may be caused by improper installation, maintenance or operation.

### WARNING:

- Written authorization is required to operate or use reducers in man lift or people moving devices.
- Check to make sure that certain applications do not exceed the allowable load capacities published in the current catalog.
- Buyer shall be solely responsible for determining the adequacy of the product for any and all uses to which Buyer shall apply the product. The application by Buyer shall not be subject to any implied warranty of fitness for a particular purpose.
- For safety, Buyer or User should provide protective guards over all shaft extensions and any moving apparatus mounted thereon. The User is responsible for checking all applicable safety codes in his area and providing suitable guards. Failure to do so may result in bodily injury and/or damage to equipment.
- Gearboxes operating in high position should have a protective shield for any possible parts falling down for casual accidents where people are moving under them.
- Hot oil and reducers can cause severe burns. Use extreme care when removing lubrication plugs and vents.
- Make certain that the power supply is disconnected before attempting to service or remove any components. Lock out the power supply and tag it to prevent unexpected application power.
- Reducers are not to be considered fail safe or self-locking devices. If these features are required, a properly sized, independent holding device should be utilized. Reducers should not be used as a brake.
- Any brakes that are used in conjunction with a reducer must be sized or positioned in such a way so as to not subject the reducer to loads beyond the catalog rating.
- Lifting supports including eyebolts are to be used for vertically lifting the gearbox only and not other associated attachments or motors.
- Use of an oil with an EP additive on units with backstops may prevent proper operation of the backstop. Injury to personnel, damage to the reducer or other equipment may result.
- Overhung loads subject shaft bearings and shafts to stress which may cause premature bearing failure and or shaft breakage from bending fatigue, if not sized properly.

### SELLING CONDITIONS

Warranty for manufacturing defects will expire one-year the invoicing date. Hydro-Mec will replace or repair defective parts but will not accept any further changes for direct or indirect damages of any kind. The warranty will become null and void if repairs or changes are carried out without our prior written authorization.

**Our company will not be responsible for any direct or indirect damages, caused by a wrong use of the products or for not observing the catalogue/web indication**

### Leggere attentamente

Le seguenti raccomandazioni sono fondamentali per la vostra protezione e per garantirvi molti anni di sicuro funzionamento del vostro prodotto senza alcun problema.

Leggere attentamente tutte le istruzioni prima di azionare il riduttore. L'inappropriata installazione, manutenzione o funzionamento del riduttore può causare incidenti al personale addetto e danni al riduttore stesso.

### ATTENZIONE:

- E' richiesta autorizzazione scritta per azionare riduttori in ascensori o dispositivi per il movimento delle persone.
- Controllare che alcune applicazioni non eccedano la massima capacità di carico ammessa pubblicata in questo catalogo.
- L'acquirente è l'unico responsabile per la determinazione dell'adeguatezza del prodotto per qualcuna o tutte le utilizzazioni che l'acquirente stesso farà del riduttore. L'applicazione dell'acquirente non potrà essere soggetta ad alcuna implicita garanzia di montaggio per uno scopo particolare.
- Per ragioni di sicurezza l'acquirente dovrà provvedere a porre protezioni adeguate su tutta la lunghezza dell'albero a tutti gli organi in movimento. L'utilizzatore è responsabile del controllo di tutti i codici di sicurezza e la predisposizione di protezioni adeguate. In assenza di tali precauzioni si possono verificare incidenti alle persone e danni agli apparati.
- Su riduttori installati in posizioni elevate utilizzare protezioni adeguate per qualsiasi distacco accidentale di parti nel caso di passaggio di persone al di sotto.
- Olio e riduttori bollenti possono causare gravi ustioni. Usare estrema cautela nella rimozione dei tappi e delle ventole.
- Assicurarsi che la corrente di alimentazione sia scollegata prima di riparare o rimuovere alcun componente. Chiudere l'alimentazione e contrassegnare tale operazione per evitare accensioni accidentali.
- I riduttori non devono essere considerati esenti da guasti o a bloccaggio automatico. Se sono indispensabili queste caratteristiche, deve essere utilizzato un dispositivo indipendente della dimensione adatta. I riduttori non devono essere utilizzati come freni.
- Qualsiasi freno sia utilizzato insieme al riduttore deve essere della giusta grandezza e posizionato in modo da non causare carichi eccessivi non previsti dai dati forniti nel catalogo.
- I dispositivi di sollevamento come le golfare devono essere usati solo per sollevare verticalmente il riduttore e non altri dispositivi associati o motori.
- L'utilizzo di un olio con un additivo EP su gruppi provvisti di dispositivo di arresto possono inficiare l'uso corretto del freno e provocare danni alle persone, alle cose ed al riduttore stesso nonché ad altri apparecchi.
- I Carichi sospesi assoggettano i cuscinetti della vite e la vite stessa a sollecitazioni che possono causare, se non adeguatamente dimensionati, l'usura prematura dei cuscinetti e/o la rottura della vite a causa della resistenza alla flessione.

### CONDIZIONI DI VENDITA

La garanzia relativa a difetti di costruzione ha la durata di un anno dalla data di fatturazione della merce. Tale garanzia comporta per Hydro-mec l'onere della sostituzione o riparazione delle parti difettose ma non ammette ulteriori addebiti per eventuali danni diretti o indiretti di qualsiasi natura.

La garanzia decade nel caso in cui siano state eseguite riparazioni o apportate modifiche senza nostro consenso scritto.

**La nostra ditta non si ritiene responsabile per eventuali danni diretti o indiretti derivanti da un uso improprio dei prodotti e dalla mancata osservanza delle indicazioni riportate a catalogo o web..**





## ***Others HYDRO-MEC products***



Worm gearboxes  
Rid. a vite senza fine



Square worm gearboxes  
Rid. a vite senza fine quadro

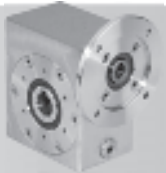

Stainless steel worm gearboxes  
Rid. a vite senza fine Inox



Stainless steel one step gearbox  
Riduttore uno stadio Inox



Helical bevel gearboxes  
Rid. a coppia conica

## ***HYDRO-MEC***

Via della tecnica, 19  
36050 SOVIZZO (VI) ITALY  
Tel.: +39 0444 551911  
Fax: +39 0444 536139  
e-mail: [hydromec@hydromec.com](mailto:hydromec@hydromec.com)  
Website: [www.hydromec.com](http://www.hydromec.com)

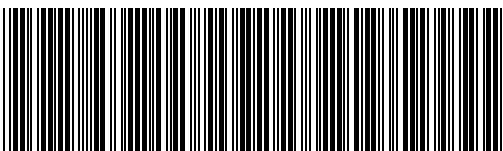

\* CT - RFX - FC - HM017

## ***Distributed From:***

