



### QUICK SELECTION / Selezione veloce

input speed ( $n_1$ ) = 1400 min<sup>-1</sup>

Output Speed $n_2$ [min <sup>-1</sup> ]	Ratio $i$	Motor power $P_{1M}$ [kW]	Output torque $M_{2M}$ [Nm]	Service factor f.s.	Nominal power $P_{1R}$ [kW]	Nominal torque $M_{2R}$ [Nm]	Available B5 motor flanges			Available B14 motor flanges		Dynamic efficiency <b>RD</b>	Tooth Module  [mm]	Ratios code 
							-A	-B	-C	-P	-Q			
							56	63	71	63	71			
47	<b>30.1</b>	0.37	58	1.3	<b>0.49</b>	77				C		76	2.5	01
33	<b>43.0</b>	0.25	55	1.4	<b>0.35</b>	77				C		75	2.4	02
23	<b>60.2</b>	0.25	71	1.1	<b>0.27</b>	77				C		69	2.6	03
18.1	<b>77.4</b>	0.25	81	1.1	<b>0.27</b>	88				C		61	2.0	04
12.5	<b>112</b>	0.18	84	1.1	<b>0.19</b>	88				C		61	2.7	05
9.0	<b>155</b>	0.12	71	1.2	<b>0.15</b>	88				C		56	2.1	06
7.6	<b>185</b>	0.12	74	1.0	<b>0.12</b>	77				C		49	1.8	07
5.4	<b>258</b>	0.12*	77	<0.8	<b>0.09</b>	77				C		47	1.3	08
4.8	<b>292</b>	0.12*	66	<0.8	<b>0.08</b>	66				C		44	1.2	09
4.1	<b>344</b>	0.12*	44	<0.8	<b>0.05</b>	44				C		40	1.0	10
3.3	<b>430</b>	0.12*	44	<0.8	<b>0.04</b>	44				C		36	0.8	11

**A) Motor Flanges Available**  
Flange Motore Disponibili

**B) Supplied with Reduction Bushing**  
Fornito con Bussola di Riduzione

**B) Available on Request without reduction bushing**  
Disponibile a Richiesta senza Bussola di Riduzione

**C) Motor Flange Holes Position**  
Posizione Fori Flangia Motore

\* Power higher than the maximum one which can be supported by the gearbox. Select according to the torque  $M_{2R}$   
Potenza superiore a quella massima sopportabile dal riduttore. Selezionare in base al momento torcente  $M_{2R}$

**EN** Unit **P5Q** is supplied with synthetic oil, providing "long life" lubrication. For mounting position V5-V6 please contact us. See table 1 for lubrication and recommended quantity. In table 2 please see possible radial loads and axial loads on the gearbox.

**I** Il riduttore tipo **P5Q** viene fornito lubrificato a vita con olio sintetico. Per posizioni V5-V6 contattare il ns. servizio tecnico. Vedi tab.1 per oli e quantità consigliati. In tab.2 sono presenti i carichi radiali e assiali applicabili al riduttore.

**D** Für die Lebensdauerschmierung ist das Getriebe der Größe **P5Q** mit synthetischem Öl befüllt. Bei Einbaulage V5 oder V6 bitten wir um Rücksprache. In Tabelle 1 ist die Schmiermenge und das empfohlene Schmiermittel angegeben. In Tabelle 2 sind die zulässigen Radial- und Axialbelastungen des Getriebes aufgeführt.

**F** Le réducteur de type **P5Q** est fourni lubrifié à vie avec de l'huile synthétique. Concernant les positions V5.V6, contactez notre service d'assistance technique. Voir tableau 1 concernant les huiles et les quantités conseillées. Les charges radiales et axiales applicables au réducteur sont précisées dans le tableau 2.

**E** El reductor tamaño **P5Q** se suministra, lubricado de por vida con aceite sintético. Para las posiciones V5 y V6 contactar con nuestro servicio técnico. Ver tabla 1, para cantidades y aceites recomendados. En la tabla 2, se encuentran las cargas radiales y axiales admitidas por el reductor.

**■ LUBRICATION P5Q Oil**  
Common lubrication 0.26 l ( A + B ).

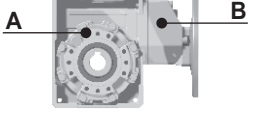

<b>AGIP</b> Telium VSF 320	<b>SHELL</b> Omala S4 WE 320
----------------------------	------------------------------

For all details on lubrication and plugs check our website **tab. 1**  
Per maggiori dettagli su lubrificazione e tappi olio vedi il nostro sito web

### ■ RADIAL AND AXIAL LOADS

**Output shaft**  
Albero di uscita

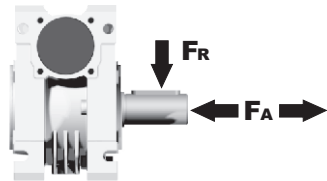

$n_2$ [min <sup>-1</sup> ]	FA [N]	FR [N]
75	340	1700
50	380	1900
25	480	2500
15-6	560	2800

**Input shaft**  
albero in entrata

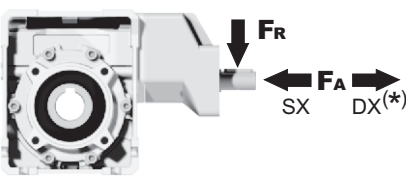

$n_1$ [min <sup>-1</sup> ]	FA [N]	FR [N]
1400	44	220

**\*Strong axial loads in the DX direction are not allowed.**  
Non sono consentiti forti carichi assiali con direzione DX

**tab. 2**

**PP5QFB...** Basic wormbox  
Riduttore base

M. flanges	Kit code	øF	A
56B5	K050.4.046	120	147
63B5	K050.4.041	138	149
71B5	K050.4.042	160	146.5
63B14	K050.4.047	90	149
71B14	K050.4.045	105	146.5

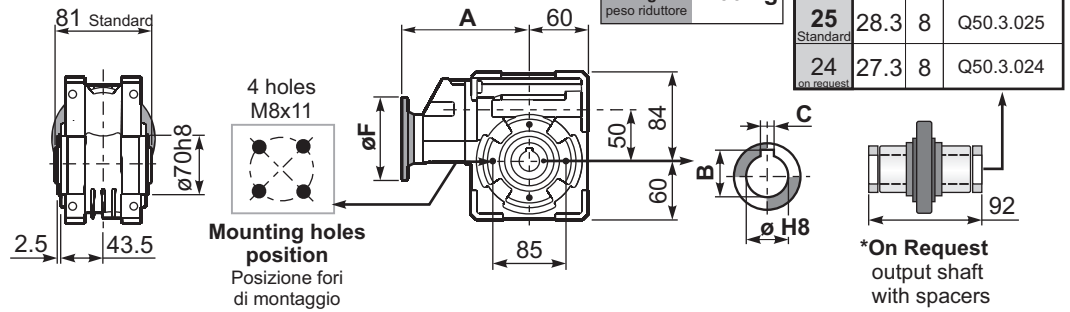

**PP5QFC...** Square flange  
Flangia quadrata

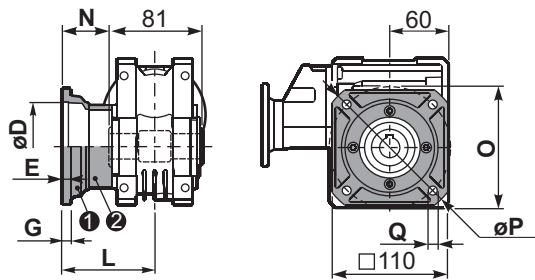

type B	øD	E	G	L	N	O	P	Q	kit code
FC	70 H8	5	9	90	49.5	85	125	11	KQ50.9.010
FL	70 H8	5	9	120	79.5	85	125	11	KQ50.9.011

**PP5QF1...** Round flange  
Flangia rotonda

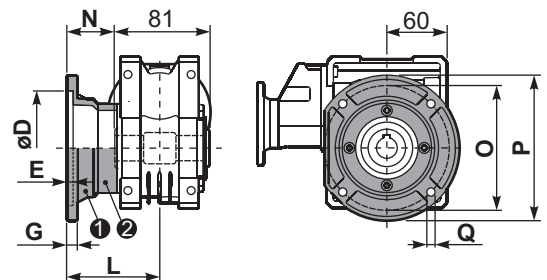

type S	øD	E	G	L	N	O	P	Q	kit code
F1	110 H8	5	10	89	69.5	130	160	9.5	KSQ50.9.012
F2	95 H8	5	14.5	72	31.5	115	140	11	KSQ50.9.013

**PP5QFB...** Feet  
Piedini

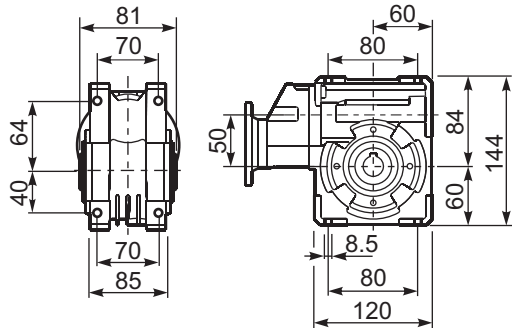

**PP5QBR...** Reaction arm  
Braccio di reazione

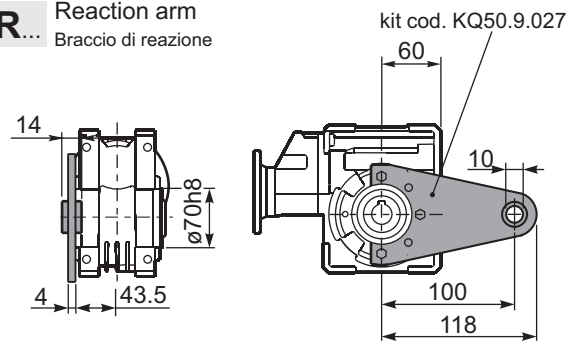

**RP5QFB...** Input shaft  
Albero in entrata

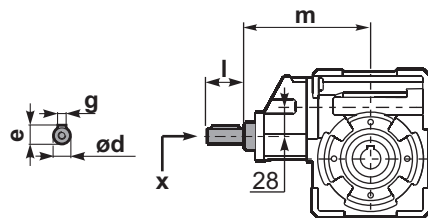

	ød	e	g	l	m	x	
type B	14 h6	16	5	25	140.5	M5x13	C35.5.061
type S	-	-	-	-	-	-	

**PP5Q.....S...** Single Shaft  
Albero lento semplice

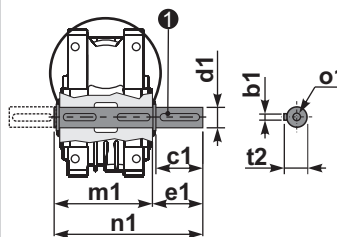

**PP5Q.....D...** Double Shaft  
Albero lento bisp.

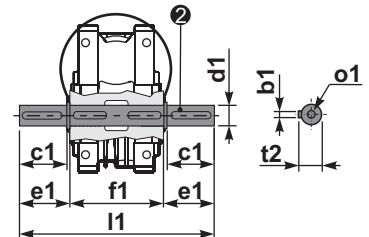

① kit cod. K050.5.028 type B  
kit cod. KS050.5.030 type S

② kit cod. K050.5.029 type B  
kit cod. KS050.5.031 type S

	b1	c1	d1	e1	f1	l1	m1	n1	t2	o1
type B	8	52	25 <sup>-0.005</sup> <sub>-0.020</sub>	59.5	81	200	86.5	146	28	M8x20
type S	8	50	24 <sup>-0.005</sup> <sub>-0.020</sub>	68.8	81	218	86.5	155	27	M8x20